



*Ibanez*

ELECTRIC GUITARS,  
ELECTRIC BASSES,  
AMPLIFIERS, EFFECTS  
& ACCESSORIES  
2009

Ibanez has a rich heritage of producing high quality instruments that spans decades. Though the history is far reaching, the Ibanez impact on the music industry has not been solely due to the amount of time it has existed as a company. Each Ibanez instrument has demonstrated its value time and time again through its exceptional functionality and sheer versatility. The instruments have evolved to meet the new demands of musicians and push the limits of what is possible. For 2009, the envelope is being pushed again. The new RG3570Z and RG3550MZ Prestige models feature the 80's edition of the Super Wizard necks with modern strength. The models with Maple

fingerboards provide a more sensitive touch to the way each instrument responds. There are different graphics that have been applied to various models to blur the lines between guitars as instruments or fashion statements. The new Darkstone series takes on the ambitious task of applying modern functionality and building techniques to a classic sense of design.

## Table of Contents

RG Prestige	4-7		
RG Tremolo	8-10		
GRG/GRX	11		
RGa	12		
RG Fixed	13		
X series	14-15	GSA	29
ART	16-18	SZR	30
ARX	17-18	AR	31
GART/GAX	19	JTK	32
DN	20	GRGM	32
FR Prestige	21	Signature Guitars	34-41
S Prestige	22-23	ARTCORE Custom	42-43
S	24-25	AF	44-45
SV Prestige	26	AK	45
SA	28-29	AFS	46
		AG	47
		AS	48
		ACS	49
		AM	49
		SR Prestige	52-54
		SR	55-59
		GSR	60-61
		SRX	62-63

This year also marks the return of all SR Prestige models to their "Made in Japan" roots. These instruments represent the top of the line in components and craftsmanship. The SRX has been refined to be even more of an extreme bass, while the ATK has been modified to provide more of a simple and raw punk bass sound. They represent two ends of the spectrum, united by the Ibanez trademark of performance and play-

ability. Ibanez has also long been an innovator in the realm of hardware and electronics for electric guitars and basses. The legendary Edge tremolo, Gibraltar bridge, and mono-rail bridges have redefined the way an electric instrument feels and responds. This catalog represents the latest advances in Ibanez hardware and electronics, promising even greater tuning stability and massive sounds. Never one to be complacent, Ibanez has taken its rich heritage a step further this year. The best of the past has been combined with the best of the present to produce instruments that will meet the demands of the future. We are proud to produce instruments that musicians everywhere can be proud to own.

BTB	64-66	Jumpstart	76-77	TONE-LOK	88-89
ICB	67	Sound Wave	80-81	TS808 & 9series	90
ARTB	67	Tone Blaster X	82-83	Tuners	91
Signature Basses	68-70	MIMX	84	Cables	92
EDB	71	Thermion	85	Picks	93
ATK	72-73	Troubadour	86-87	Bags & Cases	94-95
JTKB	74	JEMINI	88	Straps/Pick Holder	96
ARTCORE	74	TUBE KING	88	Pickup Characters & Neck Dimensions	97

# RG *Prestige*

The Ibanez Wizard neck is legendary for its super fast playability, especially with shred players. For 2009, the RG3000 series features the Super Wizard neck, a faithful reproduction of the original Wizard neck from 1987. All RG Prestige models are "Made in Japan" by the finest Ibanez craftsmen and from top of the line components.



## Edge-Zero Tremolo

The Edge-Zero has a sharp knife-edge for extremely accurate tremolo playing. This tremolo also uses Ibanez innovations to keep string action constant and the bridge surface smooth. The specially designed arm socket prevents unnecessary wobble from the arm while providing full control over the arm's torque.

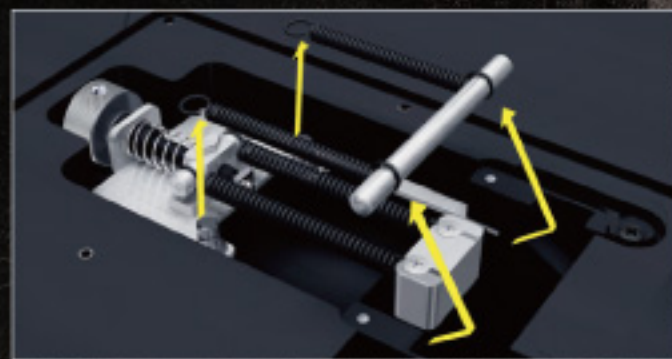
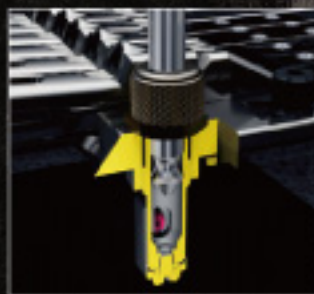

## ZPS3 Zero Point System

The ZPS3 is the next stage of zero point systems. Made of lightweight Duralumin, the addition of two outer springs makes the guitar easier to tune and provides

much greater tuning stability. In fact, the other strings will stay in tune even if you break a string. If you prefer a full floating tremolo setup, simply remove the stop bar.



### RG3570Z CA

- 5pc Super Wizard Maple / Walnut neck
- Basswood body
- Jumbo frets
- Edge-Zero bridge w/ZPS3
- DiMarzio® Air Norton™ (H) neck pu
- DiMarzio® True Velvet™ (S) mid pu
- DiMarzio® Tone Zone® (H) bridge pu
- Hardware color: CK
- Scale: 648mm/25.5"
- Colors: CA (Candy Apple)  
LB (Lazer Blue)



## Super Wizard Neck

The RG3570Z and RG3550MZ Prestige models feature the Super Wizard neck, an exact reproduction of the original RG550 Wizard neck from 1987 (17mm/19mm at 1st/12th fret). The strength and stability of this legendary neck has been improved due to the new 5-ply construction.



## DiMarzio® Pickups

The RG3570Z and RG3550MZ also feature the DiMarzio® Tone Zone® in the bridge position, True Velvet™ in the middle position, and the Air Norton™ in the neck position. With colored bobbins, these pickups add the flair of the 80s music scene to these modern designs.



### RG3570Z LB

- 5pc Super Wizard Maple / Walnut neck
- Basswood body
- Jumbo frets
- Edge-Zero bridge w/ZPS3
- DiMarzio® Air Norton™ (H) neck pu
- DiMarzio® True Velvet™ (S) mid pu
- DiMarzio® Tone Zone® (H) bridge pu
- Hardware color: CK
- Scale: 648mm/25.5"
- Colors: CA (Candy Apple)  
LB (Lazer Blue)

### RG3550MZ GK

- 5pc Super Wizard Maple / Walnut neck
- Basswood body
- Jumbo frets
- Edge-Zero bridge w/ZPS3
- DiMarzio® Air Norton™ (H) neck pu
- DiMarzio® True Velvet™ (S) mid pu
- DiMarzio® Tone Zone® (H) bridge pu
- Hardware color: CK
- Scale: 648mm/25.5"
- Colors: GK (Galaxy Black)  
GW (Galaxy White)

### RG3550MZ GW

- 5pc Super Wizard Maple / Walnut neck
- Basswood body
- Jumbo frets
- Edge-Zero bridge w/ZPS3
- DiMarzio® Air Norton™ (H) neck pu
- DiMarzio® True Velvet™ (S) mid pu
- DiMarzio® Tone Zone® (H) bridge pu
- Hardware color: CK
- Scale: 648mm/25.5"
- Colors: GK (Galaxy Black)  
GW (Galaxy White)



**RG1570  
CA**

- Spc Wizard Maple /Walnut neck *2-Step*
- Basswood body
- Jumbo frets
- Edge Pro bridge
- V7 (H) neck pu
- S1 (S) mid pu
- V8 (H) bridge pu
- Hardware color: CK
- Scale: 648mm/25.5"
- Colors: BK (Black)  
CA (Candy Apple)



**RG1570  
BK**

- Spc Wizard Maple /Walnut neck *2-Step*
- Basswood body
- Jumbo frets
- Edge Pro bridge
- V7 (H) neck pu
- S1 (S) mid pu
- V8 (H) bridge pu
- Hardware color: CK
- Scale: 648mm/25.5"
- Colors: BK (Black)  
CA (Candy Apple)



**Edge Pro Tremolo**

The Edge-Pro makes use of several innovations in tremolo design. A Sound Metal Chip is present on each saddle to increase sustain at the most critical point of contact, the intonation point. The string holder blocks are part of the bridge, so you don't have to worry about them falling out when changing strings. You can also install new strings on the Edge-Pro without having to cut the ball end off.

**RG**  
*Prestige*

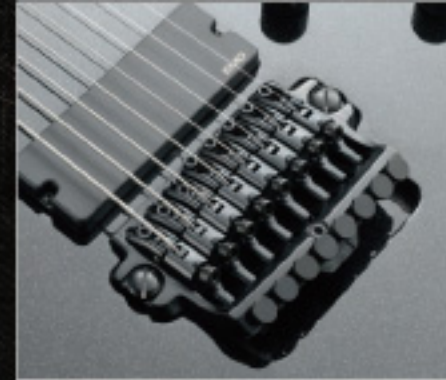

**FX EDGE III-8 Bridge**

Ibanez FX EDGE III-8 double-locking fixed bridge was made specifically to handle and augment the awesome extended range of the RG2228GK 8-string.



**EMG® 808 Pickups**

The U.S.A.-made EMG® 808 active pickups—the first ever full-production 8-string pickups.



**RG2228  
GK**

- Spc Ultra-8 Maple /Wenge neck *2-Step*
- Basswood body
- Jumbo frets
- FX EDGE III-8 bridge
- EMG® 808 neck pu
- EMG® 808 bridge pu
- Hardware color: BK
- Scale: 685.8mm/27"
- Factory Tuning: 1D#, 2A#, 3F#, 4C#, 5G#, 6D#, 7A#, 8F#
- String Gauge: .009/.011/.016/.024/.032/.042/.054/.065
- Color: GK (Galaxy Black)



**RG1527  
RB**

- Spc Wizard Maple /Wenge neck *2-Step*
- Basswood body
- Jumbo frets
- Edge Pro 7 bridge
- V77 (H) neck pu
- V87 (H) bridge pu
- Hardware color: CK
- Scale: 648mm/25.5"
- Color: RB (Royal Blue)



**RGT320Z  
RS**

- Spc Wizard Maple /Wenge neck-thru *2-Step*
- AAA Quilted Maple top
- Mahogany wing body
- Jumbo frets
- Edge-Zero bridge w/ZPS3
- DWMarzio® IBZ-N (H) neck pu
- DWMarzio® IBZ-B (H) bridge pu
- Hardware color: CK
- Scale: 648mm/25.5"
- Color: RS (Red Spinel)

# RG tremolo

**R**G Tremolo models stand up to the most abusive whammy bar users around, while still maintaining perfect tuning stability. Lightning fast fretboard work is no problem with the Wizard neck, flat fingerboard and jumbo frets.

## RGT42DXFM TGB

- 5pc Wizard II Maple
- Walnut neck-thru
- Flamed Maple top
- Mahogany body
- Jumbo frets
- Edge III bridge
- INF1 (H) neck pu
- INF2 (H) bridge pu
- Hardware color: PC
- Scale: 648mm/25.5"
- Color: TGB (Transparent Gray Burst)



## RGT42MDX WH

- 5pc Wizard II Maple
- Walnut neck-thru
- Mahogany body
- Jumbo frets
- Edge III bridge
- INF1 (H) neck pu
- INF2 (H) bridge pu
- Hardware color: PC
- Scale: 648mm/25.5"
- Color: WH (White)



## RG420CM NBF

- 3pc Wizard II Maple neck
- Cinnamon top
- Mahogany body
- Jumbo frets
- Edge III bridge
- INF1 (H) neck pu
- INF2 (H) bridge pu
- Hardware color: CK
- Scale: 648mm/25.5"
- Color: NBF (Natural Brown Burst Flat)



## RG420EG BAM

- 3pc Wizard II Maple neck
- Basswood body
- Jumbo frets
- Edge III bridge
- V7 (H) neck pu
- V8 (H) bridge pu
- Hardware color: BK
- Scale: 648mm/25.5"
- Color: BAM (Bio Armor)



## RG320PG P3

- 3pc Wizard II Maple neck
- Basswood body
- Jumbo frets
- Edge III bridge
- INF3 (H) neck pu
- INF4 (H) bridge pu
- Hardware color: BK
- Scale: 648mm/25.5"
- Color: P3 (Bloody Skull)



# RG tremolo



## Edge III Tremolo

Ibanez has long been admired for the Edge tremolo, and the Edge III embodies all of the classic function of the original Edge with some modern updates. It features lower profile fine-tuners, much like the Lo-PRO Edge. There are also two screws in the arm pocket for easy adjustment of the arm height and torque.



### RG370DXL BK

- 3pc Wizard II Maple neck
- Basswood body
- Jumbo frets
- Edge III bridge
- INF3 (H) neck pu
- INF53 (S) mid pu
- INF4 (H) bridge pu
- Hardware color: BK
- Scale: 648mm/25.5"
- Color: BK (Black)



### RG350EX BK

- 3pc Wizard II Maple neck
- Basswood body
- Jumbo frets
- Edge III bridge
- INF3 (H) neck pu
- INF53 (S) mid pu
- INF4 (H) bridge pu
- Hardware color: CK
- Scale: 648mm/25.5"
- Color: BK (Black)



### RG350DX WH

- 3pc Wizard II Maple neck
- Basswood body
- Jumbo frets
- Edge III bridge
- INF3 (H) neck pu
- INF53 (S) mid pu
- INF4 (H) bridge pu
- Hardware color: BK
- Scale: 648mm/25.5"
- Color: WH (White)



### RG370DX BK

- 3pc Wizard II Maple neck
- Basswood body
- Jumbo frets
- Edge III bridge
- INF3 (H) neck pu
- INF53 (S) mid pu
- INF4 (H) bridge pu
- Hardware color: BK
- Scale: 648mm/25.5"
- Color: BK (Black)

# A

guitar doesn't have to cost a bundle to sound good. The GIO series was developed for players who want Ibanez quality in a more affordable package.

# GRG GRX

### GRG170DX CA

- 1pc GRG1 Maple neck
- Poplar body
- Medium frets
- Fat 10 bridge
- PSND1 (H) neck pu
- PSND5 (S) mid pu
- PSND2 (H) bridge pu
- Hardware color: CH
- Scale: 648mm/25.5"
- Colors: BKN (Black Night)  
CA (Candy Apple)  
JB (Jewel Blue)



### GRG170DX JB

- 1pc GRG1 Maple neck
- Poplar body
- Medium frets
- Fat 10 bridge
- PSND1 (H) neck pu
- PSND5 (S) mid pu
- PSND2 (H) bridge pu
- Hardware color: CH
- Scale: 648mm/25.5"
- Colors: BKN (Black Night)  
CA (Candy Apple)  
JB (Jewel Blue)



### GRG170DX BKN

- 1pc GRG1 Maple neck
- Poplar body
- Medium frets
- Fat 10 bridge
- PSND1 (H) neck pu
- PSND5 (S) mid pu
- PSND2 (H) bridge pu
- Hardware color: CH
- Scale: 648mm/25.5"
- Colors: BKN (Black Night)  
CA (Candy Apple)  
JB (Jewel Blue)



### GRG170DXL BKN

- 1pc GRG1 Maple neck
- Poplar body
- Medium frets
- Fat 10 bridge
- PSND1 (H) neck pu
- PSND5 (S) mid pu
- PSND2 (H) bridge pu
- Hardware color: CH
- Scale: 648mm/25.5"
- Color: BKN (Black Night)



### GRX20 JB

- 1pc GRX Maple neck
- Basswood body
- Medium frets
- FAT6 bridge
- PSND1 (H) neck pu
- PSND2 (H) bridge pu
- Hardware color: CH
- Scale: 648mm/25.5"
- Colors: BKN (Black Night)  
JB (Jewel Blue)



### GRX20L BKN

- 1pc GRX Maple neck
- Basswood body
- Medium frets
- FAT6 bridge
- PSND1 (H) neck pu
- PSND2 (H) bridge pu
- Hardware color: CH
- Scale: 648mm/25.5"
- Color: BKN (Black Night)





#### RGA Active EQ (for RGA321) Ⓞ

This EQ allows for everything from massive fat low tones to sharp treble tones through the turn of one knob with almost no change in output volume. The tone changes in a smooth and natural curve, so it's easy and quick to find the sound you're looking for.

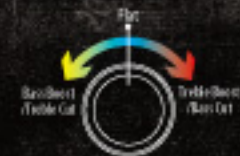

#### LZ4 Pickups (for RGA321) Ⓞ

The LZ4 is an original Ibanez active pickup with a wide dynamic range. It produces powerful and clear humbucker sound with low noise.

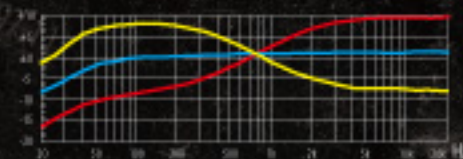

#### Gibraltar Plus Bridge Ⓞ

The Gibraltar Plus builds on the design of the Gibraltar Standard by gently curving the saddles for added comfort.



#### RGA Active EQ (for RGA42) Ⓞ

Specially designed to function with the fat and strong LZ3 pickups, the output is controlled by an active circuit to provide pure tone free of noise.



#### LZ3 Pickups (for RGA42) Ⓞ

The LZ3 is also an original Ibanez active pickup, but with higher output than the LZ4. It produces a fat sound with good clarity perfect for distortion sounds.

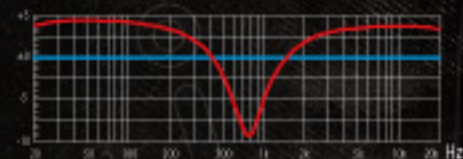

#### Gibraltar Standard Bridge Ⓞ

The Gibraltar is a simple fixed bridge that was designed to adhere firmly to the guitar body and make good transfer of the string vibrations. It is also incredibly smooth for maximum playing comfort.

# RGA

With Gibraltar hard tail bridges and arched top Mahogany body, the RGA is a guitar with great inner strength. This workhorse wraps abundant resonance and natural sustain in a simple and elegant guitar design.



#### RGA321 SPB

- 5pc Wizard Maple / Walnut neck
- Flamed Maple top
- Mahogany body
- Jumbo frets
- Gibraltar Plus bridge
- LZ4-N (H) neck pu
- LZ4-B (H) bridge pu
- Hardware color: CK
- Scale: 648mm/25.5"
- Color: SPB (Sapphire Blue)

#### RGA42 BK

- 3pc Wizard II Maple neck
- Mahogany body
- Jumbo frets
- Gibraltar Standard bridge
- LZ3-N (H) neck pu
- LZ3-B (H) bridge pu
- Hardware color: CK
- Scale: 648mm/25.5"
- Color: BK (Black)

#### RGA42FM TGB

- 3pc Wizard II Maple neck
- Flamed Maple top
- Mahogany body
- Jumbo frets
- Gibraltar Standard bridge
- LZ3-N (H) neck pu
- LZ3-B (H) bridge pu
- Hardware color: CK
- Scale: 648mm/25.5"
- Color: TGB (Transparent Gray Burst)

Sometimes keeping things simple is the way to go. The RG Fixed series is for players who prefer a straightforward fixed bridge setup.

# RG Fixed



#### RGR421EXFM TLB

- 3pc Wizard II Maple neck
- Flamed Maple top
- Mahogany body
- Jumbo frets
- Fixed bridge
- V7 (H) neck pu
- V8 (H) bridge pu
- Hardware color: CK
- Scale: 648mm/25.5"
- Color: TLB (Transparent Lavender Burst)

#### RG321MH MOL

- 3pc Wizard II Maple neck
- Mahogany body
- Jumbo frets
- Fixed bridge
- INF3 (H) neck pu
- INF4 (H) bridge pu
- Hardware color: CK
- Scale: 648mm/25.5"
- Color: MOL (Mahogany Oil)

#### RGT6EXFX BK

- 5pc Wizard II Maple / Walnut neck-thru
- Mahogany wing body
- Jumbo frets
- Fixed bridge
- EMG® 85 (H) neck pu
- EMG® 81 (H) bridge pu
- Hardware color: BK
- Scale: 648mm/25.5"
- Color: BK (Black)

#### RG7321 BK

- 5pc Wizard II-7 Maple / Walnut neck
- Basswood body
- Jumbo frets
- 7-string Fixed bridge
- AH7-1 (H) neck pu
- AH7-2 (H) bridge pu
- Hardware color: BK
- Scale: 648mm/25.5"
- Color: BK (Black)



### 27 fret/DiMarzio® Air Norton 5™ Neck Pickup

The XPT700XH joins its shred-friendly features, such as 27 frets for full access to the upper frets, with the same exact placement of the neck pickup used on the other Xiphos guitars using the Air Norton 5™.

### XPT700XH GSF

- Spc Wizard II Maple/Walnut neck-thru
- Mahogany wing body
- Jumbo fret
- Edge III bridge
- DiMarzio® Air Norton 5™ 00 neck pu
- DiMarzio® D Activator™ (H) bridge pu
- Hardware color: BK
- Scale: 648mm/25.5"
- Color: GSF (Green Shadow Flat)

### XPT700 RCM

- Spc Wizard II Maple/Walnut neck-thru
- Mahogany wing body
- Jumbo fret
- Edge III bridge
- DiMarzio® D Activator™ (H) neck pu
- DiMarzio® D Activator™ (H) bridge pu
- Hardware color: CK
- Scale: 648mm/25.5"
- Color: RCM (Red Chameleon)

### XPT707FX GCM

- Spc Wizard II Maple/Walnut neck-thru
- Mahogany wing body
- Jumbo fret
- Gibraltar Custom-7 bridge
- DiMarzio® D Activator 7™ (H) neck pu
- DiMarzio® D Activator 7™ (H) bridge pu
- Hardware color: CK
- Scale: 648mm/25.5"
- Color: GCM (Gray Chameleon)

### Gibraltar Custom 7 Bridge

The Gibraltar Custom 7 is a massive milled brass, 7 string version of Gibraltar Custom bridge.



# XIPHOS

# Xseries

With the advent of the X series, Ibanez reintroduced non-traditional guitar shapes back into the mix. These off the wall shapes stand out in a crowd, but they are also excellent examples of form meeting function. The XPT

was developed for the extreme shred player with its fast neck and tremolo system. The ICT is great for hard rock, where thick tones are literally beaten out of the guitar. The DTT is a high gain animal, cutting through the most dense forests of fuzz and distortion.



### DiMarzio® D Activator-X™ Pickups

DiMarzio® D Activator-X pickups combine extreme power and clarity through the use of specially tuned coils.



### Neck-Thru Construction

Neck-thru construction on the X-series provides massive sustain and playing comfort.

# ICT700 BK

- Spc Wizard II Maple/Walnut neck-thru
- Mahogany wing body
- Jumbo fret
- Gibraltar Custom bridge
- DiMarzio® D Activator™ (H) neck pu
- DiMarzio® D Activator™ (H) bridge pu
- Hardware color: BK
- Scale: 648mm/25.5"
- Color: BK (Black)

### DTT700 MGS

- Spc Wizard II Maple/Walnut neck-thru
- Mahogany wing body
- Jumbo fret
- Gibraltar Custom bridge
- DiMarzio® D Activator-X™ (H) neck pu
- DiMarzio® D Activator-X™ (H) bridge pu
- Hardware color: CH
- Scale: 648mm/25.5"
- Color: MGS (Metallic Gray Sunburst)

# DESTROYER



# ART/ARX

Simple and effective, the ART is a classic single cutaway guitar that was built for modern metal. The mahogany body is capable of producing the warm tones of yesterday, while the active low-impedance pickups can handle massive volume levels with very little noise. The ARX takes the tradition of the AR series and brings it into the present. Its slimmer body design and neck are a modern approach to this classic guitar style.



## ART420 HAM

- 1pc ART Mahogany set-in neck
- Spalted Maple top
- Mahogany body
- Medium frets
- Gibraltar II bridge
- Quik Change III tailpiece
- LZ1-N (H) neck pu
- LZ1-B (H) bridge pu
- Hardware color: CK
- Scale: 628mm/24.75"
- Color: HAM (Honey Amber)

## ART300 BNC

- 1pc ART Mahogany set-in neck
- Scalloped-Texture Maple top
- Mahogany body
- Medium frets
- Gibraltar II bridge
- Quik Change III tailpiece
- LZ1-N (H) neck pu
- LZ1-B (H) bridge pu
- Hardware color: CK
- Scale: 628mm/24.75"
- Colors: BKC (Black Calman)
- BNC (Brown Calman)
- GRC (Green Calman)

## ART300 GRC

- 1pc ART Mahogany set-in neck
- Scalloped-Texture Maple top
- Mahogany body
- Medium frets
- Gibraltar II bridge
- Quik Change III tailpiece
- LZ1-N (H) neck pu
- LZ1-B (H) bridge pu
- Hardware color: CK
- Scale: 628mm/24.75"
- Colors: BKC (Black Calman)
- BNC (Brown Calman)
- GRC (Green Calman)

## ART300 BKC

- 1pc ART Mahogany set-in neck
- Scalloped-Texture Maple top
- Mahogany body
- Medium frets
- Gibraltar II bridge
- Quik Change III tailpiece
- LZ1-N (H) neck pu
- LZ1-B (H) bridge pu
- Hardware color: CK
- Scale: 628mm/24.75"
- Colors: BKC (Black Calman)
- BNC (Brown Calman)
- GRC (Green Calman)



## ARX320 TCR

- 1pc ARX Mahogany set-in neck
- Quilted Maple top/Mahogany body
- Medium frets
- Gibraltar III bridge
- Quik Change III tailpiece
- ACH1-S (H) neck pu
- ACH2-S (H) bridge pu
- Hardware color: CH
- Scale: 628mm/24.75"
- Color: TCR (Transparent Cherry)

### Caiman Finish

The ART300 features the Caiman finish, a unique texture created by the scalloped top. This unique top combined with dark stained finishes has the look of reptilian skin.



### LZ1 Pickups

Ibanez original LoZ pickups have made the active pickup sounds accessible for anyone from starters to professionals. Operated by AA batteries, which are more widely available than traditional 9V batteries.



### ART100 TCR

- 1pc ART Mahogany set-in neck
- Maple top/Mahogany body
- Medium frets
- Gibraltar II bridge
- Quik Change III tailpiece
- ACH1-S (H) neck pu
- ACH2-S (H) bridge pu
- Hardware color: CH
- Scale: 628mm/24.75"
- Colors: BK (Black)

TCR (Transparent Cherry)  
WH (White)



### ART100 WH

- 1pc ART Mahogany set-in neck
- Maple top/Mahogany body
- Medium frets
- Gibraltar II bridge
- Quik Change III tailpiece
- ACH1-S (H) neck pu
- ACH2-S (H) bridge pu
- Hardware color: CH
- Scale: 628mm/24.75"
- Colors: BK (Black)

TCR (Transparent Cherry)  
WH (White)



### ART100 BK

- 1pc ART Mahogany set-in neck
- Maple top/Mahogany body
- Medium frets
- Gibraltar II bridge
- Quik Change III tailpiece
- ACH1-S (H) neck pu
- ACH2-S (H) bridge pu
- Hardware color: CH
- Scale: 628mm/24.75"
- Colors: BK (Black)

TCR (Transparent Cherry)  
WH (White)

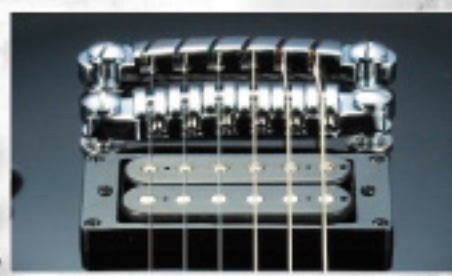

### Gibraltar III Bridge /Quik Change III Tailpiece

With the addition of the Quik Change III tailpiece, string changes are a snap on the Gibraltar III bridge. Its simple rigid design is perfect for harder playing styles.



### ARX140 BK

- 1pc ARX Mahogany set-in neck
- Maple top/Mahogany body
- Medium frets
- Gibraltar III bridge
- Quik Change III tailpiece
- ACH1-S (H) neck pu
- ACH2-S (H) bridge pu
- Hardware color: CH
- Scale: 628mm/24.75"
- Colors: BK (Black)

WH (White)



### ARX140 WH

- 1pc ARX Mahogany set-in neck
- Maple top/Mahogany body
- Medium frets
- Gibraltar III bridge
- Quik Change III tailpiece
- ACH1-S (H) neck pu
- ACH2-S (H) bridge pu
- Hardware color: CH
- Scale: 628mm/24.75"
- Colors: BK (Black)

WH (White)

# ART ARX

# GART

### GART30 GP

- 1pc GART Maple neck
- Basswood body
- Medium frets
- Fixed bridge
- PSND1 (H) neck pu
- PSND2 (H) bridge pu
- Hardware color: CH
- Scale: 628mm/24.75"
- Colors: GP (Gray Pewter)

TR (Transparent Red)

### GART30 TR

- 1pc GART Maple neck
- Basswood body
- Medium frets
- Fixed bridge
- PSND1 (H) neck pu
- PSND2 (H) bridge pu
- Hardware color: CH
- Scale: 628mm/24.75"
- Colors: GP (Gray Pewter)

TR (Transparent Red)



### GAX30 BKN

- 1pc GAX Maple neck
- Basswood body
- Medium frets
- Fixed bridge
- PSND1 (H) neck pu
- PSND2 (H) bridge pu
- Hardware color: CH
- Scale: 628mm/24.75"
- Colors: BKN (Black Night)

JB (Jewel Blue)  
TR (Transparent Red)

### GAX30 JB

- 1pc GAX Maple neck
- Basswood body
- Medium frets
- Fixed bridge
- PSND1 (H) neck pu
- PSND2 (H) bridge pu
- Hardware color: CH
- Scale: 628mm/24.75"
- Colors: BKN (Black Night)

JB (Jewel Blue)  
TR (Transparent Red)

### GAX30 TR

- 1pc GAX Maple neck
- Basswood body
- Medium frets
- Fixed bridge
- PSND1 (H) neck pu
- PSND2 (H) bridge pu
- Hardware color: CH
- Scale: 628mm/24.75"
- Colors: BKN (Black Night)

JB (Jewel Blue)  
TR (Transparent Red)



**A** guitar doesn't have to cost a bundle to sound good. The GIO series was developed for players who want Ibanez quality in a more affordable package. For 2009, Ibanez is proud to introduce the GART, extending the range of options for players at all levels.

# GAX

**I**f simplicity is what you're after, the GAX may be your rock weapon of choice. This mahogany body double cutaway guitar does away with frills, but it keeps the stuff that matters.

# DN

New for 2009, the DN is a solid rock n' roll powerhouse. It features a new design and sound unlike any other Ibanez guitar. The new Tight-Tune Bridge is sturdy and resonant,

and the new tailpiece is equipped with the Ball-End Stopper. The new humbuckers have a quick response with rich harmonics, and the new single coils are fat and powerful when compared with traditional single coils.



### Tight-Tune Bridge/Tailpiece

Solid as a rock, the Tight-Tune bridge and tailpiece were designed to lock down securely and prevent any kind of wobble or movement. Each saddle is locked into the base plate, and the bridge is anchored by stud bolts into the body of the guitar. Furthermore, the studs are also locked onto the base plate so that the maximum vibration from the string is transferred to the body.



### New PPT & HS1 Pickups

The tube pole-piece construction of the new pickups designed for the Ibanez Darkstone offers quick response, sparkling clarity and added harmonics for a humbucker sound. The newly developed humbucker-sized single coil pickups produce loud and crunchy tones that cut through for hard rock and punk styles.



### DN500 BK

- 1 pc DN Sapele set-in neck
- Sapele body
- Medium frets
- Tight-Tune bridge
- Tight-Tune tailpiece
- PPT1-N (H) neck pu
- PPT1-B (H) bridge pu
- Hardware color : CH
- Scale : 628mm/24.75"
- Color : BK (Black)



### DN400 AP

- 1 pc DN Sapele set-in neck
- Sapele body
- Medium frets
- Tight-Tune bridge
- Tight-Tune tailpiece
- HS1-N (S) neck pu
- HS1-B (S) bridge pu
- Hardware color : CH
- Scale : 628mm/24.75"
- Color : AP (Aged Plaster)

# FR *Prestige*

Free Style Rock Gear

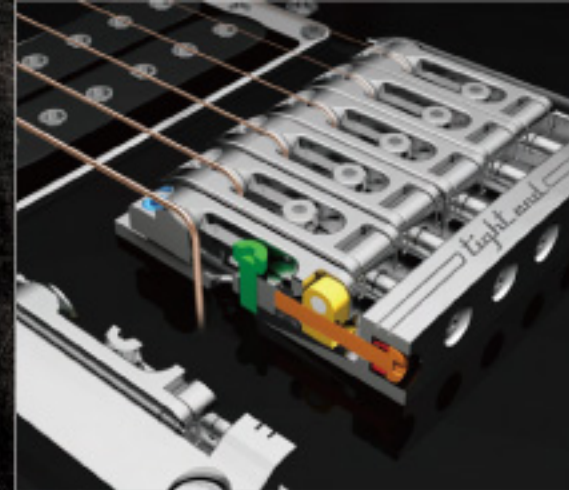

### Tight-End Bridge

The Tight-End bridge integrates every aspect of the bridge design in rigidity and accuracy. Saddles are firmly locked onto the base plate for maximum string vibration, and remain perfectly linear during intonation adjustment for the most accurate set up. The saddle height can be adjusted individually by one screw. Also, the top side of the bridge is smooth finished. So if you play hard, the Tight-End bridge will forgive you and your hands.

The FR first appeared in 2008. With a simple and uncompromising design, the FR is a chameleon when it comes to musical genres. The ash body brings more punch to the midrange tones, while the Tight-End bridge provides maximum string vibration and playing comfort.



### FR2620 DBS

- 3pc Wizard Maple/Walnut neck 22<sup>1/2</sup>
- Ash body
- Jumbo frets
- Tight-End bridge
- CCR1 (H) neck pu
- CCR2 (H) bridge pu
- Hardware color : CH
- Scale : 648mm/25.5"
- Color : DBS (Dark Brown Sunburst)



### CCR Pickups

The Ibanez original CCR pickups don't have the same heat of ceramic magnets, but still have the power to cut through the mix.

### FR1620 BK

- 3pc Wizard Maple/Walnut neck 22<sup>1/2</sup>
- Ash body
- Jumbo frets
- Tight-End bridge
- CCR1 (H) neck pu
- CCR2 (H) bridge pu
- Hardware color : CH
- Scale : 648mm/25.5"
- Color : BK (Black)



# S *Prestige*

## Serious Versatility



### ZR-2 Tremolo

The ZR-2 is a revolutionary tremolo system. It plays incredibly smooth through the use of its ball bearing mechanism. This also keeps the string action constant, even during the most rigorous tremolo use. The top side features a smooth finish for total hand comfort, and the tremolo arm snaps in for quick setup.

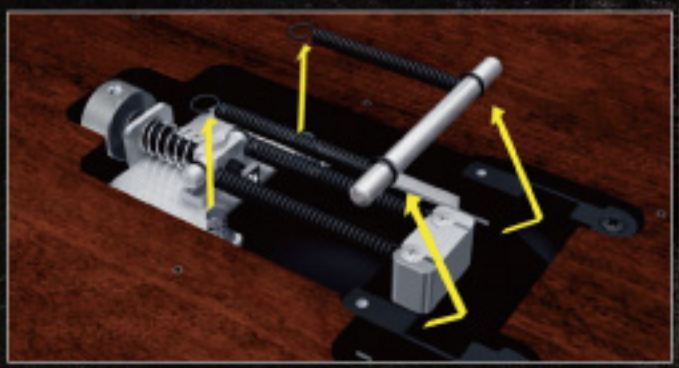

### ZPS3 Zero Point System

The ZPS3 is the next stage of zero point systems. Made of lightweight Duralumin, the addition of two outer springs makes the guitar easier to tune and provides much greater tuning stability. In fact, the other strings will stay in tune even if you break a string. If you prefer a full floating tremolo setup, simply remove the stop bar.

### Sleek Body

The smooth, contoured Mahogany body of the S has long been a favorite for the extreme thrash of heavy metal players to the soft grace of fusion virtuosos.

### S5470F RVK

- Spc Wizard Maple /Walnut neck
- Flamed Maple top
- Mahogany body
- Jumbo frets
- ZR-2 bridge w/ZPS3
- HGD1 (H) neck pu
- ST2 (S) mid pu
- HGD2 (H) bridge pu
- Hardware color : CK
- Scale : 648mm/25.5"
- Color : RVK (Red Viking)



### S5470 RDO

- Spc Wizard Maple /Walnut neck
- Mahogany body
- Jumbo frets
- ZR-2 bridge w/ZPS3
- HGD1 (H) neck pu
- ST2 (S) mid pu
- HGD2 (H) bridge pu
- Hardware color : CK
- Scale : 648mm/25.5"
- Colors : RDO (Red Optimus) TKS (Transparent Black Sunburst)

### Barless Top-Lok

The Barless Top-Lok eliminates the need for a retainer bar to maintain string tension. Through its simple design, it holds the correct angle for the strings without one. The metal-injection molding process means that all the edges remain smooth, so you won't hurt your hands.



### HGD & ST Pickups

The Hot Grinder pickups are specially designed for the S Prestige to output extra volume, yet sharpness is not sacrificed. The new Short Tracer pickup matches perfectly with the hot humbuckers to give versatility on the S guitars and to produce even the most delicate tones.

### S5470 TKS

- Spc Wizard Maple /Walnut neck
- Mahogany body
- Jumbo frets
- ZR-2 bridge w/ZPS3
- HGD1 (H) neck pu
- ST2 (S) mid pu
- HGD2 (H) bridge pu
- Hardware color : CK
- Scale : 648mm/25.5"
- Colors : RDO (Red Optimus) TKS (Transparent Black Sunburst)

The S Prestige series is "Made in Japan" by the finest Ibanez craftsmen and from top of the line components. This beautifully contoured shape, combined with the ZR-2 tremolo system, produces warm resonant tones from a super thin mahogany body.

# S

The Ibanez S series first appeared in 1987. Ever since, it has changed in appearance and function to represent the cutting-edge of Ibanez design. Famous for its lightweight carved mahogany body, the S can

take a beating while still providing the resonance of guitars twice its size. The S series also comes equipped with the ZR tremolo system, a smooth ball bearing tremolo that makes every subtle nuance of whammy bar use come alive.



### S670PB NTF

- 3pc Wizard II Maple neck
- Poplar Burl top/Mahogany body
- Jumbo frets
- ZR bridge w/ZPS2
- INF1 (H) neck pu
- INF1 (S) mid pu
- INF2 (H) bridge pu
- Hardware color: CK
- Scale: 648mm/25.5"
- Color: NTF (Natural Flo0)



### S470DXQM RVK

- 3pc Wizard II Maple neck
- Quilted Maple top/Mahogany body
- Jumbo frets
- ZR bridge w/ZPS2
- INF1 (H) neck pu
- INF1 (S) mid pu
- INF2 (H) bridge pu
- Hardware color: CK
- Scale: 648mm/25.5"
- Colors: BBB (Bright Blue Burst)  
RVK (Red Viking)

### S470DXQM BBB

- 3pc Wizard II Maple neck
- Quilted Maple top/Mahogany body
- Jumbo frets
- ZR bridge w/ZPS2
- INF1 (H) neck pu
- INF1 (S) mid pu
- INF2 (H) bridge pu
- Hardware color: CK
- Scale: 648mm/25.5"
- Colors: BBB (Bright Blue Burst)  
RVK (Red Viking)



### S520EX BK

- 3pc Wizard II Maple neck
- Mahogany body
- Jumbo frets
- ZR bridge w/ZPS2
- INF1 (H) neck pu
- INF2 (H) bridge pu
- Hardware color: BK
- Scale: 648mm/25.5"
- Color: BK (Black)



### S320 WK

- 3pc Wizard II Maple neck
- Mahogany body
- Jumbo frets
- ZR bridge w/ZPS2
- INF1 (H) neck pu
- INF2 (H) bridge pu
- Hardware color: CK
- Scale: 648mm/25.5"
- Color: WK (Weathered Black)



### S7320 BK

- 3pc Wizard II-7 Maple neck
- Mahogany body
- Jumbo frets
- ZR-7 bridge w/ZPS2
- AH7-1 (H) neck pu
- AH7-2 (H) bridge pu
- Hardware color: CK
- Scale: 648mm/25.5"
- Color: BK (Black)



#### ZR-7 7-string Tremolo

The innovations of the ZR Tremolo system are not restricted to 6-string players. With the ZR7, the same great frictionless action and reliable tuning stability is available for 7-string players.

# SV *Prestige*

## Serious Versatility

The S series has long been admired for its design, but some players prefer the simplicity of a non-locking tremolo. The SV was created to satisfy the professional player, who wants a more versatile solution. The SynchroniZR non-locking tremolo uses the same smooth ball bearing mechanisms that have made the ZR bridge so popular. The SV also comes equipped with the True-Duo pickup system for superior tonal variety from the single coil and humbucker universe.

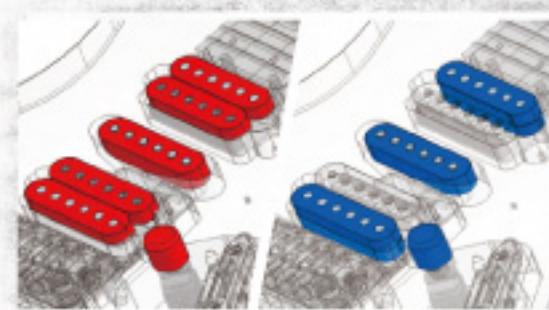

### True-Duo Pickups

The unique formula of the True-Duo system, the combination of Alnico and Ferrite, stacked coils and bar magnet, has answered the conflicting demand for one guitar. In the SSS setting, it outputs glassy and clear single coil sound, not like a coil tap does, while the HSH setting packs a beefy punch, by simply pushing/pulling the volume knob.



### SV5470F NBL

- Spc/Wizard Maple/Walnut neck
- Flamed Maple top
- Mahogany body
- Jumbo frets
- SynchroniZR bridge w/ZPS-FX
- TD82 (H) neck pu
- ST2 (S) mid pu
- TD83 (H) bridge pu
- Hardware color: CK
- Scale: 648mm/25.5"
- Colors: DSB (Dark Sunset Burst) NBL (Natural Blue)

### SV5470F DSB

- Spc/Wizard Maple/Walnut neck
- Flamed Maple top
- Mahogany body
- Jumbo frets
- SynchroniZR bridge w/ZPS-FX
- TD82 (H) neck pu
- ST2 (S) mid pu
- TD83 (H) bridge pu
- Hardware color: CK
- Scale: 648mm/25.5"
- Colors: DSB (Dark Sunset Burst) NBL (Natural Blue)

### SynchroniZR Tremolo

The SynchroniZR provides all the innovations of the ZR tremolo in a non-locking design. The one-piece saddle construction minimizes unnecessary wobble and loss of string vibration, and the ultra-light Duralumin tremolo arm keeps the bridge stable while playing. The same intonation and adjustment features of the ZR-2 make this a top-notch choice for any kind of player.



### ZPS-FX System

The ZPS-FX is the simplified alternative to the ZPS3 system. This spring system allows switching from floating to non-floating tremolos with the turn of a knob on the back. Coupled with the SynchroniZR, the ZPS-FX offers total sonic control and the pinnacle of tuning stability.

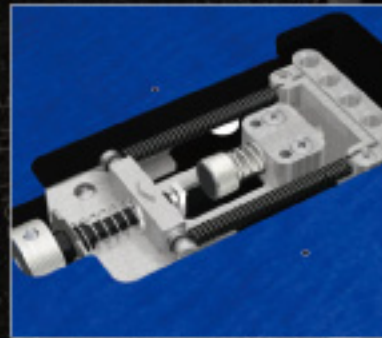

## Ibanez Artists



# SA



## Set-in Neck Construction

SAS set-in neck features strong 3pc construction and special neck finish for extraordinary comfort and playability.



### SAS32EXFM AV

- 3pc SAS Maple set-in neck
- Flamed Maple top/Mahogany body
- Medium frets
- SAT Pro II bridge
- True Duo Buckler (H) neck pu
- True Duo Buckler (H) bridge pu
- Hardware color: CK
- Scale: 648mm/25.5"
- Color: AV (Antique Violin)



### SAS32EX BK

- 3pc SAS Maple set-in neck
- Mahogany body
- Medium frets
- SAT Pro II bridge
- True Duo Buckler (H) neck pu
- True Duo Buckler (H) bridge pu
- Hardware color: CK
- Scale: 648mm/25.5"
- Colors: BK (Black)
- WH (White)



### SAS32EX WH

- 3pc SAS Maple set-in neck
- Mahogany body
- Medium frets
- SAT Pro II bridge
- True Duo Buckler (H) neck pu
- True Duo Buckler (H) bridge pu
- Hardware color: CK
- Scale: 648mm/25.5"
- Colors: BK (Black)
- WH (White)



### SAS36FM TGS

- 3pc SAS Maple set-in neck
- Flamed Maple top /Mahogany body
- Medium frets
- SAT Pro II bridge
- AHS1 (S) neck pu
- AHS2 (S) mid pu
- True Duo Buckler (H) bridge pu
- Hardware color: CH
- Scale: 648mm/25.5"
- Colors: TGS (Transparent Gray Sunburst)
- TRS (Transparent Red Sunburst)

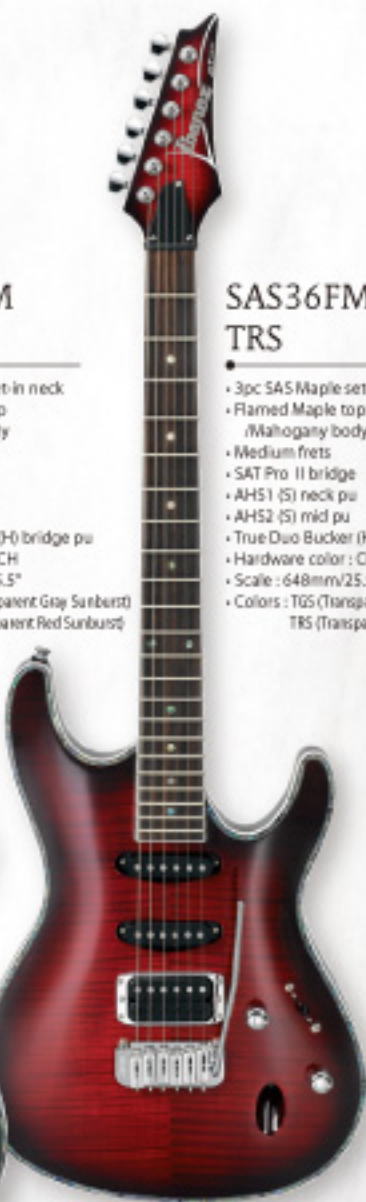

### SAS36FM TRS

- 3pc SAS Maple set-in neck
- Flamed Maple top /Mahogany body
- Medium frets
- SAT Pro II bridge
- AHS1 (S) neck pu
- AHS2 (S) mid pu
- True Duo Buckler (H) bridge pu
- Hardware color: CH
- Scale: 648mm/25.5"
- Colors: TGS (Transparent Gray Sunburst)
- TRS (Transparent Red Sunburst)

**Y**ou want versatility? The SA adapts to any genre of music for clean rhythm, crunchy blues or even hard driving riffs and solos. It also offers a variety of looks such as metal-like

solid colors or traditional wooden finishes. The SA also makes use of the same True-Duo pickup system available on the SV models and the abundant resonance of the SAT-Pro II tremolo.



## Sat Pro II Tremolo

The Sat Pro II eliminates unnecessary resonance around the saddles by firmly securing them to the bridge plate. This keeps the saddles very stable even during frequent tremolo use.

### SA260FM AMB

- 3pc SA Maple neck
- Flamed Maple top/Mahogany body
- Medium frets
- SAT Pro II bridge
- AHS1 (S) neck pu
- AHS2 (S) mid pu
- True Duo Buckler (H) bridge pu
- Hardware color: CH
- Scale: 648mm/25.5"
- Colors: AMB (Amber Burst)
- BBS (Blackberry Sunburst)



### SA260FM BBS

- 3pc SA Maple neck
- Flamed Maple top/Mahogany body
- Medium frets
- SAT Pro II bridge
- AHS1 (S) neck pu
- AHS2 (S) mid pu
- True Duo Buckler (H) bridge pu
- Hardware color: CH
- Scale: 648mm/25.5"
- Colors: AMB (Amber Burst)
- BBS (Blackberry Sunburst)



### SA120 BK

- 3pc SA Maple neck
- Mahogany body
- Medium frets
- SAT Pro II bridge
- AHS (H) neck pu
- AHS (H) bridge pu
- Hardware color: CH
- Scale: 648mm/25.5"
- Colors: BK (Black)
- CN (Charcoal Brown)



### SA120 CN

- 3pc SA Maple neck
- Mahogany body
- Medium frets
- SAT Pro II bridge
- AHS (H) neck pu
- AHS (H) bridge pu
- Hardware color: CH
- Scale: 648mm/25.5"
- Colors: BK (Black)
- CN (Charcoal Brown)



### GSA60 JB

- 1pc GSA Maple neck
- Agathis body
- Medium frets
- SAT 10 bridge
- PSND5 (S) neck pu
- PSND5 (S) mid pu
- PSND2 (H) bridge pu
- Hardware color: CH
- Scale: 648mm/25.5"
- Colors: BKN (Black Night)
- JB (Jewel Blue)





### 60mm thickness Body

SZR models' 60mm thick mahogany body with maple top.



### Neo Z Pickups

The SZR's massive tone is also supported by the new original Neo Z pickups that feature the Neodymium, the strongest magnet for guitar pickups.

# SZR

If thin is in, then the SZR is a true rebel. This guitar was built tough with a thick mahogany body for the warm, dark tones of a traditional solid body. The set-in neck makes every note sing with sustain and provides improved comfort when you grab the high notes.

### SZR720 TGB

- 1pc SZR Mahogany set-in neck
- Quilted Maple top on Maple
- Mahogany body
- Medium frets
- Gibraltar II bridge
- ND2-N (H) neck pu
- ND2-B (H) bridge pu
- Hardware color: GD
- Scale: 628mm/24.75"
- Colors: BB (Blackberry)
- TGB (Transparent Gray Burst)

### SZR720 BB

- 1pc SZR Mahogany set-in neck
- Quilted Maple top on Maple
- Mahogany body
- Medium frets
- Gibraltar II bridge
- ND2-N (H) neck pu
- ND2-B (H) bridge pu
- Hardware color: GD
- Scale: 628mm/24.75"
- Colors: BB (Blackberry)
- TGB (Transparent Gray Burst)

### SZR520 DHS

- 1pc SZR Mahogany set-in neck
- Flamed Maple top on Maple
- Mahogany body
- Medium frets
- Gibraltar II bridge
- ND2-N (H) neck pu
- ND2-B (H) bridge pu
- Hardware color: CH
- Scale: 628mm/24.75"
- Colors: DHS (Dark Honey Sunburst)
- LBB (Light Blue Burst)
- TEB (Transparent Emerald Burst)

### SZR520 LBB

- 1pc SZR Mahogany set-in neck
- Flamed Maple top on Maple
- Mahogany body
- Medium frets
- Gibraltar II bridge
- ND2-N (H) neck pu
- ND2-B (H) bridge pu
- Hardware color: CH
- Scale: 628mm/24.75"
- Colors: DHS (Dark Honey Sunburst)
- LBB (Light Blue Burst)
- TEB (Transparent Emerald Burst)

### SZR520 TEB

- 1pc SZR Mahogany set-in neck
- Flamed Maple top on Maple
- Mahogany body
- Medium frets
- Gibraltar II bridge
- ND2-N (H) neck pu
- ND2-B (H) bridge pu
- Hardware color: CH
- Scale: 628mm/24.75"
- Colors: DHS (Dark Honey Sunburst)
- LBB (Light Blue Burst)
- TEB (Transparent Emerald Burst)

### AR300RE CS

- 3pc AR Maple set-in neck 28mm
- Flamed Maple top
- Mahogany body
- Medium frets
- Gibraltar bridge w/Sustain Block
- Quik Change saddle
- Super 58 (H) neck pu
- Super 58 (H) bridge pu
- Hardware color: GD
- Scale: 628mm/24.75"
- Color: CS (Cherry Sunburst)



# ARTIST AR Prestige

The AR is a classic among Ibanez guitars. It was one of the first original designs produced by Ibanez and continues to be a sought after guitar. The AR300 continues that legacy with pride.

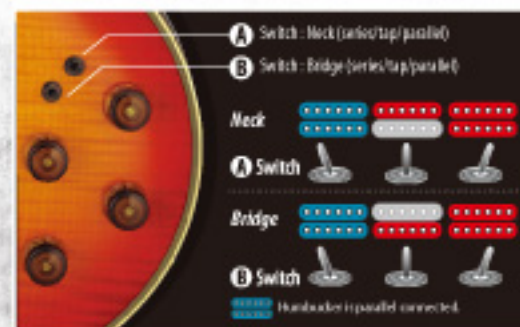

### Tri-Sound Sw

The AR300RE's original Tri-Sound switching system offers the choice of standard humbucking, single coil, or parallel humbucking sounds through the mini switches. Combined with the regular pickup selector, 15 distinct tone settings are available at your fingertips.



### Gibraltar w/Sustain Block

This is a faithful reproduction of the Original Gibraltar bridge.



# JTK Pawnshop Perfection

Some people never forget that first prize guitar that they found at the local pawnshop, and with the JTK they never

have to. The Jet King takes all of the retro styling of a vintage guitar and couples it with solid modern hardware. Ibanez also developed original low noise pickups for the Jet King that reproduce the old school look and sound of soap bar pickups.

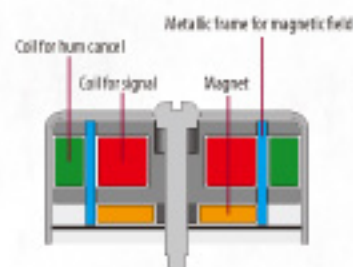

## HFS Pickups

The HFS PU looks like a vintage single coil at first glance, but looks can be deceiving. Underneath, the HFS makes use of a separate coil to cancel any hum or noise generated by the single coil.



## VBX60 Vibrato

Ibanez VBX60 Vintage Vibrato for solid body guitars.



### JTK30H BK

- 3pc Maple JTK neck
- Mahogany body
- Medium frets
- Full Tune II bridge
- HFS1 (S) neck pu
- HFS2 (S) bridge pu
- Hardware color: CH
- Scale: 648mm/25.5"
- Color: BK (Black)

### JTK30 LY

- 3pc Maple JTK neck
- Mahogany body
- Medium frets
- Full Tune II bridge
- HFS1 (S) neck pu
- HFS2 (S) bridge pu
- Hardware color: CH
- Scale: 648mm/25.5"
- Colors: LY (Lime Yellow)
- TQ (Turquoise)

### JTK30 TQ

- 3pc Maple JTK neck
- Mahogany body
- Medium frets
- Full Tune II bridge
- HFS1 (S) neck pu
- HFS2 (S) bridge pu
- Hardware color: CH
- Scale: 648mm/25.5"
- Colors: LY (Lime Yellow)
- TQ (Turquoise)

### JTK40 RD

- 3pc Maple JTK neck
- Mahogany body
- Medium frets
- Full Tune II bridge
- HFS1 (S) neck pu
- HFS2 (S) bridge pu
- Hardware color: CH
- Scale: 648mm/25.5"
- Color: RD (Red)

# MIKRO

Small hands make big sounds with the Ibanez mikros. These compact guitars keep many of the features of their bigger counterparts and even come with a gig bag for hitting the road.



### GRGM21GB BKN

- 1pc GRGM Maple neck
- Poplar body
- Medium frets
- Fixed bridge
- Standard (H) neck pu
- Standard (H) bridge pu
- Hardware color: CH
- Scale: 560mm/22"
- Colors: BRN (Black Night)
- JB (Jewel Blue)
- WH (White)



## Ibanez Artists



## A Shred Machine for the Next Extreme Generation

### EGEN18 TVF

- 3pc EGEN Maple/Walnut neck  Edge
- Flamed Maple top/Mahogany body
- Jumbo frets
- Edge-Zero bridge w/ZPS3
- DiMarzio® HLM (H) neck pu
- DiMarzio® HLM (S) mid pu
- DiMarzio® HLM (H) bridge pu
- Hardware color: GD
- Scale: 648mm/25.5"
- Color: TVF (Transparent Violet Flat)

### HERMAN LI (DRAGONFORCE)



#### Deeper Cut Horn

Modeled using Herman's hand, E-Gen's unique scoop cutaway at the back of the body, allows even easier access to high frets from all angles.



#### Low-Profile Middle Pickup Setting

The Custom DiMarzio® pickup set is designed for a low-profile setting in the middle pickup position, to not get in the way of heavy rhythm down strokes to shredding alternate picking.



### SAM TOTMAN (DRAGONFORCE)

#### STM1 WH

- 3pc Wizard II Maple/Walnut neck-thru
- Mahogany wing body
- Jumbo fret
- Edge II bridge
- DiMarzio® Evolution™ (H) neck pu
- DiMarzio® Evolution™ (H) bridge pu
- Hardware color: CH
- Scale: 648mm/25.5"
- Color: WH (White)



### MICK THOMSON (SLIPKNOT)



#### MTM1 BK

#### MTM1 BR

- 3pc Wizard II Maple/Walnut neck-thru
- Mahogany wing body
- Jumbo frets
- Fixed Lo-Pro Edge bridge
- Seymour Duncan® Blackout (H) neck pu
- Seymour Duncan® Blackout (H) bridge pu
- Hardware color: BK
- Scale: 648mm/25.5"
- Factory tuning: 1C#, 2G#, 3E, 4B, 5F#, 6B
- String gauge: .011/.014/.018/.026/.038/.049
- Colors: BK (Black) BR (Blood Red)

#### MTM2 BK

- 3pc Wizard II Maple/Walnut neck
- Mahogany body
- Jumbo frets
- Fixed Edge II bridge
- V7 (H) neck pu
- V8 (H) bridge pu
- Hardware color: BK
- Scale: 648mm/25.5"
- Factory tuning: 1C#, 2G#, 3E, 4B, 5F#, 6B
- String gauge: .011/.014/.018/.026/.038/.049
- Color: BK (Black)



### MATT BACHAND (SHADOWS FALL)



#### MBM1 BK

#### MBM2 BK

- 3pc Wizard II Maple/Walnut neck  Edge
- Mahogany body
- Jumbo frets
- Gibraltar Standard bridge
- EMG® 60 (H) neck pu
- EMG® 81 (H) bridge pu
- Hardware color: CK
- Scale: 648mm/25.5"
- Factory tuning: 1D, 2A, 3F, 4C, 5G, 6D
- String gauge: .011/.014/.018/.030/.042/.052
- Color: BK (Black)

- 3pc Wizard II Maple neck
- Mahogany body
- Jumbo frets
- Gibraltar Standard bridge
- EMG® 60 (H) neck pu
- EMG® 81 (H) bridge pu
- Hardware color: CK
- Scale: 648mm/25.5"
- Factory tuning: 1D, 2A, 3F, 4C, 5G, 6D
- String gauge: .011/.014/.018/.030/.042/.052
- Color: BK (Black)



### JS1600 PSV

- 1pc JS Maple neck Zedge
- Mahogany body
- W/105 frets
- Fixed bridge
- DiMarzio® Pal Pro® (H) neck pu
- DiMarzio® Fred® (H) bridge pu
- Hardware color : CH
- Scale : 648mm/25.5"
- Color : PSV (Premium Silver)



### JS1200 CA

- 1pc JS Maple neck Zedge
- Basswood body
- W/105 frets
- Edge Pro bridge
- DiMarzio® Pal Joe® (H) neck pu
- DiMarzio® Fred® (H) bridge pu
- Hardware color : CH
- Scale : 648mm/25.5"
- Color : CA (Candy Apple)

JOE SATRIANI



### JS1000 BP

- 1pc JS Maple neck Zedge
- Basswood body
- W/105 frets
- Edge Pro bridge
- DiMarzio® Pal Pro® (H) neck pu
- DiMarzio® Fred® (H) bridge pu
- Hardware color : CK
- Scale : 648mm/25.5"
- Color : BP (Black Pearl)



### JS100 BK

- 1pc JS Maple neck
- Basswood body
- Large frets
- Edge II bridge
- AH1 (H) neck pu
- AH2 (H) bridge pu
- Hardware color : CH
- Scale : 648mm/25.5"
- Color : BK (Black)

### JS100 TR

- 1pc JS Maple neck
- Basswood body
- Large frets
- Edge II bridge
- AH1 (H) neck pu
- AH2 (H) bridge pu
- Hardware color : CH
- Scale : 648mm/25.5"
- Color : BK (Black)
- TR (Transparent Red)



### JEM7EAFX BK

- 5pc JEM Maple /Walnut neck Zedge
- Basswood body
- W/105 frets
- Tight-End bridge
- DiMarzio® Breed™ (H) neck pu
- DiMarzio® Breed™ (S) mid pu
- DiMarzio® Breed™ (H) bridge pu
- Hardware color : CH
- Scale : 648mm/25.5"
- Color : BK (Black)



### JEM7V WH

- 5pc JEM Maple /Walnut neck Zedge
- Alder body
- W/105 frets
- Edge Pro bridge
- DiMarzio® Evolution® (H) neck pu
- DiMarzio® Evolution® (S) mid pu
- DiMarzio® Evolution® (H) bridge pu
- Hardware color : GD
- Scale : 648mm/25.5"
- Color : WH (White)

STEVE VAI

### JEM77V BK

- 5pc JEM Maple /Walnut neck Zedge
- Basswood body
- W/105 frets
- Edge Pro bridge
- DiMarzio® Breed™ (H) neck pu
- DiMarzio® Breed™ (S) mid pu
- DiMarzio® Breed™ (H) bridge pu
- Hardware color : CH
- Scale : 648mm/25.5"
- Color : BK (Black)

### UV777P BK

- 5pc UV Maple /Wenge neck Zedge
- Basswood body
- Jumbo frets
- Edge Pro 7 bridge
- DiMarzio® Blaze 1P® (H) neck pu
- DiMarzio® Blaze 1P® (S) mid pu
- DiMarzio® Blaze 1P® (H) bridge pu
- Hardware color : CH
- Scale : 648mm/25.5"
- Color : BK (Black)





PAUL GILBERT

**PGM401  
TFB**

- 5pc PGM Maple/Walnut neck *Bridge*
- Ash body
- Medium frets
- Fixed bridge
- DiMarzio® Air Classic™ (H) neck pu
- DiMarzio® Air Classic™ (H) bridge pu
- Hardware color: CK
- Scale: 648mm/25.5"
- Color: TFB (Trifade Burst)



NOODLES  
(THE OFFSPRING)



ANDY TIMMONS

**AT100CL  
SB**

- 1pc AT Maple neck *Bridge*
- Alder body
- Jumbo frets
- Wilkinson-Gotoh V5VG bridge
- DiMarzio® Cruiser (S) neck pu
- DiMarzio® Cruiser (S) mid pu
- DiMarzio® AT1 Custom (H) bridge pu
- Hardware color: CH
- Scale: 648mm/25.5"
- Color: SB (Sunburst)

**NDM2  
BK**

- 3pc NDM Maple neck
- Basswood body
- Large frets
- Fixed bridge
- INF1 (H) neck pu
- INF1 (S) mid pu
- INF2 (H) bridge pu
- Hardware color: CH
- Scale: 648mm/25.5"
- Color: BK (Black)



MUNKY  
(KORN)

**APEX2  
GSF**

- 5pc APEX2 Maple/Walnut neck
- Mahogany body
- Jumbo frets
- Tone Pro® 7 bridge
- DiMarzio® Paf 7™ (H) neck pu
- DiMarzio® Paf 7™ (H) bridge pu
- Hardware color: PC
- Scale: 648mm/25.5"
- Factory tuning: 1D, 2A, 3F, 4C, 5G, 6D, 7A
- String gauge: .010/.013/.017/.026/.036/.046/.054
- Color: GSF (Green Shadow Flat)



**APEX1  
BBK**

- 5pc APEX Maple/Wenge neck *Bridge*
- Mahogany body
- Jumbo frets
- Edge Pro 7 bridge w/U-bar
- DiMarzio® Paf 7™ (H) neck pu
- DiMarzio® Paf 7™ (H) bridge pu
- Hardware color: PC
- Scale: 648mm/25.5"
- Factory tuning: 1D, 2A, 3F, 4C, 5G, 6D, 7A
- String gauge: .010/.013/.017/.026/.036/.046/.054
- Color: BBK (Biker's Black)



**ORM1  
WH**

- 3pc ORM Mahogany neck
- Mahogany body
- Medium frets
- Gibraltar III bridge
- ACH-BL (H) bridge pu
- Hardware color: CH
- Scale: 610mm/24.0"
- Color: WH (White)



OMAR RODRIGUEZ LOPEZ  
(THE MARS VOLTA)

## GEORGE BENSON

GB

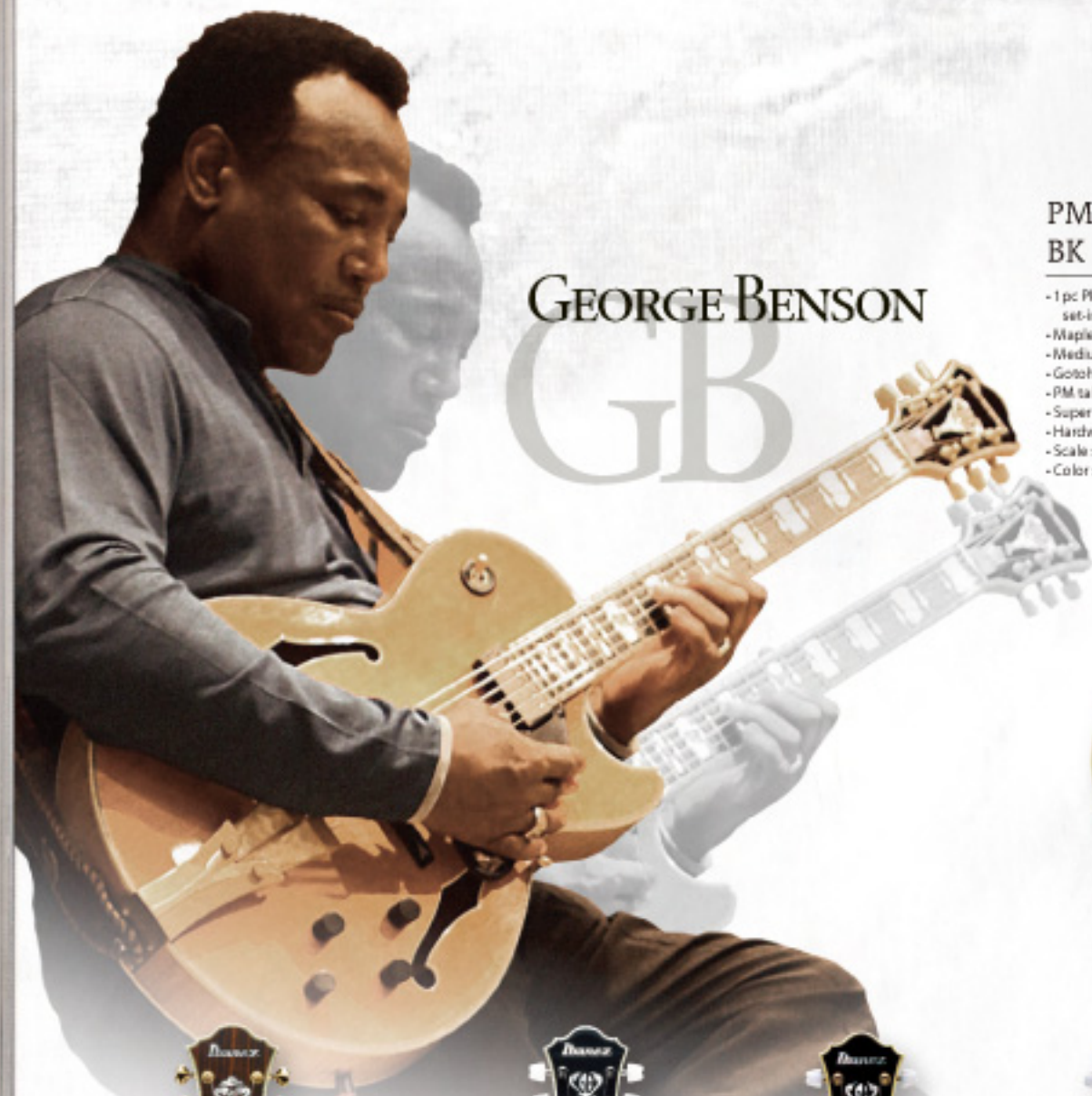

### PM100 BK

- 1 pc PM Mahogany set-in neck
- Maple top/back/sides
- Medium frets
- Gotoh®103B bridge
- PM tailpiece
- Super 58 (H) neck pu
- Hardware color : GD
- Scale : 628mm/24.75"
- Color : BK (Black)



### PM120 BK

- 1 pc PM Mahogany set-in neck
- Maple top/back/sides
- Medium frets
- Gotoh®103B bridge
- PM tailpiece
- Silent 58 (H) neck pu
- Silent 58 (H) bridge pu
- Hardware color : GD
- Scale : 628mm/24.75"
- Colors : BK (Black)  
NT (Natural)



### PM120 NT

- 1 pc PM Mahogany set-in neck
- Maple top/back/sides
- Medium frets
- Gotoh®103B bridge
- PM tailpiece
- Silent 58 (H) neck pu
- Silent 58 (H) bridge pu
- Hardware color : GD
- Scale : 628mm/24.75"
- Colors : BK (Black)  
NT (Natural)



### PM35 NT

- 3pc PM Maple/Walnut set-in neck
- Maple top/back/sides
- Medium frets
- ART-1 bridge
- KT30 tailpiece
- Super 58 Custom (H) neck pu
- Hardware color : GD
- Scale : 628mm/24.75"
- Color : NT (Natural)



## PAT METHENY

PM



## JOHN SCOFIELD

JSM

### JSM100 VT

- 1 pc JSM Mahogany set-in neck
- Flamed maple top
- Maple back/sides
- Jumbo frets
- Gotoh®510BN bridge
- Quik Change II tailpiece
- Super 58 (H) neck pu
- Super 58 (H) bridge pu
- Hardware color : GD
- Scale : 628mm/24.75"
- Color : VT (Vintage Sunburst)

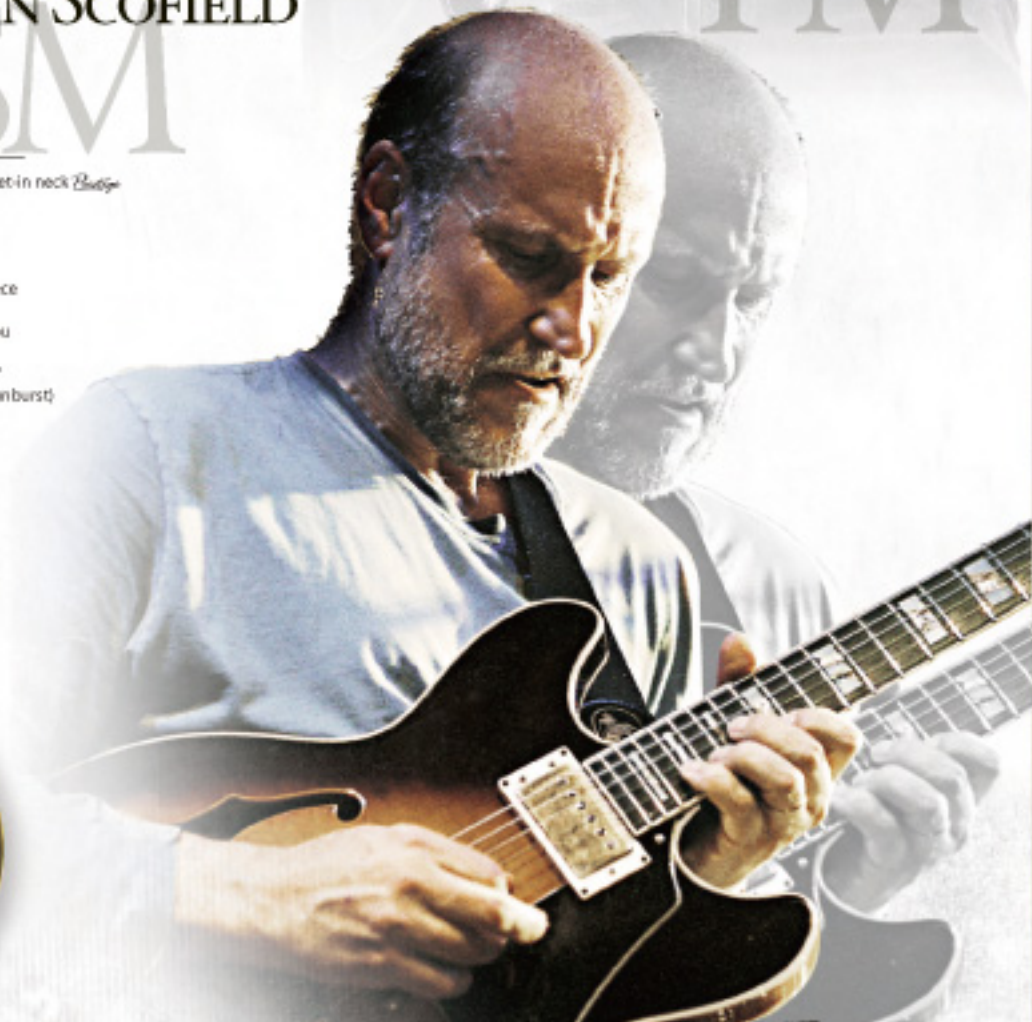

### GB200 BST

- 3pc GB Mahogany/Maple set-in neck
- Spruce top/Maple back/sides
- Medium frets
- Ebony bridge
- GB200 tailpiece
- Super 58 (H) neck pu
- Super 58 (H) bridge pu
- Hardware color : GD
- Scale : 628mm/24.75"
- Color : BST (Brown Sunburst)



### GB15 TR

- 3pc GB15 Maple set-in neck
- Spruce top/Maple back/sides
- Medium frets
- Ebony bridge
- GB15 tailpiece
- GB special (H) neck pu
- Hardware color : CK
- Scale : 628mm/24.75"
- Color : TR (Transparent Red)



### GB10 BS

- 3pc GB Maple set-in neck
- Spruce top/Maple back/sides
- Medium frets
- Ebony bridge
- GB10 tailpiece
- GB special (H) neck pu
- GB special (H) bridge pu
- Hardware color : GD
- Scale : 628mm/24.75"
- Colors : BS (Brown Sunburst)  
NT (Natural)



### GB10 NT

- 3pc GB Maple set-in neck
- Spruce top/Maple back/sides
- Medium frets
- Ebony bridge
- GB10 tailpiece
- GB special (H) neck pu
- GB special (H) bridge pu
- Hardware color : GD
- Scale : 628mm/24.75"
- Colors : BS (Brown Sunburst)  
NT (Natural)



# ARTCORE

The Artcore line represents a step forward in the evolution of affordable hollow body guitars. Since 2002, Ibanez has been producing these exquisite guitars that are at home in a jazz combo

as well as a full-on rock show. Like many other Ibanez models, the Artcores are as versatile as they are beautiful. They come in a variety of sizes and hardware configurations to meet the needs of the one at a price fit for all.



## AS103BM EE

- 5pc Artcore Maple /Walnut set-in neck
- Burl Maple top/back/sides
- Medium frets
- ART-1 bridge
- Quik Change II tailpiece
- Super 58 Custom 0-0 neck pu
- Super 58 Custom 0-0 bridge pu
- Hardware color: GD
- Scale: 628mm/24.75"
- Depth: 43mm at tail
- Color: EE (Exotic Explorer)



## AF105SM EE

- 5pc Artcore Maple /Walnut set-in neck
- Spalted Maple top/back/sides
- Medium frets
- ART-1 bridge
- VT04 Custom tailpiece
- Super 58 Custom (H) neck pu
- Super 58 Custom (H) bridge pu
- Hardware color: GD
- Scale: 628mm/24.75"
- Depth: 70mm at tail
- Color: EE (Exotic Explorer)



### ARTCORE Custom Neck

Artcore-Custom models feature 5pc maple/walnut neck for extra strength and stability.



## AF125 AMB

- 5pc Artcore Maple /Walnut set-in neck
- Quilted Maple top/back/sides
- Medium frets
- ART-1 bridge
- VT04 Custom tailpiece
- Super 58 Custom (H) neck pu
- Super 58 Custom (H) bridge pu
- Hardware color: GD
- Scale: 628mm/24.75"
- Depth: 70mm at tail
- Color: AMB (Amber Burst)



## AF105 NT

- 5pc Artcore Maple /Walnut set-in neck
- Flamed Maple top/back/sides
- Medium frets
- ART-1 bridge
- VT04 Custom tailpiece
- Super 58 Custom (H) neck pu
- Super 58 Custom (H) bridge pu
- Hardware color: GD
- Scale: 628mm/24.75"
- Depth: 70mm at tail
- Color: NT (Natural)





### AF75TDG IV

- 1pc Artcore Mahogany set-in neck
- Maple top/back/sides
- Medium frets
- ART-2 Roller bridge
- VBF70 vibrato
- ACH1 (H) neck pu
- ACH2 (H) bridge pu
- Hardware color : GD
- Scale : 628mm/24.75"
- Depth : 70mm at tail
- Color : IV (Ivory)



VBF70 Vintage Vibrato design licensed by Fred W. Greenich Corporation, Inc. in the U.S.

# AF

**T**he AF is the most traditional of the Artcore series. The traditional full-hollow construction means that there are no sound blocks in the body. Producing rich and complex tones, the AF is the guitar for the purist in all of us.



### AF95 TK

- 3pc Artcore Mahogany /Maple set-in neck
- Flamed Sycamore top/back/sides
- Medium frets
- ART-1 bridge
- VT100DX tailpiece
- ACH1 (H) neck pu
- ACH2 (H) bridge pu
- Hardware color : GD
- Scale : 628mm/24.75"
- Depth : 70mm at tail
- Color : TK (Transparent Black)

### AF75 BS

- 1pc Artcore Mahogany set-in neck
- Maple top/back/sides
- Medium frets
- ART-1 bridge
- VT60 tailpiece
- ACH1 (H) neck pu
- ACH2 (H) bridge pu
- Hardware color : CH
- Scale : 628mm/24.75"
- Depth : 70mm at tail
- Color : BS (Brown Sunburst)

### AK95 DHS

- 3pc Artcore Mahogany /Maple set-in neck
- Spruce top/Sycamore back & sides
- Medium frets
- ART-W wooden bridge
- VT100DX tailpiece
- ACH1 (H) neck pu
- ACH2 (H) bridge pu
- Hardware color : GD
- Scale : 628mm/24.75"
- Depth : 70mm at tail
- Color : DHS (Dark Honey Sunburst)

# AK

**J**azz and blues history is filled with the warm tones of large hollow body guitars. The AK eschews the bright sound of maple tops and metal bridges, replacing them with a spruce top and an all-wood bridge.



#### VBF70 Vintage Vibrato

This old school vibrato adds country and rockabilly nuances to the rich tone of a full-hollow guitar, but the included roller saddles eliminate "old school" tuning problems.

# AFS

**P**ushing traditional concepts one step further, the Ibanez AFS has the same shape and full-hollow body of the AF. For increased comfort and more midrange

punch, the body depth is one inch thinner. An Ibanez Vintage Vibrato is also mounted on the body with roller saddles, eliminating the tuning problems of traditional systems.

# AGT

The AG has a slightly smaller body width than the more traditional AF dimensions. However, the same depth and true full-hollow body construction make for a big standout sound.



## AFS75T NWB

- 1pc Artcore Mahogany set-in neck
- Maple top/back/sides
- Medium frets
- ART-2 Roller bridge
- VBF70 vibrato
- ACH1 (H) neck pu
- ACH2 (H) bridge pu
- Hardware color: CH
- Scale: 628mm/24.75"
- Depth: 43mm at tail
- Colors: NWB (Neo Western Black)  
TRD (Transparent Red)



## AFS75T TRD

- 1pc Artcore Mahogany set-in neck
- Maple top/back/sides
- Medium frets
- ART-2 Roller bridge
- VBF70 vibrato
- ACH1 (H) neck pu
- ACH2 (H) bridge pu
- Hardware color: CH
- Scale: 628mm/24.75"
- Depth: 43mm at tail
- Colors: NWB (Neo Western Black)  
TRD (Transparent Red)



## AG75 BS

- 1pc Artcore Mahogany set-in neck
- Maple top/back/sides
- Medium frets
- ART-1 bridge
- VT60 tailpiece
- ACH1 (H) neck pu
- ACH2 (H) bridge pu
- Hardware color: CH
- Scale: 628mm/24.75"
- Depth: 70mm at tail
- Color: BS (Brown Sunburst)



## AG95 DBS

- 3pc Artcore Mahogany/Maple set-in neck
- Figured Bubinga top/back/sides
- Medium frets
- ART-1 bridge
- VT100DX tailpiece
- ACH1 (H) neck pu
- ACH2 (H) bridge pu
- Hardware color: GD
- Scale: 628mm/24.75"
- Depth: 70mm at tail
- Color: DBS (Dark Brown Sunburst)



The AS is a semi-acoustic guitar built to tackle just about any genre of music you throw at it. The pickups are mounted into a sustain

block for increased sustain and feedback elimination. The Quik Change III bridge makes it easy to change strings without a lot of time involved.

# AS

ARTCORE



## AS93 BLS

- 3pc Artcore Mahogany / Maple set-in neck
- Flamed Sycamore top/back/sides
- Medium frets
- ART-1 bridge
- Quik Change III tailpiece
- ACH1 (H) neck pu
- ACH2 (H) bridge pu
- Hardware color: GD
- Scale: 628mm/24.75"
- Depth: 43mm at tail
- Color: BLS (Blue Sunburst)

## AS73 TCR

- 1pc Artcore Mahogany set-in neck
- Maple top/back/sides
- Medium frets
- ART-1 bridge
- Quik Change III tailpiece
- ACH1 (H) neck pu
- ACH2 (H) bridge pu
- Hardware color: CH
- Scale: 628mm/24.75"
- Depth: 43mm at tail
- Colors: BS (Brown Sunburst) TCR (Transparent Cherry)

## AS73 BS

- 1pc Artcore Mahogany set-in neck
- Maple top/back/sides
- Medium frets
- ART-1 bridge
- Quik Change III tailpiece
- ACH1 (H) neck pu
- ACH2 (H) bridge pu
- Hardware color: CH
- Scale: 628mm/24.75"
- Depth: 43mm at tail
- Colors: BS (Brown Sunburst) TCR (Transparent Cherry)

## AS73B BKF

- 1pc Artcore Mahogany set-in neck
- Maple top/back/sides
- Medium frets
- ART-1 bridge
- Quik Change III tailpiece
- ACH1-S (H) neck pu
- ACH2-S (H) bridge up
- Hardware color: CH
- Scale: 628mm/24.75"
- Depth: 43mm at tail
- Color: BKF (Black Flat)

# AGS

ARTCORE

With a neck joint at the 17th fret for improved upper fret access, the AGS may be an improvement on the AG for many players. Based on the same body design as the AG, the AGS has a thinner body and sound block for feedback reduction and increased sustain.



## 17th Fret to Body Joint

The super-thin AGS83B features a 17-fret body joint and an extra-deep cutaway that makes it the right choice for players who want to spend more time, with ease and comfort, in the upper regions.

## AGS83B ATF

- 3pc Artcore Mahogany / Maple set-in neck
- Flamed Sycamore top/back/sides
- Medium frets
- ART-1 bridge
- Quik Change III tailpiece
- ACH1 (H) neck pu
- ACH2 (H) bridge pu
- Hardware color: CK
- Scale: 628mm/24.75"
- Depth: 43mm at tail
- Color: ATF (Antique Burst Flat)

## AGS83BBG NTF

- 3pc Artcore Mahogany / Maple set-in neck
- Bubinga top/back/sides
- Medium frets
- ART-1 bridge
- Quik Change III tailpiece
- ACH1 (H) neck pu
- ACH2 (H) bridge pu
- Hardware color: CK
- Scale: 628mm/24.75"
- Depth: 43mm at tail
- Color: NTF (Natural Flat)



# AM

The AM was an original Ibanez design in the early '80s. The AM is a natural progression of this design, though smaller in size. This guitar provides infinite playing comfort for smaller players, while holding on to the same light body and abundant sustain that has made the Artcore series so popular.



## AM73B BKF

- 1pc Artcore Mahogany set-in neck
- Maple top/back/sides
- Medium frets
- ART-1 bridge
- Quik Change III tailpiece
- ACH1-S (H) neck pu
- ACH2-S (H) bridge up
- Hardware color: CH
- Scale: 628mm/24.75"
- Depth: 43mm at tail
- Color: BKF (Black Flat)

# Pickup Layout

## H-S-H

RG(HSH), JEM,  
UV, NDA,  
S(HSH), GRG

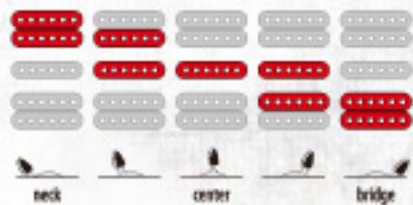

## S-S-H

AT, GSA

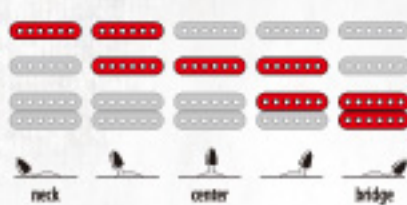

## H-H (3WAY)

JS/DNS00

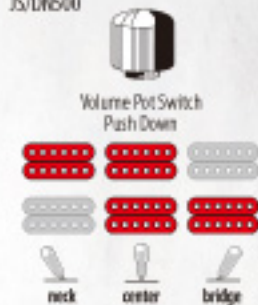

## H-S-H (w/True Duo Blast)

Stacked Single Coil

SV

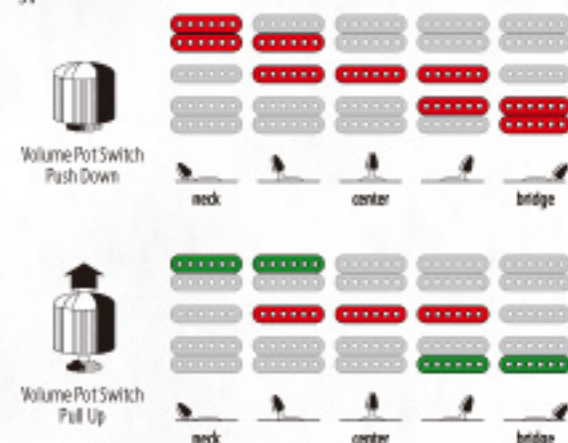

## H-H (w/True Duo Buckler)

Stacked Single Coil

SAS(HH)

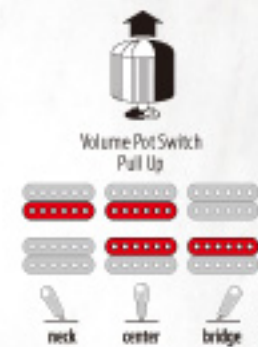
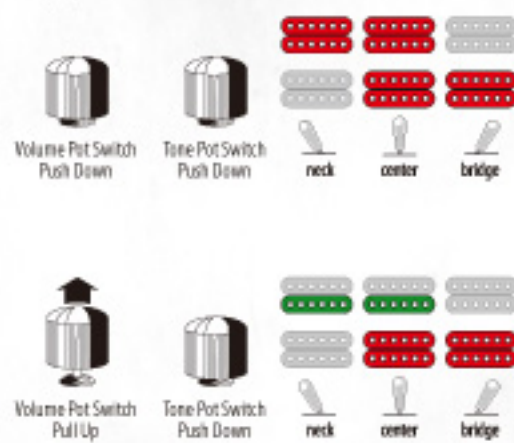

## H-S-H

EGEN18

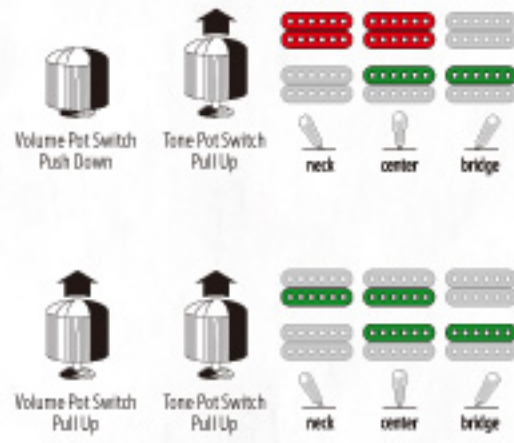
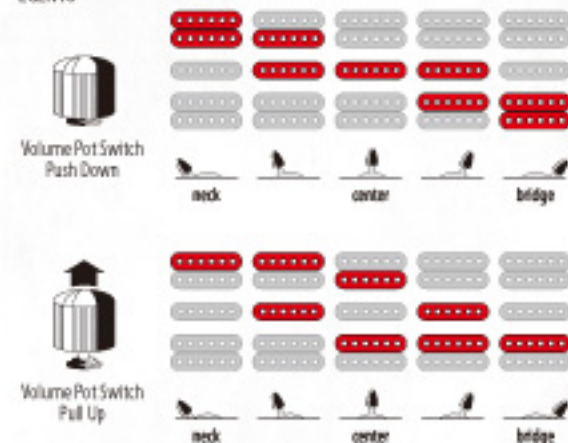

## H-H (3WAY)

SZR

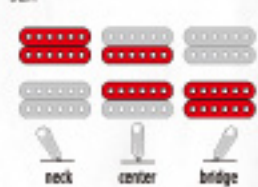

## H-H (3WAY)

AR, ART, ARX, ARTCORE, DTT, GAX,  
GART, APEX, GB, GGM, JSN, JTK40,  
MBM, MTW1, PM120, RG(w/EMG™),  
RGA, XPT(HH), ICT, STM

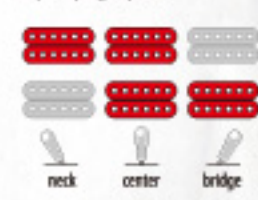

## S-S-H (w/True Duo Buckler)

Stacked Single Coil

SA(SSH)/SAS(SSH)

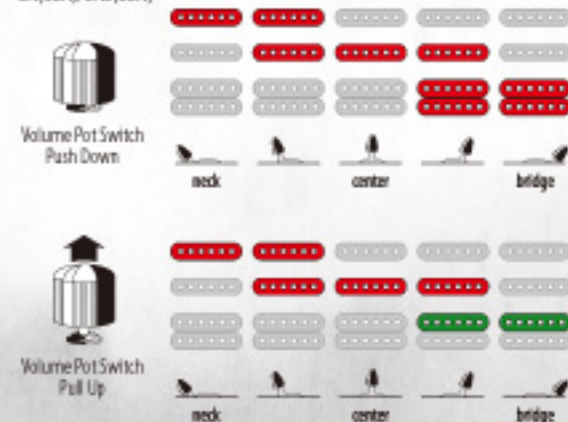

## H-H (5WAY)

Humbucker is parallel connected.

PGM, RG(HH), S(HH), SA(HH), MTM2

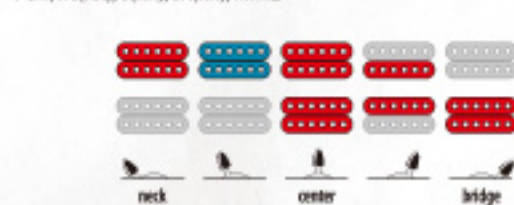

## S-H

XPT700031

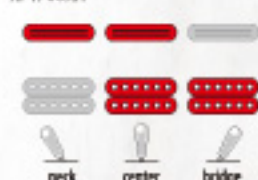

## H-H (5WAY)

FR



## S-S

JTK30, DN400

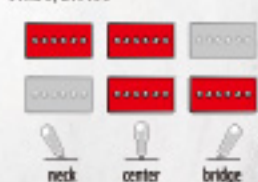

# ELECTRIC BASSES

# SR *Prestige*

## Revolution SR

The SR Prestige is the pinnacle of playing comfort, smart design and Japanese craftsmanship. All SR Prestige models are "Made in Japan" by the finest Ibanez craftsmen and from top of the line components. They feature the Mono-Rail bridge design, with complete string-to-string isolation so that each string vibrates without interference from other strings, the newly developed Power Curve III EQ for vitalizing the low end and midrange tones, and the same classic slim neck that has become an industry standard over the past 20 years.



### Bartolini® US made Pickups

"The US made pickups are hand made at our factory in California exclusively for Ibanez. Ibanez was the first to ask for much deeper tone from the neck pickup while retaining a bright tone for the bridge, unlike traditional designs that used approximately equal pickup tone. The pickups are dual coil designs in several soapbar shapes, some rounded top and some flat top. In all cases, the Neck pickup tone is very deep and the Bridge pickup tone is bright. This allows the widest tonal sweep from the Blend control. Enjoy the wide tonal range!"

- Bill Bartolini -



### SR5000E OL

- 3pc SR4 Prestige Wenge / Bubinga neck 22 fret
- Wenge/Mahogany/Wenge body
- Medium frets
- MR-4 bridge (19mm string spacing)
- USA Bartolini® Custom neck pu
- USA Bartolini® Custom bridge pu
- PWC III 3-band eq
- Elair® strings
- Hardware color: GD
- Scale: 864mm/34"
- Color: OL(Oil)



### SR5005E OL

- 3pc SR5 Prestige Wenge / Bubinga neck 22 fret
- Wenge/Mahogany/Wenge body
- Medium frets
- MR-4 bridge (16.5mm string spacing)
- USA Bartolini® Custom neck pu
- USA Bartolini® Custom bridge pu
- PWC III 3-band eq
- Elair® strings
- Hardware color: GD
- Scale: 864mm/34"
- Color: OL(Oil)

### SR5006E OL

- 3pc SR6 Prestige Wenge / Bubinga neck 22 fret
- Wenge/Mahogany/Wenge body
- Medium frets
- MR-4 bridge (16.5mm string spacing)
- USA Bartolini® Custom neck pu
- USA Bartolini® Custom bridge pu
- PWC III 3-band eq
- Elair® strings
- Hardware color: GD
- Scale: 864mm/34"
- Color: OL(Oil)

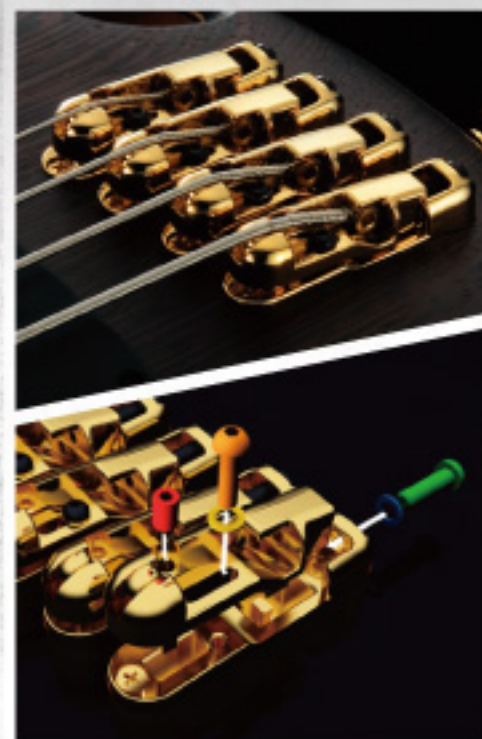

### MR4 Mono-Rail Bridge

The Mono-Rail Bridge is the ultimate in string isolation for bass. Each saddle is independently and securely locked down to the body for maximum vibration transfer and no interference. One screw controls the height of each saddle for easy adjustment.



### Power Curve III EQ

The new Power Curve III 3-band EQ was developed specifically for the new SR Prestige line. The Mid Q control makes adjustment of the core of your bass tone (the mids) extremely simple. EQ variable range makes it possible to get very natural sounding bass tones.

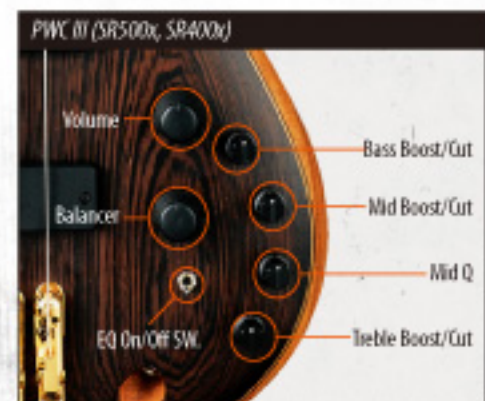

SOUNDGEAR

# SR 4 STRING

Since 1987, musicians all over the world have come to know the playing comfort and unique sound of the SR bass. This year's lineup includes a wide array of options sure to fit just about any style of music.



### Bartolini® MK1 Pickups

The MK1 pickups are split coil designs that provides a very wide frequency range and enhanced definition for maximum accuracy. The Neck and Bridge pickups have equal response, like traditional single coils, but without the hum and noise.

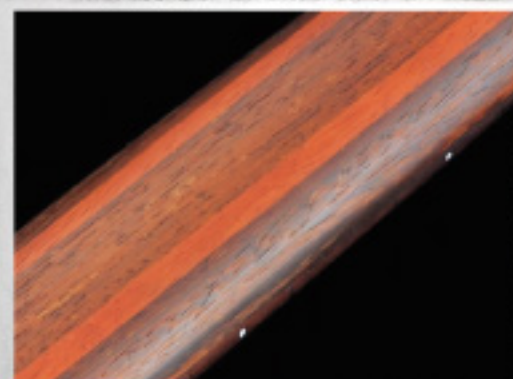

### Jatoba/Bubinga Slim Neck

Coupling Jatoba with Bubinga has made the neck strong and stable despite its thinness.



### SR700 AM

- 5pc SR4 Jatoba /Bubinga neck
- Figured Maple /Mahogany wing body w/Maple center block
- Medium frets
- Accu-Cast B20 bridge (19mm string spacing)
- Bartolini® MK1 neck pu
- Bartolini® MK1 bridge pu
- Bartolini® MK1 3-band eq
- Elbit® strings
- Hardware color: CK
- Scale: 864mm/34"
- Color: AM (Amber)

### SR500 BM

- 5pc SR4 Jatoba /Bubinga neck
- Mahogany body
- Medium frets
- Accu-Cast B20 bridge (19mm string spacing)
- Bartolini® MK1 neck pu
- Bartolini® MK1 bridge pu
- Elbit® strings
- Hardware color: CK
- Scale: 864mm/34"
- Color: BM (Brown Mahogany)

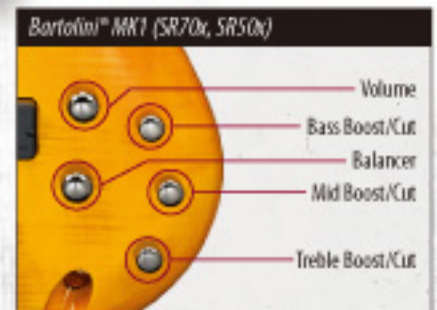

### SR4000E TKF

- 5pc SR4 Prestige Wenge /Bubinga neck
- Mahogany body
- Medium frets
- MR-4 bridge (19mm string spacing)
- USA Bartolini® Custom neck pu
- USA Bartolini® Custom bridge pu
- PWC II 3-band eq
- Elbit® strings
- Hardware color: CK
- Scale: 864mm/34"
- Colors: SDR (Stained Red) TKF (Transparent Black Flat)

### SR4005E SDR

- 5pc SRS Prestige Wenge /Bubinga neck
- Mahogany body
- Medium frets
- MR-4 bridge (16.5mm string spacing)
- USA Bartolini® Custom neck pu
- USA Bartolini® Custom bridge pu
- PWC II 3-band eq
- Elbit® strings
- Hardware color: CK
- Scale: 864mm/34"
- Colors: SDR (Stained Red) TKF (Transparent Black Flat)

### SR4000E SDR

- 5pc SR4 Prestige Wenge /Bubinga neck
- Mahogany body
- Medium frets
- MR-4 bridge (19mm string spacing)
- USA Bartolini® Custom neck pu
- USA Bartolini® Custom bridge pu
- PWC II 3-band eq
- Elbit® strings
- Hardware color: CK
- Scale: 864mm/34"
- Colors: SDR (Stained Red) TKF (Transparent Black Flat)

### SR4005E TKF

- 5pc SRS Prestige Wenge /Bubinga neck
- Mahogany body
- Medium frets
- MR-4 bridge (16.5mm string spacing)
- USA Bartolini® Custom neck pu
- USA Bartolini® Custom bridge pu
- PWC II 3-band eq
- Elbit® strings
- Hardware color: CK
- Scale: 864mm/34"
- Colors: SDR (Stained Red) TKF (Transparent Black Flat)

SOUNDGEAR  
**SR** Prestige

# SOUNDGEAR

# SR

## 4 STRING



### 3 Band EQ, Style Sweeper Controls

With the Style Sweeper 3-Band EQ controls, you can boost mids for a plucky finger sound or scoop them for a resonant slap sound with the turn of a knob.

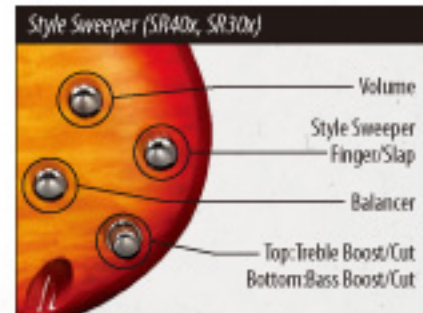

### SR400QM CS

- 5pc SR4 Maple /Rosewood neck
- Quilted Maple top /Basswood body
- Medium frets
- Accu-Cast B20 bridge (19mm string spacing)
- EXF-4F neck pu
- EXF-4R bridge pu
- EQB-11B Style Sweeper 3-band eq
- Hardware color: CK
- Scale: 864mm/34"
- Colors: CS (Cherry Sunburst)

TLB (Transparent Lavender Burst)

### SR400QM TLB

- 5pc SR4 Maple /Rosewood neck
- Quilted Maple top /Basswood body
- Medium frets
- Accu-Cast B20 bridge (19mm string spacing)
- EXF-4F neck pu
- EXF-4R bridge pu
- EQB-11B Style Sweeper 3-band eq
- Hardware color: CK
- Scale: 864mm/34"
- Colors: CS (Cherry Sunburst)

TLB (Transparent Lavender Burst)



### SR300 IPT

- 5pc SR4 Maple /Rosewood neck
- Agathis body
- Medium frets
- B100 bridge (19mm string spacing)
- EXF-4F neck pu
- EXF-4R bridge pu
- EQB-11B Style Sweeper 3-band eq
- Hardware color: CK
- Scale: 864mm/34"
- Colors: CA (Candy Apple)
- IPT (Iron Pewter)
- SLB (Starlight Blue)

### SR300 SLB

- 5pc SR4 Maple /Rosewood neck
- Agathis body
- Medium frets
- B100 bridge (19mm string spacing)
- EXF-4F neck pu
- EXF-4R bridge pu
- EQB-11B Style Sweeper 3-band eq
- Hardware color: CK
- Scale: 864mm/34"
- Colors: CA (Candy Apple)
- IPT (Iron Pewter)
- SLB (Starlight Blue)

### SR300 CA

- 5pc SR4 Maple /Rosewood neck
- Agathis body
- Medium frets
- B100 bridge (19mm string spacing)
- EXF-4F neck pu
- EXF-4R bridge pu
- EQB-11B Style Sweeper 3-band eq
- Hardware color: CK
- Scale: 864mm/34"
- Colors: CA (Candy Apple)
- IPT (Iron Pewter)
- SLB (Starlight Blue)

### SR300L IPT

- 5pc SR4 Maple /Rosewood neck
- Agathis body
- Medium frets
- B100 bridge (19mm string spacing)
- EXF-4F neck pu
- EXF-4R bridge pu
- EQB-11B Style Sweeper 3-band eq
- Hardware color: CK
- Scale: 864mm/34"
- Color: IPT (Iron Pewter)



### SR505 BM

- 3pc SRS Jatoba/Bubinga neck
- Mahogany body
- Medium frets
- Accu-Cast B25 bridge (16.5mm string spacing)
- Bartolini® MK1 neck pu
- Bartolini® MK1 bridge pu
- Bartolini® MK1 3-band eq
- Elbit® strings
- Hardware color : CK
- Scale : 864mm/34"
- Color : BM (Brown Mahogany)



### SR405QM CNB

- 3pc SRS Maple/Rosewood neck
- Quilted Maple top
- Basswood body
- Medium frets
- Accu-Cast B25 bridge (16.5mm string spacing)
- EXF-SF neck pu
- EXF-SR bridge pu
- EQB-88 Style Sweeper 3-band eq
- Hardware color : CK
- Scale : 864mm/34"
- Color : CNB (Charcoal Brown Burst)



### SR305 IPT

- 3pc SRS Maple/Rosewood neck
- Agathis body
- Medium frets
- B105 bridge (16.5mm string spacing)
- EXF-SF neck pu
- EXF-SR bridge pu
- EQB-88 Style Sweeper 3-band eq
- Hardware color : CK
- Scale : 864mm/34"
- Color : IPT (Iron Peaster)



### SR705 BLM

- 3pc SRS Jatoba/Bubinga neck
- Figured Maple/Mahogany wing body w/Maple center block
- Medium frets
- Accu-Cast B25 bridge (16.5mm string spacing)
- Bartolini® MK1 neck pu
- Bartolini® MK1 bridge pu
- Bartolini® MK1 3-band eq
- Elbit® strings
- Hardware color : CK
- Scale : 864mm/34"
- Color : BLM (Blue Moon)



### SR706 TK

- 3pc SRS Jatoba/Bubinga neck
- Figured Maple/Mahogany wing body w/Maple center block
- Medium frets
- B106 bridge (16.5mm string spacing)
- Bartolini® MK1 neck pu
- Bartolini® MK1 bridge pu
- Bartolini® MK1 3-band eq
- Elbit® strings
- Hardware color : CK
- Scale : 864mm/34"
- Color : TK (Transparent Black)



### SR506 BM

- 3pc SRS Jatoba/Bubinga neck
- Mahogany body
- Medium frets
- B106 bridge (16.5mm string spacing)
- Bartolini® MK1 neck pu
- Bartolini® MK1 bridge pu
- Bartolini® MK1 3-band eq
- Elbit® strings
- Hardware color : CK
- Scale : 864mm/34"
- Color : BM (Brown Mahogany)



# SOUNDGEAR SR 6 STRING



### GSR206 BK

- 1pc GSR6 Maple neck
- Agathis body
- Medium frets
- B15 bridge (16.5mm string spacing)
- DXH-6N neck pu
- DXH-6B bridge pu
- Phat II eq
- Hardware color : CH
- Scale : 864mm/34"
- Color : BK (Black)



# SR

5 STRING

# GSR



## GSR200FM TBB

- 1pc GSR4 Maple neck
- Flamed Maple top
- Nato body
- Medium frets
- B10 bridge (19mm string spacing)
- STD-P2 neck pu
- STD-J2 bridge pu
- Phat II eq
- Hardware color : CH
- Scale : 864mm/34"
- Colors : AMB (Amber Burst)
- TBB (Transparent Blue Burst)

## GSR200FM AMB

- 1pc GSR4 Maple neck
- Flamed Maple top
- Nato body
- Medium frets
- B10 bridge (19mm string spacing)
- STD-P2 neck pu
- STD-J2 bridge pu
- Phat II eq
- Hardware color : CH
- Scale : 864mm/34"
- Colors : AMB (Amber Burst)
- TBB (Transparent Blue Burst)

## GSR205FM TK

- 1pc GSR5 Maple neck
- Flamed Maple top
- Nato body
- Medium frets
- B15 bridge (16.5mm string spacing)
- STD-J51 neck pu
- STD-J52 bridge pu
- Phat II eq
- Hardware color : CH
- Scale : 864mm/34"
- Color : TK (Transparent Black)

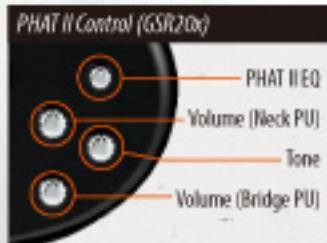

## GSR200 BK

## GSR200 JB

## GSR200 TR

## GSR200 PW

## GSR205 BK

- 1pc GSR4 Maple neck
- Agathis body
- Medium frets
- B10 bridge (19mm string spacing)
- PSNDP neck pu
- PSNDJ bridge pu
- Phat II eq
- Hardware color : CH
- Scale : 864mm/34"
- Colors : BK (Black)
- JB (Jewel Blue)
- PW (Pearl White)
- TR (Transparent Red)

- 1pc GSR5 Maple neck
- Agathis body
- Medium frets
- B15 bridge (16.5mm string spacing)
- DXS-1 neck pu
- DXS-2 bridge pu
- Phat II eq
- Hardware color : CH
- Scale : 864mm/34"
- Color : BK (Black)

## GSR100EX TMM

- 1pc GSR4 Maple neck
- Mahogany body
- Medium frets
- B10 bridge (19mm string spacing)
- PPD4 pu
- Hardware color : CH
- Scale : 864mm/34"
- Colors : BK (Black)
- TMM (Traditional Matte Mahogany)

## GSR100EX BK

- 1pc GSR4 Maple neck
- Basswood body
- Medium frets
- B10 bridge (19mm string spacing)
- PPD4 pu
- Hardware color : CH
- Scale : 864mm/34"
- Colors : BK (Black)
- TMM (Traditional Matte Mahogany)

## GSR105EX BK

- 1pc GSR5 Maple neck
- Basswood body
- Medium frets
- B15 bridge (16.5mm string spacing)
- PPD5 pu
- Hardware color : CH
- Scale : 864mm/34"
- Color : BK (Black)

# SRX

The SRX is the muscular big brother of the SR series. This is a bass that was designed for heavier playing styles, and it meets that demand in a no-nonsense layout. The EQB-IIDX 2-band EQ makes it easy to find sounds, and the now famous stock Ibanez PFR pickups that major artists rave about give you that extra punch.



## PFR Pickups and EQB-IIDX EQ

These powerful full-range passive pickups generate high output with extra low midrange punch. The EQB-IIDX 2-band EQ enhances heavy tones with simple operation.



## SRX690DX TMR

- 3pc SRX4 Maple/Bubinga neck-thru
- Quilted Maple top
- Mahogany wing body
- Medium frets
- Accu-Cast B200 bridge (19mm string spacing)
- PFR-N4 neck pu
- PFR-B4 bridge pu
- EQB-II DX 2-band eq
- Elbix® strings
- Hardware color : GD
- Scale : 864mm/34"
- Color : TMR (Transparent Madder Red)



## SRX470 MBK

- 3pc SRX4 Maple neck
- Mahogany body
- Medium frets
- Accu-Cast B200 bridge (19mm string spacing)
- PFR-N4 neck pu
- PFR-B4 bridge pu
- EQB-II DX 2-band eq
- Hardware color : BK
- Scale : 864mm/34"
- Colors : MBK (Metallic Black)  
PW (Pearl White)



## SRX470 PW

- 3pc SRX4 Maple neck
- Mahogany body
- Medium frets
- Accu-Cast B200 bridge (19mm string spacing)
- PFR-N4 neck pu
- PFR-B4 bridge pu
- EQB-II DX 2-band eq
- Hardware color : BK
- Scale : 864mm/34"
- Colors : MBK (Metallic Black)  
PW (Pearl White)



## SRX695DX TG

- 3pc SRX5 Maple
- Bubinga neck-thru
- Quilted Maple top
- Mahogany wing body
- Medium frets
- Accu-Cast B205 bridge (18mm string spacing)
- PFR-N5 neck pu
- PFR-B5 bridge pu
- EQB-II DX 2-band eq
- Elbix® strings
- Hardware color : GD
- Scale : 864mm/34"
- Color : TG (Transparent Gray)



## SRX475 TGY

- 3pc SRX5 Maple neck
- Mahogany body
- Medium frets
- Accu-Cast B205 bridge (18mm string spacing)
- PFR-N5 neck pu
- PFR-B5 bridge pu
- EQB-II DX 2-band eq
- Hardware color : BK
- Scale : 864mm/34"
- Color : TGY (Titanium Gray)



## EQB-II DX (SRX)

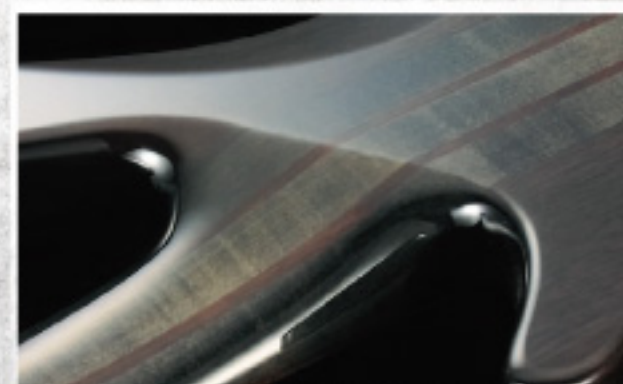

## Neck-Thru Construction (SRX69x) Ⓢ

Neck-Thru construction on the SRX690s offers massive sustain and maximizes playability.



# BTB

## 4 STRING

### Nature of the Beast

The concepts behind boutique basses are often justification for making them extremely expensive. With the advent of the BTB, Ibanez decided that these same concepts of well-selected body materials, 35"

neck scale, and deep cutaways could be applied to an instrument that anyone could afford. The new BTB770s sport exquisite Poplar Burl tops in gloss finishes and powerful Bartolini® MK2 pickups exclusively designed for the BTB.



Ibanez DFR Pickups & 3-band EQ

The BTB300s feature the Ibanez DFR passive pickups with 3-band EQ delivering a variety of tones and superior dynamics.



#### BTB670 NTF

- 3pc BTB4 Maple /Bubinga neck-thru
- Walnut/Light Ash wing body
- Medium frets
- MR-2 bridge (19mm string spacing)
- Bartolini® MK2 neck pu
- Bartolini® MK2 bridge pu
- Bartolini® MK2 3-band eq
- Elber® strings
- Hardware color : CK
- Scale : 889mm/35"
- Color : NTF (Natural Flat)

#### BTB300FM AMB

- 3pc BTB4 Maple neck
- Flamed Maple top /Mahogany body
- Medium frets
- B100 bridge (19mm string spacing)
- DFR-N4 neck pu
- DFR-B4 bridge pu
- EQB-11C 3-band eq
- Elber® strings
- Hardware color : CK
- Scale : 889mm/35"
- Color : AMB (Amber Burst)

#### BTB200 MKF

- 3pc BTB4 Maple neck
- Mahogany body
- Medium frets
- B100 bridge (19mm string spacing)
- DX-N4 neck pu
- DX-B4 bridge pu
- PHAT II eq
- Elber® strings
- Hardware color : CK
- Scale : 889mm/35"
- Color : MKF (Metallic Black Flat)

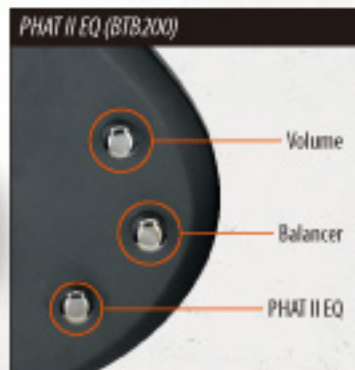
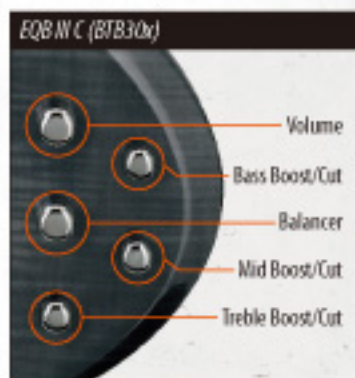

#### BTB675 NTF

- 3pc BTB5 Maple /Bubinga neck-thru
- Walnut/Light Ash wing body
- Medium frets
- MR-2 bridge (19mm string spacing)
- Bartolini® MK2 neck pu
- Bartolini® MK2 bridge pu
- Bartolini® MK2 3-band eq
- Elber® strings
- Hardware color : CK
- Scale : 889mm/35"
- Color : NTF (Natural Flat)

#### BTB305FM TK

- 3pc BTB5 Maple neck
- Flamed Maple top /Mahogany body
- Medium frets
- B105 bridge (16.5mm string spacing)
- DFR-N5 neck pu
- DFR-B5 bridge pu
- EQB-11C 3-band eq
- Elber® strings
- Hardware color : CK
- Scale : 889mm/35"
- Color : TK (Transparent Black)

# BTB

## 5 STRING

#### BTB775PB CN

- 3pc BTB5 Maple /Bubinga neck-thru
- Poplar Burl top /Mahogany wing body
- Medium frets
- MR-2 bridge (19mm string spacing)
- Bartolini® MK2 neck pu
- Bartolini® MK2 bridge pu
- Bartolini® MK2 3-band eq
- Elber® strings
- Hardware color : CK
- Scale : 889mm/35"
- Color : CN (Charcoal Brown)



Bartolini® MK2 Pickups and EQ

The MK2 pickups are quad coil designs. The Neck pickup tone is very deep and the Bridge pickup tone is bright, just like the US made pickups. They are also balanced for output so that the deep tone Neck pickup does not overpower the Bridge pickup. The MK2 electronics compliments and enhances their wide tonal range.

# BTB

6 STRING

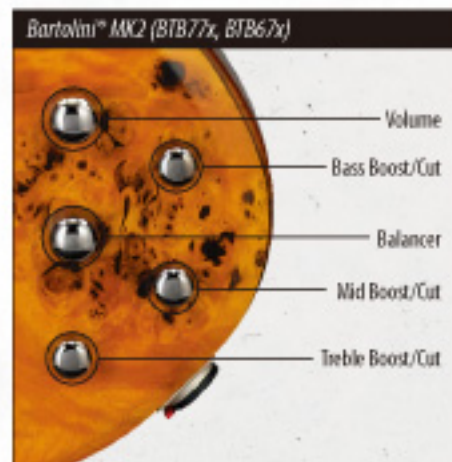

## BTB676 NTF

- 3pc BTB6 Maple /Bubinga neck-thru
- Walnut/Light Ash wing body
- Medium frets
- MR-2 bridge (17mm string spacing)
- Bartolini<sup>®</sup> MK2 neck pu
- Bartolini<sup>®</sup> MK2 bridge pu
- Bartolini<sup>®</sup> MK2 3-band eq
- Elitist<sup>®</sup> strings
- Hardware color : CK
- Scale : 809mm/31"
- Color : NTF (Natural Flat)

## BTB776PB AM

- 3pc BTB6 Maple /Bubinga neck-thru
- Poplar Burl top
- Mahogany wing body
- Medium frets
- MR-2 bridge (17mm string spacing)
- Bartolini<sup>®</sup> MK2 neck pu
- Bartolini<sup>®</sup> MK2 bridge pu
- Bartolini<sup>®</sup> MK2 3-band eq
- Elitist<sup>®</sup> strings
- Hardware color : CK
- Scale : 809mm/31"
- Color : AM (Amber)

# ICB

The Iceman has long been one of the more adventurous body styles from Ibanez. In the bass world, it means a massive piece of mahogany and high powered pickups to create tones that are absolutely earth shattering.



## PFR Pickups and EQB-IIDX EQ

These powerful full-range passive pickups generate high output with extra low midrange punch. The EQB-IIDX 2-band EQ enhances heavy tones with simple operation.



## ARTB100 BK

- 3pc ARTB Mahogany /Maple set-in neck
- Mahogany body
- Medium frets
- Gibraltar III bass bridge (19mm string spacing)
- Quik Change III bass tailpiece
- ACHB-2 neck pu
- ACHB-2 bridge pu
- Hardware color : CH
- Scale : 770mm/30.3"
- String Gauge : .050 / .070 / .085 / .105
- Colors : BK (Black) WH (White)

## ARTB100 WH

- 3pc ARTB Mahogany /Maple set-in neck
- Mahogany body
- Medium frets
- Gibraltar III bass bridge (19mm string spacing)
- Quik Change III bass tailpiece
- ACHB-2 neck pu
- ACHB-2 bridge pu
- Hardware color : CH
- Scale : 770mm/30.3"
- String Gauge : .050 / .070 / .085 / .105
- Colors : BK (Black) WH (White)



## ICB300EX BK

- 3pc ICB4 Maple neck
- Mahogany body
- Medium frets
- B100 bridge (19mm string spacing)
- PFR-N4 neck pu (black pole piece)
- PFR-B4 bridge pu (black pole piece)
- EQB-II DX 2-band eq
- Elitist<sup>®</sup> strings
- Hardware color : BK
- Scale : 864mm/34"
- Colors : BK (Black) WH (White)

## ICB300EX WH

- 3pc ICB4 Maple neck
- Mahogany body
- Medium frets
- B100 bridge (19mm string spacing)
- PFR-N4 neck pu (black pole piece)
- PFR-B4 bridge pu (black pole piece)
- EQB-II DX 2-band eq
- Elitist<sup>®</sup> strings
- Hardware color : BK
- Scale : 864mm/34"
- Colors : BK (Black) WH (White)

# ARTB

For those who prefer a bass that has a more classic feel to it, the ARTB is a 70s style rock machine. The combination of the mahogany body, the 30.3" short scale length and set neck create a warm tone that recreates the days of arena rock. The short scale neck is also comfortable for smaller hands.

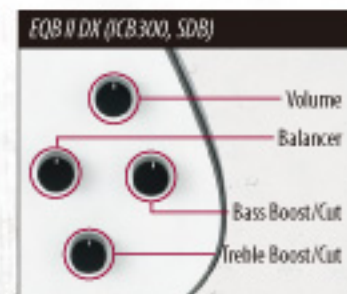
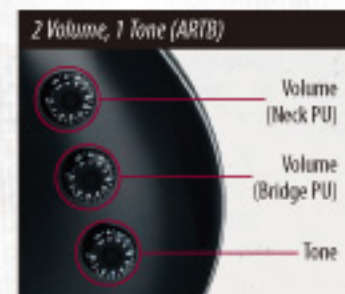



PETER IWERS  
(IN FLAMES)

PIB1



PIB1  
BK

- 3pc PIB Maple/bubinga neck-thru
- Maple wing body
- Medium frets
- MR-4 bridge (16.5mm string spacing)
- USA Bartolini® Custom neck pu
- USA Bartolini® Custom bridge pu
- 1-volume control w/PIB Active circuit
- D'Addario® strings
- Hardware color: GD
- Scale: 864mm/34"
- Factory Tuning: 1D#, 2A#, 3F, 4C, 5A#
- String Gauge: .045/.065/.085/.105/.120
- Color: BK (Black)



SHARLEE D'ANGELO  
(ARCH ENEMY)

SDB1

BKF

- 3pc SDB Maple
- Bubinga neck-thru
- Mahogany wing body
- Medium frets
- MR-4 bridge (19mm string spacing)
- PFR-N4 neck pu (black pole piece)
- PFR-B4 bridge pu (black pole piece)
- EQB-II DK 2-band eq
- D'Addario® strings
- Hardware color: CK
- Scale: 864mm/34"
- Factory Tuning: 1D#, 2A#, 3F, 4C
- String Gauge: .060/.080/.100/.120
- Color: BKF (Black Flat)



PAUL ROMANKO  
(SHADOWS FALL)

PRB2

PRB2  
BWF

- 3pc PRB Maple/Walnut neck
- Swamp Ash wing/Swamp Ash center w/Walnut stripe body
- Medium frets
- MR-4 bridge (19mm string spacing)
- PFR-ALN4 neck pu
- PFR-ALB4 bridge pu
- 1-volume control w/PRB Active circuit
- D'Addario® strings
- Hardware color: CK
- Scale: 864mm/34"
- Factory Tuning: 1F, 2C, 3G, 4D
- String Gauge: .050/.070/.085/.105
- Color: BWF (Burgundy Wine Flat)



PAUL GRAY  
(SLIPKNOT)

PGB1

BGW

- 3pc PGB Maple neck
- Swamp Ash body
- Jumbo frets
- ATK4 bridge (19mm string spacing)
- ATK triple coil pu
- ATK 3-band eq
- D'Addario® strings
- Hardware color: CK
- Scale: 864mm/34"
- Factory Tuning: 1D, 2A, 3E, 4B
- String Gauge: .050/.070/.090/.110
- Color: BGW (Burgundy Wine)



- 3pc PGB Maple neck
- Swamp Ash body
- Jumbo frets
- ATK4 bridge (19mm string spacing)
- ATK triple coil pu
- ATK 3-band eq
- D'Addario® strings
- Hardware color: CK
- Scale: 864mm/34"
- Factory Tuning: 1D, 2A, 3E, 4B
- String Gauge: .050/.070/.090/.110
- Color: BGW (Burgundy Wine)



MIKE D'ANTONIO  
(KILLSWITCH ENGAGE)

MDB2

BM

- 3pc MDB Maple/Walnut neck-thru
- Mahogany wing body
- Medium frets
- Accu-Cast B200 bridge (19mm string spacing)
- PFR-ALN4 neck pu
- PFR-ALB4 bridge pu
- 1-volume control w/MDB Active circuit
- D'Addario® strings
- Hardware color: CK
- Scale: 864mm/34"
- Factory Tuning: 1F, 2C, 3G, 4C
- String Gauge: .055/.075/.095/.120
- Color: BM (Brown Mahogany)



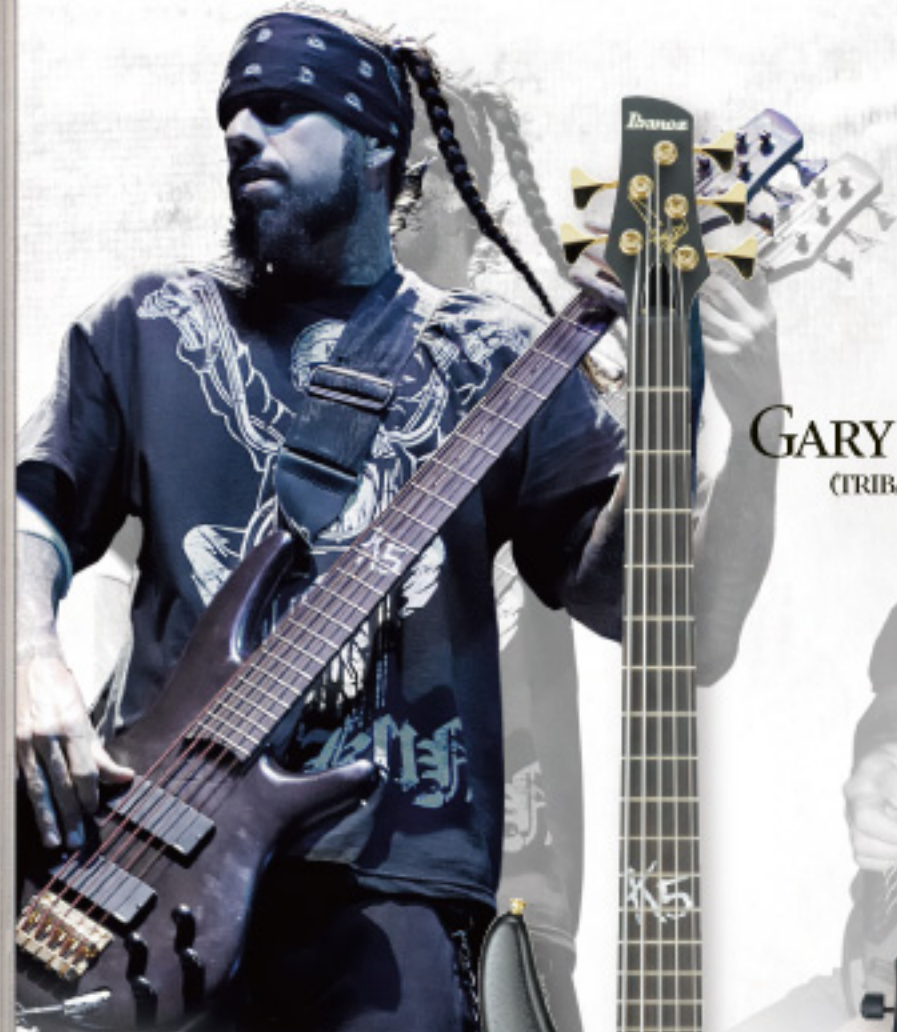

**GARY WILLIS**  
(TRIBAL TECH)

**FIELDY**  
(KORN)

**K5**  
TKF

- 3pc K5 Maple/Bubinga neck
- Mahogany body
- Medium frets
- Die-Cast EB-7 bridge (16.5mm string spacing)
- ADXSN neck pu
- ADXSB bridge pu
- Vari-Mid III 3-band eq
- Elbit® strings
- Hardware color: GD
- Scale: 864mm/34"
- Color: TKF (Transparent Black Flat)

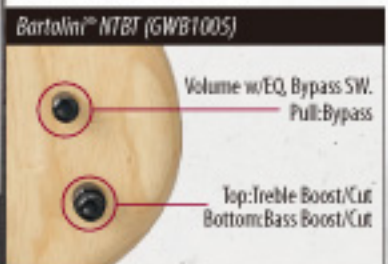
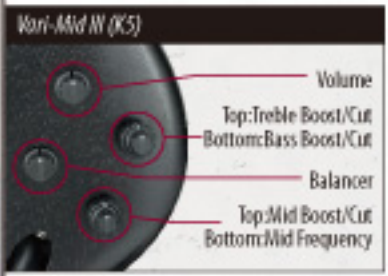

**GWB1005**  
NTF

- 3pc GWB1005 Maple neck (3-ply)
- Swamp Ash body
- Fretless
- STD-5 bridge (16.5mm string spacing)
- Bartolini® GWB pu
- Bartolini® NTBT 2-band eq
- D'Addario® strings
- Hardware color: BK
- Scale: 864mm/34"
- Color: NTF (Natural Flat)



**GWB35**  
BKF

- 3pc GWB35 neck
- Basswood body
- Fretless
- B105 bridge (16.5mm string spacing)
- SFR-GWB custom wound pu
- EQB-GWB 2-band eq
- D'Addario® strings
- Hardware color: BK
- Scale: 864mm/34"
- Color: BKF (Black Flat)



**EDB550**  
WNF

- 3pc EDB4 Jatoba/Bubinga neck
- Light Ash body
- Medium frets
- B105 bridge (16mm string spacing)
- Duncan®/Ibanez neck pu
- Duncan®/Ibanez bridge pu
- EQB-II DX 2-band eq
- Elbit® strings
- Hardware color: CK
- Scale: 864mm/34"
- Color: WNF (Walnut Flat)



**EDB555**  
WNF

- 3pc EDB5 Jatoba/Bubinga neck
- Light Ash body
- Medium frets
- B105 bridge (16.5mm string spacing)
- Duncan®/Ibanez neck pu
- Duncan®/Ibanez bridge pu
- EQB-II DX 2-band eq
- Elbit® strings
- Hardware color: CK
- Scale: 864mm/34"
- Color: WNF (Walnut Flat)



# EDB

RGODYNE

**E**very aspect of the EDB was designed with playing comfort in mind. The ergonomic body is contoured. The 5 piece Jatoba/Bubinga neck is exceptionally strong and slightly thicker than the SR bass. The EQB-II DX 2-band EQ makes any sound you want possible.

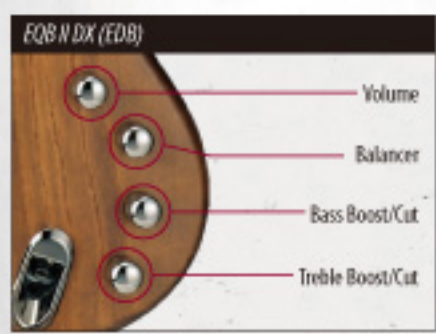

**Duncan®/IBZ Pickups** Duncan®/Ibanez pickups on EDB550s.



**Scooped-out** Scooped-out front for slapping and popping.

# ATK

The ATK may be the most straightforward bass in the entire Ibanez line.

This simple rock n' roll bass with a punk attitude combines a large ash body with a maple neck for big tight sounds. The special ATK triple coil pickups can only be found on these basses. Coupled with the 3-band EQ, this bass can generate some serious low end punch.

## ATK310 WH

- 3pc ATK4 Maple neck
- Light Ash body
- Jumbo frets
- ATK4 bridge (19mm string spacing)
- ATK Triple coil pu
- ATK 3-band eq
- Elisk® strings
- Hardware color: CH
- Scale: 864mm/34"
- Colors: BK (Black)  
WH (White)

## ATK310 BK

- 3pc ATK4 Maple neck
- Light Ash body
- Jumbo frets
- ATK4 bridge (19mm string spacing)
- ATK Triple coil pu
- ATK 3-band eq
- Elisk® strings
- Hardware color: CH
- Scale: 864mm/34"
- Colors: BK (Black)  
WH (White)

## ATK300 NT

- 3pc ATK4 Maple neck
- Light Ash body
- Jumbo frets
- ATK4 bridge (19mm string spacing)
- ATK Triple coil pu
- ATK 3-band eq
- Elisk® strings
- Hardware color: CH
- Scale: 864mm/34"
- Color: NT (Natural)

## ATK305 NT

- 3pc ATK5 Maple neck
- Light Ash body
- Jumbo frets
- ATK5 bridge (17mm string spacing)
- ATK Triple coil pu
- ATK 3-band eq
- Elisk® strings
- Hardware color: CH
- Scale: 864mm/34"
- Color: NT (Natural)



With the ingenious ATK bridge, you have the option to string through-the-body for increased low end and more sustain, or through-the-bridge for slightly more high end and attack. (A) (V)



### ATK Triple Coil Pickup (V)

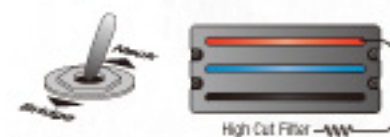

**Trad** Single Coil Sound + High Cut Filter



**Bright** Single Coil Sound



**Attack** Humbucker Sound (Parallel)

Red: Active Coil Blue: Passive Coil (By Hook Circuit) Black: Inactive Coil

### ATK 3 BAND EQ (ATK, PGB)

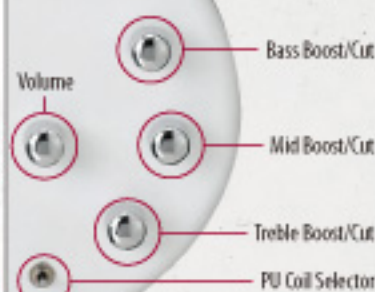

# JTKB

If you want a bass that transports you back to hot rods and 60s rock n' roll, then the JTKB is your golden ticket. Its mahogany body, high powered pickups and solid bridge can take a beating and still produce the warm passive sound of a vintage bass. The JTKB is truly unique among Ibanez basses.



**ACHB PU & Controls** The Jet King Bass is fitted with warm sounding ACHB pickups and classic knobs.

## JTKB200 BS

- 3pc JTKB4 Maple neck
- Mahogany body
- Medium frets
- JTB10 bridge (19mm string spacing)
- ACHB-2 neck pu
- ACHB-2 bridge pu
- Elixir® strings
- Hardware color: CH
- Scale: 864mm/34"
- Colors: BS (Brown Sunburst) RD (Red)



## JTKB200 RD

- 3pc JTKB4 Maple neck
- Mahogany body
- Medium frets
- JTB10 bridge (19mm string spacing)
- ACHB-2 neck pu
- ACHB-2 bridge pu
- Elixir® strings
- Hardware color: CH
- Scale: 864mm/34"
- Colors: BS (Brown Sunburst) RD (Red)



# ARTCORE

The Artcore Bass series was designed for players that are used to solid body basses but want the acoustic tone of a hollow body. The 30.3" scale neck increases playing comfort, and the acoustic body widens the palette of sounds at your disposal.

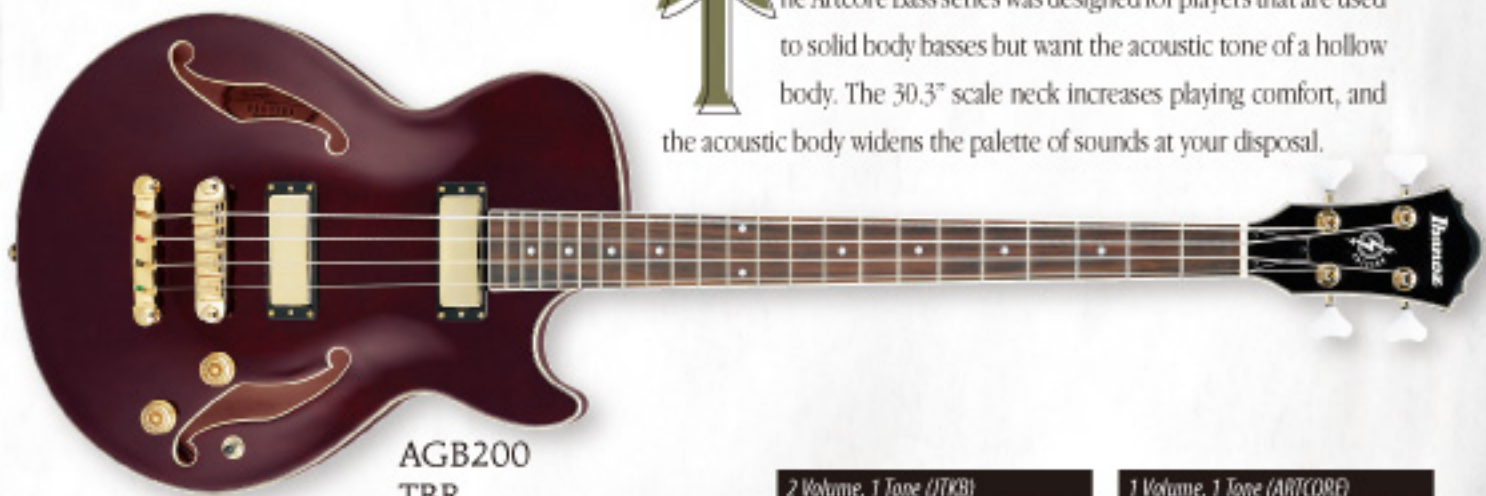

## AGB200 TBR

- 3pc Artcore Bass Mahogany /Maple set-in neck
- Maple top/back/sides
- Medium frets
- Gibraltar II bass bridge (19mm string spacing)
- Quik Change II bass tailpiece
- ACHB-2 neck pu
- ACHB-2 bridge pu
- Hardware color: GD
- Scale: 770mm/30.3"
- Depth: 43mm at tail
- String Gauge: .050/.070/.085/.105
- Color: TBR (Transparent Brown)

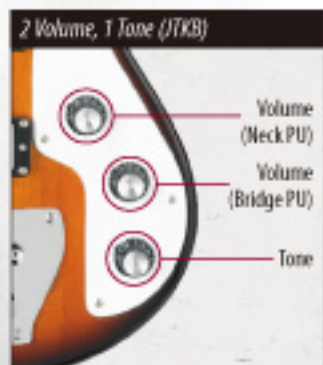

## Frequency Response Curves

**ATK 3 BAND EQ (ATK, PGB)**

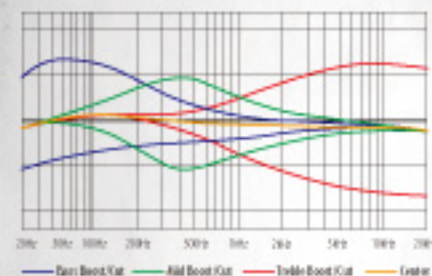

**Bartolini® MK-1 (SR)**

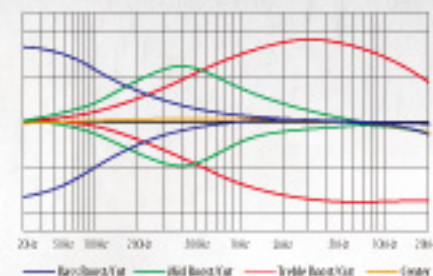

**Vari-Mid III (K5)**

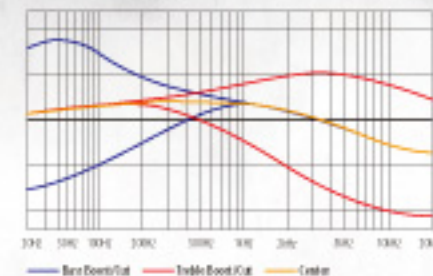

**Style Sweeper (SR)**

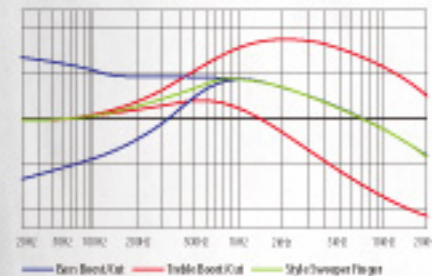

**Bartolini® MK-2 (BTB)**

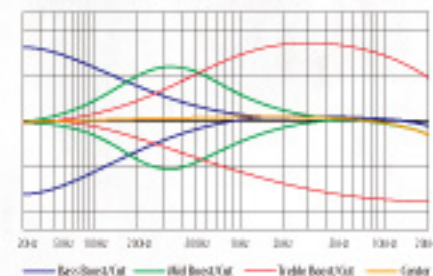

**Mid**

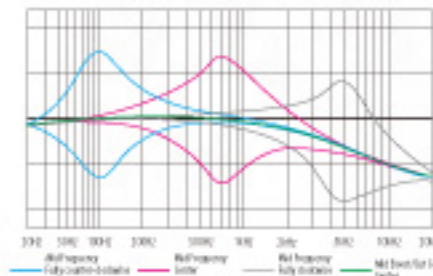

**Slapped**

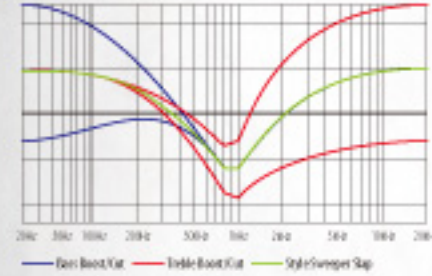

**Bartolini® NTBT (GWB1005)**

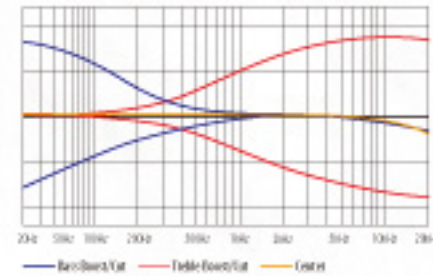

**Power Curve III (SR Prestige)**

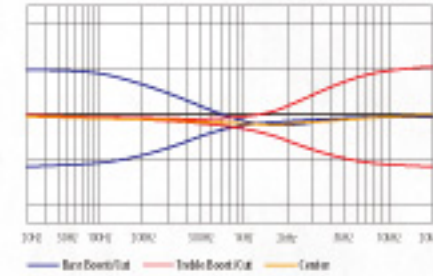

**EQB-IIIC (BTB)**

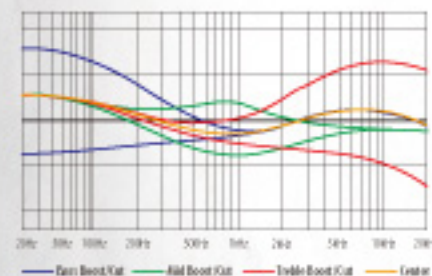

**PHAT-II (BTB, GSR)**

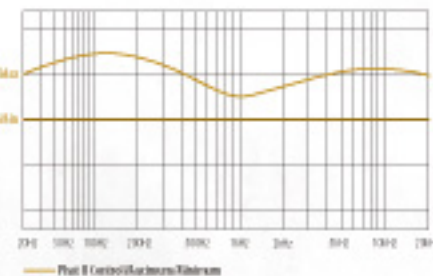

**Mid**

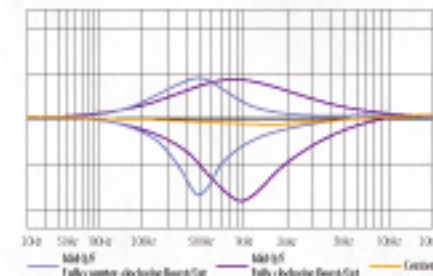

**EQB-GW II (GWB35)**

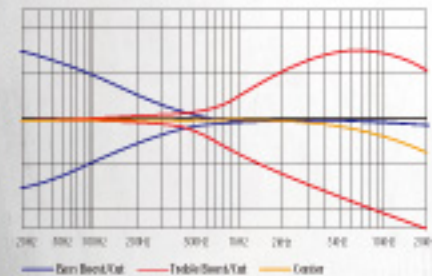

**EQB II DX (EDB, ICB, SDB, SRX)**

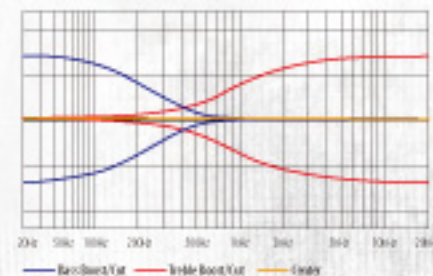

# JUMPSTART

When we say "Everything you need to get out and gig," we mean everything—amp, axe, accessories. All it takes is you and your desire to make your dreams real—to get out of the audiences and up on stage where you belong. It's in the cards. Go for it.

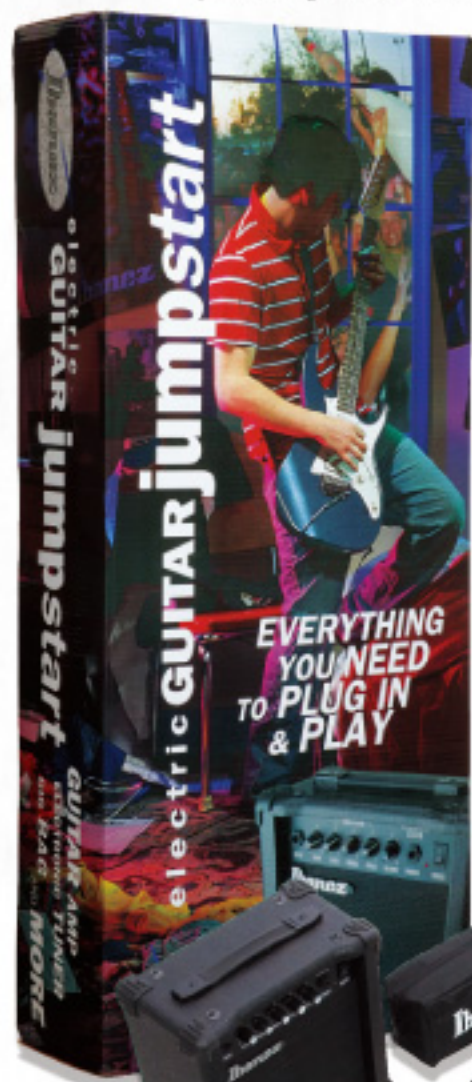

GRX40J  
CA

GRX40J  
JB

GRX40J  
BKN

## GRX40J -JUMPSTART-

Features GRX electric guitar and Jumpstart Guitar Package Accessories.

### Amplifier

- 10 watt dedicated guitar amp

### Package Accessories

- Electronic Tuner
- Gig Bag
- Guitar Strap
- Picks
- Accessories Pouch



GSR190J  
BK

GSR190J  
TR

## GSR190J -JUMPSTART-

Features GSR electric bass and Jumpstart Bass Package Accessories.

### Amplifier

- 15 watt dedicated bass amp

### Package Accessories

- Electronic Tuner
- Gig Bag
- Bass Guitar Strap
- Picks
- Accessories Pouch



# Ibanez Artists

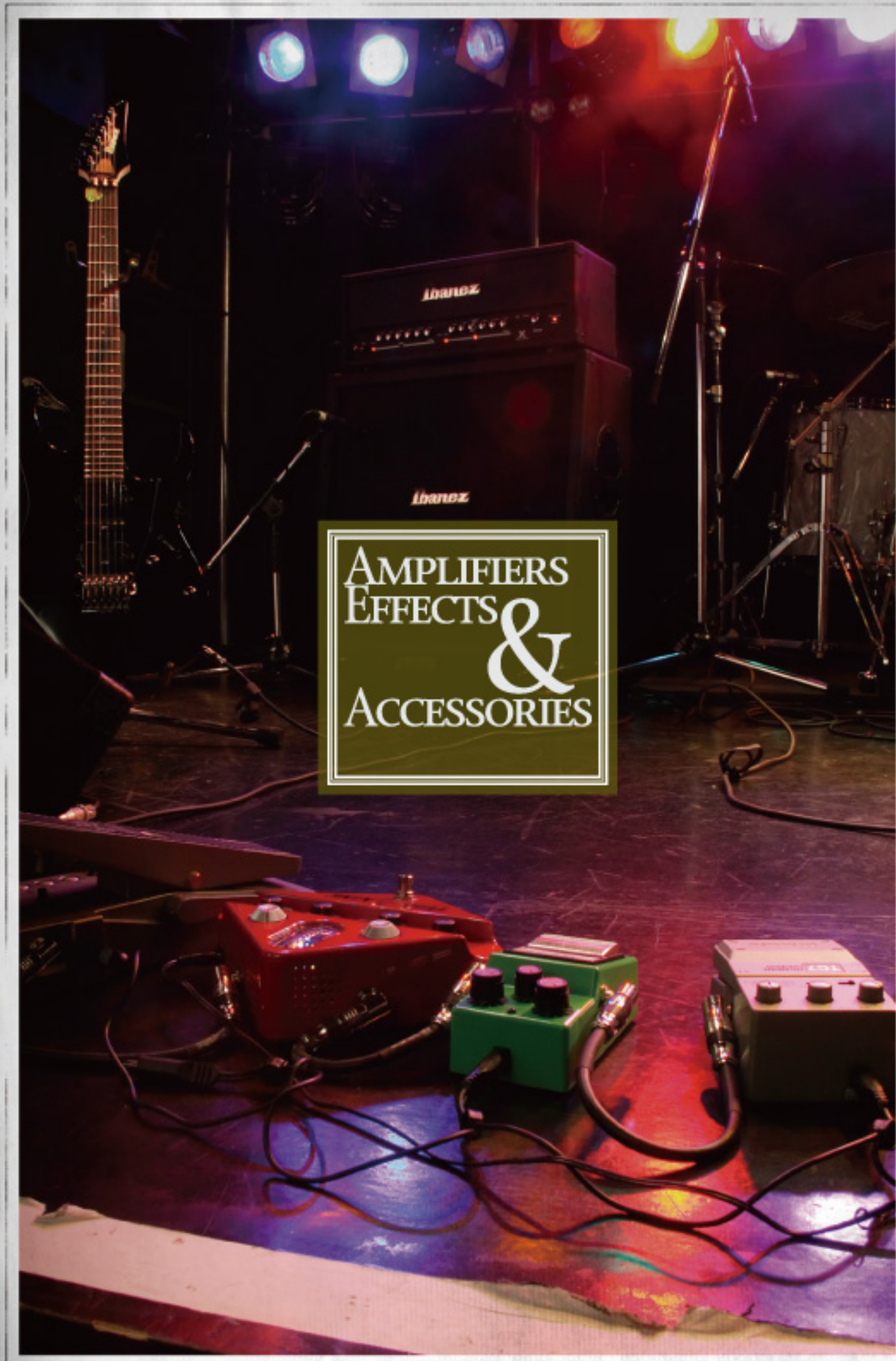

AMPLIFIERS  
EFFECTS  
&  
ACCESSORIES



# SOUND WAVE

The SWX Sound Wave Bass amp series is designed for today's bass players at all levels, who want serious versatility. The SWX delivers a thick, natural and balanced tone, while its perfect combination of

function allows you to change the tonal character without any hassle. Playing the Sound Wave will give you what you need for the groove, the drive, the pocket and the tones - whether you need traditional thump or today's pop, slap and funk.



## SWX100 100W Bass Amplifier

- output power 100Watts
- speaker unit 15" Bass speaker with Piezo Horn Tweeter
- controls Shape Switch, Bright Switch, Gain Level, Bass, Middle, Treble, Hue, Master Volume, Tweeter Switch, Auto-comp w/LED
- i/o's Input, CD / MP3 Input, Direct Out w/Post EQ Switch & GND Lift Switch, Effects Loop, Headphones
- cabinet Sealed Back Ported Bass Reflection Cabinet w/Caster
- size 520(W) x 642(H) x 312(D) (mm)
- weight 24.2kg



### HUE Control

All SoundWave SWX series bass amplifiers feature the HUE control, which adjusts overall tonal character.

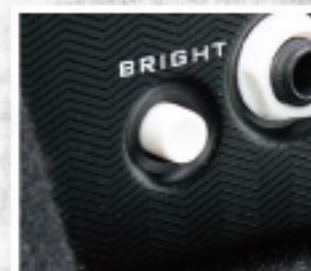

### Bright Switch

Selectable Normal and Bright modes change the sound character immediately, from the tone of passive bass to that of active bass.



### Shape Switch

Create the hi & low boost / mid cut sound instantly, which is one of the most desirable tones for many bass players.



### Internal Auto-Compression Circuit

All SoundWave SWX series bass amplifiers are equipped with internal auto compression circuitry, which minimizes distortion and keeps the sound clean and powerful. (SWX20 does not equip LED for Auto-Comp)



## SWX65 65W Bass Amplifier

- output power 65Watts
- speaker unit 12" Bass speaker with Piezo Horn Tweeter
- controls Shape Switch, Bright Switch, Gain Level, Bass, Middle, Treble, Hue, Master Volume, Tweeter Switch, Auto-comp w/LED
- i/o's Input, CD / MP3 Input, Line Out, Effects Loop, Headphones
- cabinet Sealed Back Bass Reflection Cabinet w/Tilt-Up System
- size 422(W) x 632(H) x 312(D) (mm)
- weight 18.8kg



## SWX35 35W Bass Amplifier

- output power 35Watts
- speaker unit 10" Coaxial 2Way Bass speaker
- controls Shape Switch, Bright Switch, Gain Level, Bass, Middle, Treble, Hue, Master Volume, Auto-comp w/LED
- i/o's Input, CD / MP3 Input, Line Out, Headphones
- cabinet Sealed Back Cabinet w/Tilt-Up System
- size 378(W) x 532(H) x 312(D) (mm)
- weight 14.2kg



## SWX20 20W Bass Amplifier

- output power 20Watts
- speaker unit 8" Coaxial 2Way Bass Speaker
- controls Shape Switch, Bright Switch, Gain Level, Bass, Middle, Treble, Hue, Auto-comp
- i/o's Input, CD / MP3 Input, Headphones
- cabinet Sealed Back Cabinet
- size 337(W) x 410(H) x 240(D) (mm)
- weight 8.6kg



# X Tone Blaster

## IS412CA/IS412CS

Speaker Unit

- speaker unit 4 x 12" Ibanez IS1216G
- power handling 320Wrms/640Wmax
- i/o's 2 x Input (40&160)
- cabinet IS412CA: Traditional Angled  
IS412CS: Straight Front Angled
- size 707 (W) x 755 (H) x 334 (D) mm (with casters)
- weight 34kg (with casters)

The new generation Tone Blaster X series amps were designed and created to answer the needs of today's guitarist. The parametric mid EQ allows you to dial in any tone you're looking for in an instant. The exclusive X mode allows you to

get monstrously heavy and lets you cut through the din of the loudest rhythm section. The gain control in the normal channel can be dialed down to give you anything from a clean jazz tone to a crunchy, slightly overdriven rock'n roll tone. Plug in and express yourself with TBX.

### Front Panel (TBX150H)



#### Gain control on Normal Channel

The TBX features a Gain control on the Normal Channel to offer wider tonal variation ranging from pure clean tones to crunchy overdrive.

#### X Mode (X Channel)

The X mode/channel emphasizes tighter low end and a unique tonality in the midrange, which increases sustain and harmonics.

#### Parametric MID EQ control

Mid range is a very important aspect in determining the character of an amplifier's sound. The TBX active Parametric Mid control allows you to shape a wide variety of distortion tones and amp sounds. This control also works for the Normal channel on the TBX15R and TBX30R.

#### HUE Control

Adjusts overall tonal character. (TBX150H/150R)



### TBX150H

150W Guitar Amplifier

- output power 150W@4Ω
- controls Normal Channel - Overdrive Switch, Gain, Bass, Middle, Treble, Volume, Reverb Level  
Hot Channel - X Mode Switch, Gain, Bass, Middle Frequency, Middle Level, Treble, Volume, Reverb Level, Channel Switch, Hue Input, Send, Return, 2 x Speaker Output, Footswitch 1 & 2
- i/o's
- cabinet W/Accessory Box
- size 636 (W) x 259 (H) x 252 (D) (mm)
- weight 14.1kg



### TBX150R

150W Guitar Amplifier

- output power 150W@4Ω
- speaker unit 2 x 12" Ibanez IS1208G
- controls Normal Channel - Overdrive Switch, Gain, Bass, Middle, Treble, Volume, Reverb Level  
Hot Channel - X Mode Switch, Gain, Bass, Middle Frequency, Middle Level, Treble, Volume, Reverb Level, Channel Switch, Hue Input, Send, Return, Speaker Output, Footswitch 1 & 2
- i/o's
- cabinet Closed Back Cabinet
- size 668 (W) x 500 (H) x 274 (D) (mm)
- weight 24.9kg



### TBX15R

15W Guitar Amplifier

- output power 15W@4Ω
- speaker unit 8" Ibanez IS804
- controls Normal Channel: Gain, Volume, Channel Switch  
X Channel: Gain, Volume  
EQ: Bass, Middle Frequency  
Middle Level, Treble, Reverb Level  
Input, CD/MP3 In, Headphones  
Closed Back Cabinet
- i/o's
- cabinet
- size 367 (W) x 351 (H) x 201 (D) (mm)
- weight 7.3kg



### TBX30R

30W Guitar Amplifier

- output power 30W@8Ω
- speaker unit 10" Ibanez IS1008G
- controls Normal Channel: Gain, Volume, Channel Switch  
X Channel: Gain, Volume  
EQ: Bass, Middle Frequency  
Middle Level, Treble, Reverb Level  
Input, CD/MP3 In, Footswitch, Headphones  
Open Back Cabinet
- i/o's
- cabinet
- size 440 (W) x 413 (H) x 222 (D) (mm)
- weight 8.3kg



### TBX65R

65W Guitar Amplifier

- output power 65W@4Ω
- speaker unit 12" Ibanez IS1204G
- controls Normal Channel: Overdrive Switch, Gain, Bass, Middle, Treble, Volume, Channel Switch  
Hot Channel: X Mode Switch, Gain, Bass, Middle Frequency, Middle Level, Treble, Volume, Reverb Level  
Input, CD/MP3 In, Footswitch, Headphones  
Closed Back Cabinet
- i/o's
- cabinet
- size 491 (W) x 451 (H) x 254 (D) (mm)
- weight 17.7kg



#### IS Speaker driver

Extremely efficient Ibanez IS speaker drivers are voiced for tight and focused low-end for today's modern music styles.



#### IFS2X

Footswitch Controller

Latching footswitch with metal housing for use with the TBX30R, TBX65R and T35.



#### IFS4X

Footswitch Controller

Latching 4-button footswitch with metal housing for use with the TBX150H/TBX150R.

# MIMX

**T**raditional companies provide versatility and warm vintage tones with their modeling amps, but only Ibanez brings you the same versatility plus the heavy, searing modern tones required by today's players. The MIMX amps offer a wider variety of distortion and overdrive than any other modeling amp currently available, and there's still plenty of classic and clean tones to get you through any gig.



## MIMX150H 150W Fully Digital Modeling Head

- 150 watt @ 4 ohms
- Fully digital programmable preamp with
  - 11 amp models
  - 10 memory locations
  - 50 rhythm patterns
  - 13 digital effects
- Accessory compartment
- 636(W) x 259(H) x 252(D) (mm)
- Weight: 13.9kg



## MIMX65 65W Fully Digital Modeling Combo

- 65 watt guitar amp
- 12" Ibanez 51204G speaker
- Fully digital programmable preamp with
  - 11 amp models
  - 10 memory locations
  - 50 rhythm patterns
  - 13 digital effects
  - Chromatic Tuner
- 1/4" CD/MP3 input jack
- 1/4" headphones/record out jack
- Closed-back cabinet design
- 491(W) x 451(H) x 254(D) (mm)
- Weight: 16.2kg



## IFC2 Effects Foot Controller

The PEDAL FX section is ONLY accessible using the optional Ibanez IFC2 Foot Controller for MIMX150H/MIMX65. (The IFC2 is not included and is sold separately)



## MIMX30 30W Fully Digital Modeling Combo

- 30 watt guitar amp
- 10" Ibanez 51008G speaker
- Fully digital programmable preamp with
  - 11 amp models
  - 4 memory locations
  - 26 rhythm patterns
  - 18 digital effects
  - E-note Tuner
- 1/4" CD/MP3 input jack
- 1/4" headphones/record out jack
- 442(W) x 409(H) x 220(D) (mm)
- Weight: 8.8kg



## IFS2M Pedal Switch

The PEDAL FX section is ONLY accessible using the optional Ibanez IFS2M Foot Controller for MIMX30. (The IFS2M is not included and is sold separately)

### Amp Selections (MIMX150H/MIMX65/MIMX30)

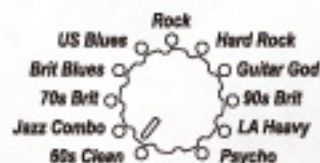

#### AMP SELECTION

11 amp models with the widest amp/tonal type variation available. Features ten of the classic British, American and boutique amp models plus a new and original Ibanez high-gain "Psycho" model.

### Digital Effects

**MIMX150H/MIMX65** 13 digital effects (up to three effects simultaneously)

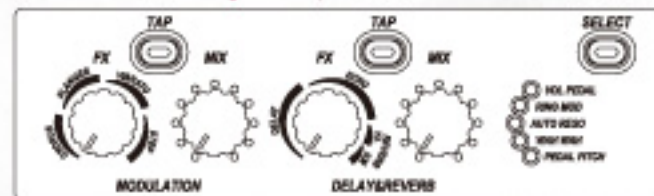

**MIMX30** 18 digital effects (up to three simultaneously)

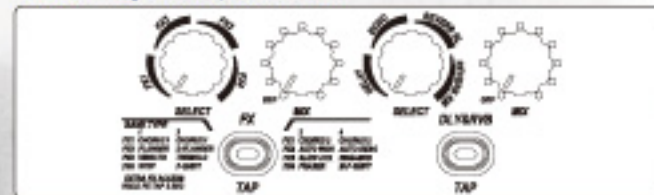

### Programable Patches

Any combination of settings can be auditioned and adjusted in real time and then saved to MIMX memory locations. This includes amp model, equalization setting and digital effects and their particular parameters.

**MIMX150H/MIMX65** 10 factory Presets (over-writable)  
10 user programs

**MIMX30** 4 factory Presets (over-writable)  
4 user programs

### Rhythm Patterns

Wide range of rhythms for any kinds of practice, recording or single gig: metal, Latin, hip-hop, ballad, shuffle, hard rock and much more.

**MIMX150H/MIMX65** 50 patterns Rhythm Machine

**MIMX30** 26 patterns Rhythm Machine

# Thermion

**T**he 120-watt Thermion features only the finest top-shelf, military-grade components...all in the service of a design that considers every aspect of modern playing from tone to transport. But the most important spec is this: Thermion is all-tube. There is absolutely no solid-state circuitry in the signal path. So you've got the tones, power and control you need to conquer every album track, every stage, every city, and ultimately, the entire universe (admittedly, that may take a little time).

## TN120 THERMION™ Ibanez All-Tube Amplifier

- 120W 5%THD @ 4, 8, or 16 ohms
- All tube signal line circuitry (NO SOLID-STATE) with mechanical relays
- 4 x 6L6GC/MSTR MATCHED Ruby Tubes™ output tubes (user switchable to 6550s)
- 5 x 12AX7A-SELECTED Ruby Tubes™ preamp tubes
- HI/LO input impedance switch
- Two independent channels: Vintage Channel & Hot Channel
- Tube circuit Effects Loop w/Send and Return Level Control on the front panel and Blend/Serial switch on the rear panel.
- Illuminated front panel and illuminated Ibanez logo
- Dampening switch enables different distortion characteristics out of Hot channel
- Rotary 3-position Bright switch in Vintage channel
- Traditional passive EQ in both channels
- 3-button footswitch for Channel switching, Dampening and Effects Loop on/off
- Maintenance friendly, professional-grade design includes bias adjustment interface for output tube replacement on top of chassis, IEC 60065 compliance, high efficiency toroidal core transformer with automatically resetting thermal fuse, durable 3/4" plywood cabinet, heavy-duty toggle switches, potentiometers with dust-covers, and more.
- Size: 740 (W) x 290 (H) x 260 (D)
- Weight: 24kg

## TN412A THERMION™ Traditional Angled Guitar Speaker Cabinet TN412S THERMION™ Straight Front Angled Guitar Speaker Cabinet

- 4 x Celestion® Vintage 30™ speaker drivers
- 5/8" birch plywood provides durability and augments resonance
- Input jacks w/stereo/mono switch
- Separate left and right chambers eliminate acoustic interference
- 2-1/2" large heavy-duty pop-in casters
- Durable 1.5mm black nickel-plated carbon steel corners and additional front angle corners (TN412A)
- Ultra-durable cone net grill
- Size: 778 (W) x 750 (H) x 366 (D)
- Weight: 50kg

\* "RUBY Tube" is a trademark of the Magic Parts Co. \*\* "Celestion" and "Vintage 30" are trademarks of the Celestion Corp.

TN120

TN412A

TN412S



## AMPLIFIERS



### VBG-"ValBee" Valve sound in a compact package.

- output power 5W @ 4Q Tube Guitar Amp  
1 x 6L6GC (Power), 1 x 12AX7 (Pre)
- speaker unit 6.5" Speaker
- controls Gain, Bass, Middle, Treble, Presence, Volume, Boost SW
- i/o's Guitar Input, Valve Powered Phones/Rec Out, Send, Return
- cabinet Closed-Back Cabinet
- size 300(W) x 280(H) x 240(D) (mm)
- weight 7.8 kg



### IBZ10G GUITAR AMPLIFIER

- output power 10W @ 8Q
- speaker unit 6.5" speaker
- controls Overdrive On/Off Switch, Gain, Bass, Middle, Treble, Volume
- cabinet Guitar Input, Headphone, CD Input
- size Closed-Back cabinet
- size 274(W) x 313(H) x 200(D) (mm)
- weight 5.3 kg



### IBZ10B BASS AMPLIFIER

- output power 10W @ 8Q
- speaker unit 6.5" speaker
- controls Bass, Middle, Treble, Presence, Volume
- cabinet Bass Input, Headphone
- size Closed-Back cabinet for "phat" bass tone
- size 280 (W) x 310 (H) x 205 (D) (mm)
- weight 5.1 kg

# TROUBADOUR

## ACOUSTIC GUITAR AMPLIFIER

What's the one thing that almost all small venue musicians strive for when it comes to amplifiers? Some might say "pure immersive tone", which would undoubtedly be followed by "portability". The new Ibanez Troubadour series Acoustic Guitar Amplifiers deliver exactly that, along with the striking appearance of a hand-crafted boutique amplifier. Whether you're strumming away at the local coffee shop or playing weekly gigs at a religious venue, the sounds of the new Troubadour will fill the room. Plus, you won't have to break your back getting your amp in and out. The Ibanez Troubadour was designed with portability in mind.



T10	10W Acoustic Guitar Amplifier	T20	20W Acoustic Guitar Amplifier	T35	35W Acoustic Guitar Amplifier
<ul style="list-style-type: none"> <li>output power</li> <li>speaker unit</li> <li>controls</li> <li>i/o's</li> <li>cabinet</li> <li>size</li> <li>weight</li> </ul>	<ul style="list-style-type: none"> <li>10 w</li> <li>6.5" Speaker</li> <li>Mid Shape, Hue</li> <li>Chorus w/Speed Control</li> <li>Internal Limiter, Volume</li> <li>Guitar Input, CD/AUX Input</li> <li>Headphones/Line Out</li> <li>Closed Back Cabinet w/Tilt-up System</li> <li>205(W) x 258(H) x 195(D) (mm)</li> <li>3.4kg</li> </ul>	<ul style="list-style-type: none"> <li>output power</li> <li>speaker unit</li> <li>controls</li> <li>i/o's</li> <li>cabinet</li> <li>size</li> <li>weight</li> </ul>	<ul style="list-style-type: none"> <li>20 w</li> <li>8" Coaxial Speaker (with tweeter)</li> <li>3 Band Eq w/Sweepable Mid</li> <li>Natural Mode/Shaped Mode</li> <li>Chorus w/Speed Control, Reverb,</li> <li>Internal Limiter, Mic Channel w/Tone Control</li> <li>Mic Volume, Guitar Volume, Master Volume</li> <li>Guitar Input, Microphone Input (XLR)</li> <li>CD/AUX Input, Headphones/Line Out</li> <li>Sealed Back Cabinet w/Tilt-up System</li> <li>267(W) x 318(H) x 241(D) (mm)</li> <li>6.6kg</li> </ul>	<ul style="list-style-type: none"> <li>output power</li> <li>speaker unit</li> <li>controls</li> <li>i/o's</li> <li>cabinet</li> <li>size</li> <li>weight</li> </ul>	<ul style="list-style-type: none"> <li>35 w</li> <li>10" Coaxial Speaker (with tweeter)</li> <li>3 Band Eq w/Sweepable Mid</li> <li>Natural Mode/Shaped Mode Switch</li> <li>Chorus w/Depth &amp; Speed Control, Reverb</li> <li>Internal Limiter, Mic Channel w/Tone Control</li> <li>Mic Volume, Guitar Volume, Master Volume</li> <li>Guitar Input, Microphone Input (XLR)</li> <li>CD/AUX Input, Headphones Out, Stereo Balanced Line Out, Foot Switch Jack (Chorus/Reverb)</li> <li>Ported Bass Reflection Cabinet w/Tilt-up System</li> <li>325(W) x 396(H) x 304(D) (mm)</li> <li>10.5kg</li> </ul>



### Dual "MODE" Switch

The natural mode produces rich, warm acoustic sounds with shimmering overtones perfect for fingerstyle playing. The shaped mode scoops the mids, producing an open sound with a tight bottom end for strumming styles.



### Chorus

All Troubadour Series Amplifiers feature chorus with soft natural mids and crystal clear highs.



### Mic Input

The mic input features a totally independent mic preamp, so it won't be colored by any effects going through the guitar side. It also features independent tone and volume controls.

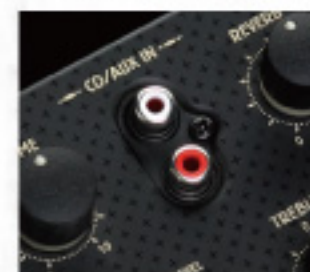

### CD/AUX Input

The included aux input allows you to play along with a connected MP3 or CD player, great for bedroom jam sessions or rigorous woodshedding.

# Jemini distortion



## JEMINI - Steve Vai Signature Distortion Pedal

After developing so many guitars with Steve Vai, the long wait for this pedal has all been worth it. All aspects of the JEMINI are expressions of him, as are his axes. With the multi-colored die-cast casing, two identical distortions are built in for a variety of sonic occasions, and the unique large LEDs tell you they are in operation not only on a dark stage, but even under the daylight. Not just a new distortion pedal, the Ibanez JEMINI powers you and your axe up as it does Steve and his guitars.

### LED Lit Controls

Each side includes drive, tone and level controls with LED indicators around each control and the LED brightness control switch for daytime use or saving the battery.

### Steve Vai Signature Foot Pedals

Steve's trademark logo is imprinted on the Jemini's foot switches.

### Heavy Duty Aluminum Housing

The housing is finished off with Steve's infamous trademark owl palm job.

# TONE-LOK

EFFECTS PEDALS

On the inside, Tone-Lok pedals feature hi-fidelity components carefully tweaked with the constant input from a new generation of Ibanez players. And all this great stuff comes encased in cool looking, road tough metal boxes at prices the working player can afford.

On the outside, Tone-Lok effects are equipped with our exclusive "set and forget" Push-Lok rotary pots. Push the knobs down and your tone settings lock securely inside the case. No more lost settings or knobs broken.



### AP7 Analog Phaser

The addition of the AP7 to the Tone-Lok series has brought with it the warm midrange sounds of a true Analog Phaser. The pedal features speed, depth, and feedback controls as well as a 3-way switchable phase circuit. When switched to 4-stage phasing, the pedal recreates the sounds of a vintage phaser. When switched to 2-stage phasing, the pedal produces more aggressive and deep phasing characteristic of modern pedals. This setting works best on more distorted lead sounds.



### TC7 Tri-Mode Chorus

Are you bored with normal chorus pedals? If so, the new Ibanez TC7 will bring the thrill back. The TC7 can create three types of chorus with the combination of two individual chorus circuits. It truly expands your guitar's expressiveness.



### SM7 Smash Box

The Smashbox is the most aggressive weapon in the Tone-Lok distortion arsenal. Armed with obscene amounts of gain, tight low end, and searing highs, the Smashbox is THE heavy rock sound for the contemporary guitarist. Special "VIB" noise gate and "EDGE" (sharp/smooth) controls let you handle anything from all-out shred to machine-gun metal riffs and rhythms.



### SH7 7th Heaven

Designed specifically for 7-string guitars with the input from some of Ibanez's hottest 7-string players, the SH7 Seventh Heaven distortion pedal accentuates the low-end girth of the 7-string while reducing unwanted string noise. A special mode switch allows you to choose between two different distortion voicings: while Lo, Hi, Drive, and Level knobs give you total tone control. An absolute reax-hax effect for replicating the best 7-string sounds of others or creating your own individual tones.



### DS7 Distortion

The most versatile Ibanez distortion pedal ever, capable of producing a wide range of smooth, dynamic overdrive tones, from a subtle tonal nudge to wailing rock'n'roll crunch, the DS7 delivers days of sustain and gobs of gain.



### TS7 Tubescreamer

The Tubescreamer isn't just a stamper, it's an institution. Our latest generation Tubescreamer, the TS7, is no exception. With the Tubescreamer's classic subtle-but-smooth overdrive, the TS7 expands the expressiveness of your guitar while maintaining its tonal integrity. Tone adjustments are provided by the classic three knob configuration with an added "hot" switch for an extra gain boost.



### FZ7 Fuzz

For out-kcomplete 60's feedback with none of the drawbacks, the FZ7 is the ultimate in psychedelic fuzz. With the FZ7's tone, drive, and level controls, it's never been easier to get the right retro tones. You can even engage the DAMAGE switch for that ratty, broken speaker sound. Yeah, baby, yeah! Dial in, tune up, drop down or whatever turns you on.



### DE7 Delay/Echo

Add new dimensions to your sound with the DE7 Delay/Echo pedal. Get the best of both worlds: high tech digital sounds comparable to expensive rack units or warm vintage tape echo sounds—all with a simple flick of the switch. TIME, REPEAT and LEVEL controls help you dial in just the right amount of delay, while stereo outputs can be used for a more spacious sound. With a range of 30ms to 2.6 seconds, the DE7 is the only sound solution for every playing situation.



### PH7 Phaser

Designed to emulate the effect of a rotating speaker, the PH7 has a switchable phase circuit capable of either four or eight stages of smooth phasing. With these two very different tonal modes, you can go from a subtle shimmer to all-out 70's "let's get funky" phasing.



### PM7 Phase Modulator

If you've gone through one phase after another, maybe it's time for the final phase. The PM7 Phase Modulator offers three types of waveforms to give you everything from classic phaser to EI effects to top say gun sounds. Since good things come in threes, the PM7 also has three phase stages: vintage, deep and dry, and deep and pronounced. With some minor tweaking, the PM7 goes from traditional to 21st century and beyond.



### AW7 Autowah

There are autowahs. And there are autowahs. But the Tone-Lok AW7 isn't just any autowah. It's got standard wah where both the highs and lows are out and it's got a wah setting where only the highs are out. And it's got distortion. Band Pass Filter provides the sound of a standard wah pedal left at one setting (a favorite wah pedal technique of Joe Satriani). You can even change the chain order of the effects to get different tones: either distortion to wah or wah to distortion.



### LF7 Lo Fi

The first dedicated filter pedal for the guitar, the LF7's voltage controlled analog high and low pass filters allow you to emulate transistor radio and reverb-type sounds. Best used at the end of a signal chain in combination with other pedals, this tidling new bomb creates wide soundscapes of far out tones that previously required a massive rack of analog electronics. The Lo Fi also performs equally well with rock, drum machines or in any "sea-devils" context.



### PD7 Flat-Hed Bass Overdrive

Why let guitarists rule the stage? Loaded with growling low-end distortion, the PD7 levels the playing field for the rock bassist. The PD7 is armed with three pre-amp style voicings and an attack control switch, which accents the amount of harmonic content in your sound. With DRIVE, LO, HI, and LEVEL knobs, dialing in a thunderous bass sound has never been easier.



### SB7 Synthesizer Bass

If you're looking for new tones or you're still soldering with resentment against synth bass keyboard players, the SB7 is the ticket. You've got real low feel—in other words no annoying tracking errors and delays. You can envelop chords.

# TUBE KING DISTORTION



## TK999HT Tube Distortion

When it comes to genuine tube distortion in a stomp box, the Tube King TK999HT rules. Featuring an actual 12AX7 tube, 3 band EQ/D tone controls along with Presence switch, the Tube King generates a wide variety of tones, including thick, singing distortion and outrageous heavy metal distortion. Also with its unique VXD function, it eliminates the noise and helps to create sharp rhythmic expression with heavy distortion. Housed in a unique shaped rigid die-cast case with visible tube through the transparent window, the Tube King will reign forever.



## WD7 Weeping Demon

The most variable and controllable guitar wah you can get. The Weeping Demon's shrieks, cries, wails and seductive siren songs will have your audience screaming for more. The Weeping Demon features spring and normal footboard action, selectable wah range, fine tuning controls and more.



### Mode Lever

Changes the mode so the effect can be turned on and off with the FOOTSWITCH or with the AUTO SWITCH (effect turns off when pedal is in the upright position). A1: AUTO SWITCH Mode A2: FOOTSWITCH Mode



### Auto-Off Delay

In the AUTO SWITCH mode, you can set the effect-off either as a standard instant-off when the pedal is returned to the full up-right position or a delayed-off by turning the control clockwise.



### Footswitch

Allows on-off switching of the effect independent of the footboard when the MODE LEVER is in the FOOTSWITCH mode.

# TS808 & 9 series

When it comes to compact effects, nine is the magic number. There are sound reasons why, twenty-five years after they were first made, you still see these effects in players' rigs. If you missed out on getting one of these classics the first time around, it's time.



TS808 Tube Screamer

The TS808 reissue, described as "the Holy Grail of Tubescreamers", features the same famous standard square footswitch of the original and the even more famous warm tones of the JRC 4558 chip used in most of the original TS808s. Ignore any over-the-counter look-alikes. If your tone is suffering from a lack of real warmth, the TS808 is the real, non-generic prescription.



TS9 Tube Screamer

The warmth of tube amps has been the goal for most of the over-drive pedals that exist. However, the Tube Screamer has been the choice 2nd to none by people searching for the best, because it lets the guitar sing so well in its original voice. The tone can be heard in playing by countless musicians over the years and still keeps fascinating new generations.



TS9DX Turbo Tube Screamer

"The Tube Screamer", TS9 had evolved on the same platform of TS9. The TS9DX offers three different settings for increased low end and crunch: +, Net, and Turbo, all of which maintain the original TS9's all integrity.



FL9 Flanger

After more than a decade of digital, analog pedals made a quiet come back, because guitar players don't always equate fidelity with quality. Having said that, the Ibanez FL9 has eliminated the unnecessary clock noise and provides a wide range of flanging effects with the 4 practical knobs, including the delay time.



CS9 Stereo Chorus

Advances in technology sometimes declare gear obsolete in disregard of existing demand. The Ibanez CS9 features the sought out BBD IC to replicate the original chorus effect with the two simple controls. Stereo outputs enable creation of an indefinite sound space by using two amps.



AD9 Analog Delay

Analog delay was the hot topic in the music industry when it was first introduced. It changed the whole effort to obtain echo sound into just switching and turning knobs. And nowadays everyone has access to the effect, with much more exact repeat sounds due to digital technology. However, the warmth of analog delay has many adherents that will never be satisfied with its digital counterpart.



DC3&DC5 Splitter cords for powering 3 or 5 pedals from one adapter.



AC109 Standard 9-volt 200mA regulated adapter for Ibanez compact effects.

# Tuners

When you make 6-string, 7-string and 8-string guitars for players who use all kinds of alternate tunings, you'd better

be very serious about tuning. We are. Our wide variety compact tuners offer strict accuracy, easy operation and our famous Ibanez reliability.

## Clip Tuner

Both Ibanez clip tuners, new PU20 and PU10, are designed to tune electric and acoustic guitars, basses, violins, banjos, mandolins, and more without interference from ambient room noise. It does it all without the use of mics, microphones or pickups. Tuning in noisy environments is a snap because the unique, flexible clamp actually feels the instrument's vibration instead of relying on sound. PU20 features backlit large LCD display for maximum visibility even in the dark stage. PU10 features the 4 hinges that allow a perfect view of the tuner's LED display from nearly any angle.

\* Black and Silver colors are available in PU10.



PU20

PU10 SL

PU10



RU10

RU10 WH

RU10 RD

RU10

Jam Tuner

There is no doubt that tuning is important. However it is just preparation, when your goal is to be playing guitar and having fun. With the Ibanez RU10, Jam Tuner, you can do both without firing up your amp. Besides functioning as a chromatic tuner, the RU10 combines a metronome and the Rhythm Play function that features preset rhythm patterns to play along with. The gain control enables you to produce an amazing, real deal distortion sound out of the built-in speaker, letting you jam right away.

## LU20

### Pedal Tuner

This tuner features a durable diecast housing and LED display with a three-color indicator for maximum visibility from the floor. It also features a true bypass on/off switch for the truest tone and a muting function.



LU20

LU20 BK



LU10 Chromatic Tuner

Wide-size easy-to-read chromatic LED tones.



GU40 BL

GU40 RD

GU40 SL

CU40

MU40

Automatic and manual guitar/bass tuner

Chromatic tuner

Chromatic tuner & metronome

# Cables

## Series 96

- 96 micro-strands of silver plated copper core wires offer low impedance and maximum signal transfer.
- Case: 0.1 x 96 (Silver Plated)
- Shield (Braid): 0.1 x 8 x 12 (99.99%)
- Secure Grip Rubber on Plug
- Velcro Strap with Ibanez Logo equipped
- Outer Jacket: PVC, Woven



## Series DS

- Double-shielded construction offers pro-quality and durability at standard cable prices.
- Case: OFC (99.99%)
- Shield: OFC (99.99%) Braided and Aluminum Sheet
- Velcro Strap with Ibanez Logo equipped
- Outer Jacket: PVC, Woven (Black, Red & Blue colors are available)



## Series STC



## Microphone Cables

- Case: OFC (99.99%)
- Shield (Braid): 0.12 x 64
- Velcro Strap with Ibanez Logo equipped
- Plug Type: 1/4" XLR
- Length: 3.05m (10ft), 6.10m (20ft), 15.24m (50ft)



## Speaker Cables

- Case: 0.1 x 200 (Silver Plated) x 2
- Shield: Braided
- Velcro Strap with Ibanez Logo equipped
- Plug Type: 1/4" Neutrik® Speaker
- Length: 1.83m (6ft), 3.05m (10ft), 7.63m (25ft), 15.24m (50ft)



## GUITAR INSTRUMENT CABLE — SERIES 96

Length	Plug Type	Model No.	
6ft/1.83m	Straight-Straight	NS56	
	Straight-Right Angle	NS56L	
10ft/3.05m	Straight-Straight	NSC10BK	Woven (Black)
	Straight-Right Angle	NSC10L	
15ft/4.58m	Straight-Straight	NSC15	
	Straight-Right Angle	NSC15L	
20ft/6.10m	Straight-Straight	NSC20BK	Woven (Black)
	Straight-Right Angle	NSC20L	
0.5ft/15cm	Right Angle-Right Angle	NSC05LL	Patch Cable
	Right Angle-Right Angle	NSC05RL	Patch Cable

## GUITAR INSTRUMENT CABLE — SERIES DS

Length	Plug Type	Model No.	
6ft/1.83m	Straight-Straight	DSC6	
	Straight-Right Angle	DSC6L	
10ft/3.05m	Straight-Straight	DSC10RD	Woven (Red)
		DSC10BL	Woven (Blue)
		DSC10BK	Woven (Black)
	Straight-Right Angle	DSC10L	
		DSC10LL	
		DSC10L	
15ft/4.58m	Straight-Straight	DSC15	
		DSC15L	
		DSC15LL	
	Straight-Right Angle	DSC20RD	Woven (Red)
		DSC20BL	Woven (Blue)
		DSC20BK	Woven (Black)
20ft/6.10m	Straight-Straight	DSC20	
	Straight-Right Angle	DSC20L	
25ft/7.63m	Straight-Straight	DSC25	
	Straight-Right Angle	DSC25L	
0.5ft/15cm	Right Angle-Right Angle	DSC05LL	Patch Cable
	Right Angle-Right Angle	DSC05RL	Patch Cable

## GUITAR INSTRUMENT CABLE — SERIES STC

Length	Plug Type	Model No.	
6ft/1.83m	Straight-Straight	STC6	
10ft/3.05m	Straight-Straight	STC10	
	Straight-Right Angle	STC10L	
15ft/4.58m	Straight-Straight	STC15	
	Straight-Right Angle	STC15L	
20ft/6.10m	Straight-Straight	STC20	
	Straight-Right Angle	STC20L	
25ft/7.63m	Straight-Straight	STC25	
	Straight-Right Angle	STC25L	
0.5ft/15cm	Right Angle-Right Angle	STC05LL	Patch Cable
	Right Angle-Right Angle	STC05RL	Patch Cable

## MICROPHONE CABLES

Length	Plug Type	Model No.	
10ft/3.05m	XLR-XLR	MCCE10	
	XLR-1/4"	MCCE10	
20ft/6.10m	XLR-XLR	MCCE20	
	XLR-1/4"	MCCE20	
50ft/15.24m	XLR-XLR	MCCE50	
	XLR-1/4"	MCCE50	

## SPEAKER CABLES

Length	Plug Type	Model No.	
6ft/1.83m	NEUTRIK® NL4FX-NEUTRIK® NL4FX	SPCN6	
	1/4"-1/4"	SPCP6	
10ft/3.05m	NEUTRIK® NL4FX-NEUTRIK® NL4FX	SPCN10	
	1/4"-1/4"	SPCP10	
25ft/7.63m	NEUTRIK® NL4FX-NEUTRIK® NL4FX	SPCN25	
	1/4"-1/4"	SPCP25	
50ft/15.24m	NEUTRIK® NL4FX-NEUTRIK® NL4FX	SPCN50	
	1/4"-1/4"	SPCP50	

# Picks

Ibanez offers picks for just about every type of player with different feels, functions and looks. Function wise, the Grip Wizard series feature sand or rubber grips for superior gripping ability. Look wise, Ibanez offers a selection of

original metallic colors and other unique colors and designs. And then there is the signature line of picks that are exactly what the artists use in most cases. In fact, Steve Vai won't use anything but his signature Ibanez picks.

## Basic Color Series

Also, Ibanez covers the basic picks with orthodox shape color. You can choose from 6 kinds of shapes.



## Ibanez Classic Design Series

Three of Ibanez' legendary icons are now featured on picks — "Tipping Finger," "Tree of Life" and a new design defined the "Ibanez trademark."



## Grip Wizard Series Rubber Grip

Non-slip rubber softly fits your finger. Available on polycetal, or super hard PPS material picks.



## BASIC COLOR SERIES

Shape	Material	Thickness (mm)	Model No.	Available color
4	Celluloid	Heavy	CE4H	BL/PL/SH/WH
4	Celluloid	Medium	CE4M	BL/PL/SH/WH
4	Celluloid	Thin	CE4T	BL/PL/SH/WH
6	Celluloid	Heavy	CE6H	BL/SH/WH
6	Celluloid	Medium	CE6M	BL/SH/WH
14	Celluloid	Heavy	CE14H	BL/SH/WH
14	Celluloid	Medium	CE14M	BL/SH/WH
16	Celluloid	Heavy	CE16H	BL/SH/WH/MS/NSC/WH
16	Celluloid	Medium	CE16M	BL/SH/WH/MS/NSC/WH
20	Celluloid	Heavy	CE20H	BL/SH
20	Celluloid	Medium	CE20M	BL/SH
Thumb Pick	Celluloid		CE22L	PL

## IBANEZ CLASSIC DESIGN SERIES

Shape	Material	Thickness (mm)	Model No.	Available color
16	Celluloid	Heavy	TL16H	BL/BL/WH/MS/NSC/WH
16	Celluloid	Medium	TL16M	BL/BL/WH/MS/NSC/WH
16	Celluloid	Heavy	TI16H	BL/BL/WH/MS/NSC/WH
16	Celluloid	Medium	TI16M	BL/BL/WH/MS/NSC/WH
16	Celluloid	Heavy	BI16H	BL/BL/WH/MS/NSC/WH
16	Celluloid	Medium	BI16M	BL/BL/WH/MS/NSC/WH

## GRIP WIZARD SERIES

Shape	Material	Thickness (mm)	Model No.	Available color
16	Polycetal w/ Rubber Grip	Extra Heavy	PA16XR	BL/BL/WH
16	Polycetal w/ Rubber Grip	Heavy	PA16HR	BL/BL/WH
16	Polycetal w/ Rubber Grip	Medium	PA16MR	BL/BL/WH
16	Polycetal w/ Sand Grip	Extra Heavy	PA16XS	BL/BL/WH
16	Polycetal w/ Sand Grip	Heavy	PA16HS	BL/BL/WH
16	Polycetal w/ Sand Grip	Medium	PA16MS	BL/BL/WH
8	PPS w/ Rubber Grip	Heavy	PS8HR	BL
8	PPS w/ Rubber Grip	Medium	PS8MR	BL
17	PPS w/ Rubber Grip	Heavy	PS17HR	BL
17	PPS w/ Rubber Grip	Medium	PS17MR	BL
30	PPS w/ Rubber Grip	Extra Heavy	PS30XR	BL
30	PPS w/ Rubber Grip	Heavy	PS30HR	BL

## Signature Models

### Steve Vai

Here are the Vai's signature picks, and he won't use anything else.



## The Offspring

Be different. The Offspring picks feature the band symbol on one side, and the band name written in Japanese on the other.



## Paul Gilbert

This original shaped picks are what THE guitarist with style and speed need.



## Actual Size



# Bags

## Ultra-Deluxe Bags

Ultimate gig bag for players on the go. The new IGB701/IBB701 securely protects your instruments with extra pads from the body to the neck and with the bottom cover. These bags come with water-resistant exterior and extra-padded backpack straps.

### IGB701-BK

Bag for EL guitar

### IBB701-BK

Bag for EL bass

IGB701-BK

IBB701-BK

## Double Bags

Ibanez double gig bag lets you carry two instruments in one bag. With the wheel on the bottom, you can carry your guitars without any hassle.

### IDGB5-BK

Bag for EL guitar

### IDBB5-BK

Bag for EL bass

## Standard Bags

Even the most affordable bags have features to hold your instruments securely. Adjustable shoulder straps and easy-grip handle equipped.

### ISGB5-BK

Bag for EL guitar

### ISBB5-BK

Bag for EL bass

## Deluxe Bags w/Backpack

The GBP/BBP bags feature a detachable backpack. Not only is it handy for carrying accessories around along with your guitar or bass, it detaches for typical backpack use.

### GBP

Bag for EL guitar

### BBP

Bag for EL bass

GBP

BBP

Backpack

## Original Shape Bag

The genuine RG headstock-shaped gig bag protects your Ibanez guitar.

### IGH7

Bag for EL guitar

## Enamel Bags

This gig bag can not only protect your guitar, but it can also make a fashion statement. The new colored bags are made of glossy black enamel in two color options of orange or silver Ibanez logo to fit your own personal style.

### ISGE501-BKO

Bag for EL guitar

### ISGE501-BKS

Bag for EL guitar

ISGE501-BKO

ISGE501-BKS

# Cases

No matter which Ibanez guitar or bass you choose, you'll want to protect your precious investment. Do it in style with an authentic Ibanez hard shell case.

### W50RG

for RG, RG7, S, SA, SV (ind. 27" scale & left handed models)

### W50DNT

for DN

### W50SZR

for SZR

### W50BTB

for BTB, ATK, ITRB

### W50SR

for all of SR (ind. left handed models)

### M100C

for RG, RG7, S, SA (except 27" scale & left handed models)

### MB100C

for SR, SRX, EDB (except left handed models)

### AS-C

for AS

### GB-C

for AG, AGS

### AR-C

for GAX, AR, ART, ARX

### AFS-C

for AF, AFS, AK





# Finishes



