





時がどれ程経とうとも、  
どれほど時代が変わっても、「音楽」が絶えることはないと思う。  
決して鳴り止まないもの、それが音楽だと思う。

ならば、楽器はどうか。  
ひとつの楽器が変わることなく必ず在り続けるものだ、と言いきれるだろうか。

ギターやベースが音楽を奏でる楽器であり続けることを切に願い、  
それを実現することこそ、Ibanezの使命だと強く感じている。

# Electric Guitar

## TABLE OF CONTENTS

Electric Guitars .....	P.2
j.custom .....	P.4
Prestige .....	P.8
PREMIUM .....	P.18
IRON LABEL .....	P.22
RG .....	P.24
RGA / RGD .....	P.26
S .....	P.27
SA .....	P.28
FR / ARZ / X .....	P.29
Signature Model (Solid) .....	P.31
Hollow Body Guitars .....	P.40
Signature Model (Hollow) .....	P.45
Electric Bases .....	P.48
Acoustic Guitars .....	P.66
Amplifiers / Effects / Accessories .....	P.76



# *j. custom* Ibanez

—厳選された材料を使用し、日本屈指の熟練クラフトマンが組み上げる  
—常に高いプレイアビリティと優れたサウンドを追求する  
—それこそがIbanezの最高峰“j.custom”のコンセプト。

## Exclusive Specs.

- j.custom専用にシェイピングされたメイプル&ウォルナット5pc構造のネック
- 上質なヴェルベットの触感を目指したネックバックの“Velvetouch”フィニッシュ
- ハイ・フレットの高い演奏性を追及した“j.custom All Access”ジョイント・ヒール加工
- フレット・エッジの球面カスタム・トリートメント

### RG7570Z / RG8570Z / RG8571

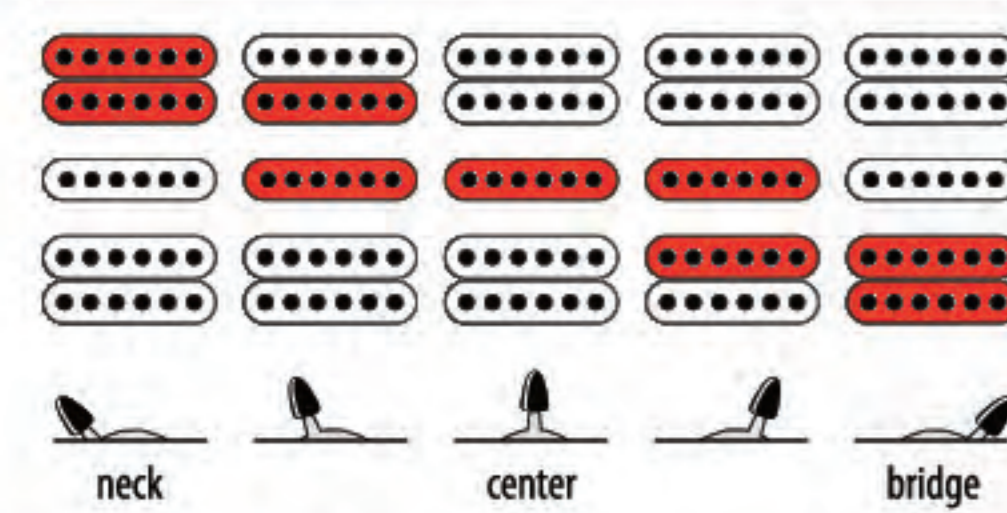

### RG8420ZD / RG8527Z

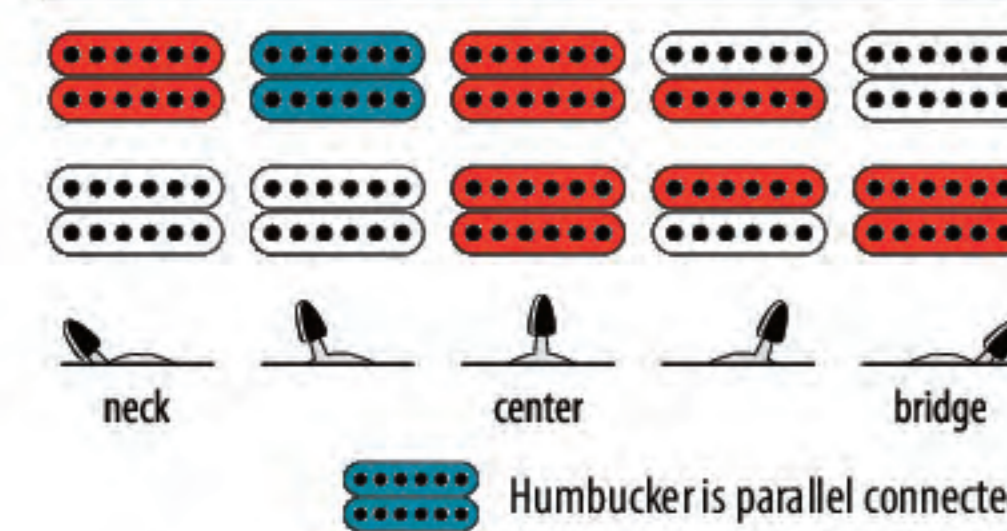

### RG8540ZD

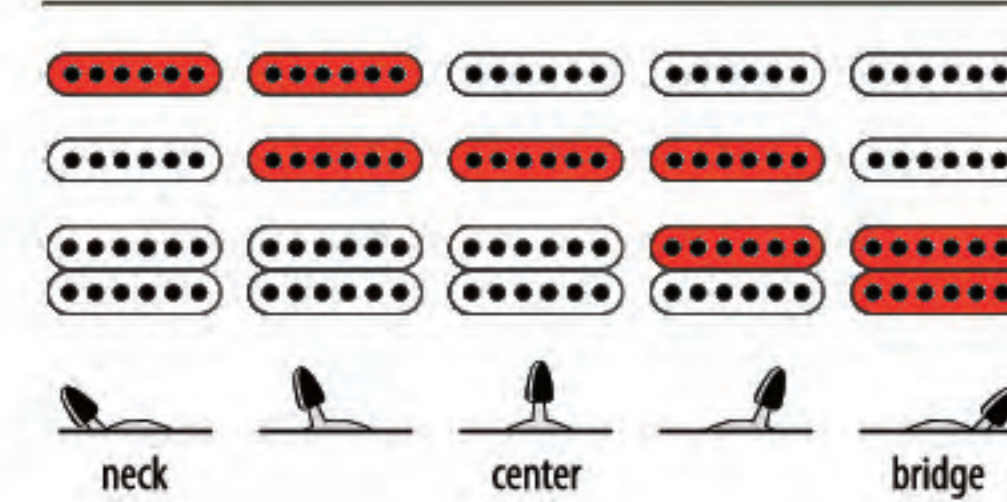

### RG j.custom control

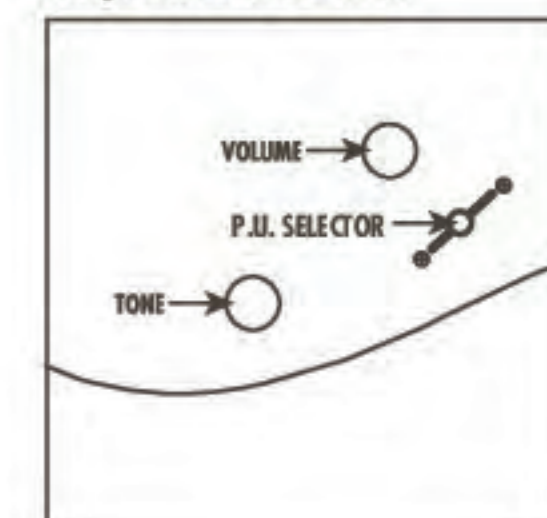



## NEW MODEL



**BBE**  
(Bright Brown Rutile)

**RBS**  
(Royal Blue Sapphire)

¥320,250 (本体価格 ¥305,000)

**RG7570Z** **MADE IN JAPAN**

- 5pc Maple/Walnut RG j.custom U shape neck w/ KTS™ TITANIUM rods
- AAA Flamed Maple (4mm) top / American Basswood (40mm) back body
- Selected Ebony fretboard w/ Abalone Dot position inlay
- 25.5 inch Scale
- Edge-Zero tremolo bridge w/ ZPS3
- DiMarzio® Air Norton™ (H) neck PU
- DiMarzio® True Velvet™ Middle (S) middle PU
- DiMarzio® The Tone Zone® (H) bridge PU
- hardware color : Cosmo Black
- string : .009~.042 Round Wound (D'Addario:EXL120)
- color : BBE (Bright Brown Rutile)  
RBS (Royal Blue Sapphire)
- includes : Hardshell case



**BBE**  
(Bright Brown Rutile)

**BX**  
(Black Onyx)

**RS**  
(Red Spinel)

¥320,250 (本体価格 ¥305,000)

**RG8570Z** **MADE IN JAPAN**

- 5pc Maple/Walnut RG j.custom Super Wizard neck w/ KTS™ TITANIUM rods
- AAA Flamed Maple (4mm) top / African Mahogany (40mm) back body
- Selected Rosewood fretboard w/ Flamed Maple binding & Tree of Life position inlay
- 25.5 inch Scale
- Edge-Zero tremolo bridge w/ ZPS3
- DiMarzio® Air Norton™ (H) neck PU
- DiMarzio® True Velvet™ Middle (S) middle PU
- DiMarzio® The Tone Zone® (H) bridge PU
- hardware color : Cosmo Black
- string : .009~.042 Round Wound (D'Addario:EXL120)
- color : BBE (Bright Brown Rutile)  
BX (Black Onyx)  
RS (Red Spinel)
- includes : Hardshell case

## SPOT MODEL



**BX**  
(Black Onyx)

¥315,000 (本体価格 ¥300,000)

**RG8571** **MADE IN JAPAN**

- 5pc Maple/Walnut RG j.custom Super Wizard neck w/ KTS™ TITANIUM rods
- AAA Flamed Maple (4mm) top / African Mahogany (40mm) back body
- Selected Rosewood fretboard w/ Flamed Maple binding & Tree of Life position inlay
- 25.5 inch Scale
- Tight-End R bridge
- DiMarzio® Air Norton™ (H) neck PU
- DiMarzio® True Velvet™ Middle (S) middle PU
- DiMarzio® The Tone Zone® (H) bridge PU
- hardware color : Cosmo Black
- string : .009~.042 Round Wound (D'Addario:EXL120)
- color : BX (Black Onyx)
- includes : Hardshell case



**BX**  
(Black Onyx)

**DLL**  
(Dark Lapis Lazuli)

**RS**  
(Red Spinel)

¥320,250 (本体価格 ¥305,000)

**RG8420Z** **MADE IN JAPAN**

- 5pc Maple/Walnut RG j.custom Super Wizard neck w/ KTS™ TITANIUM rods
- AAA Flamed Maple (4mm) top / African Mahogany (40mm) back body
- Selected Rosewood fretboard w/ Flamed Maple binding & Tree of Life position inlay
- 25.5 inch Scale
- Edge-Zero tremolo bridge w/ ZPS3
- Seymour Duncan® Jazz Model™ (H) neck PU
- Seymour Duncan® Custom 5™ (H) bridge PU
- hardware color : Cosmo Black
- string : .009~.042 Round Wound (D'Addario:EXL120)
- color : BX (Black Onyx)  
DLL (Dark Lapis Lazuli)  
RS (Red Spinel)
- includes : Hardshell case



**BX**  
(Black Onyx)

**DLL**  
(Dark Lapis Lazuli)

¥346,500 (本体価格 ¥330,000)

**RG8540Z** **MADE IN JAPAN**

- 5pc Maple/Walnut RG j.custom Super Wizard neck w/ KTS™ TITANIUM rods
- AAA Flamed Maple (4mm) top / African Mahogany (40mm) back body
- Selected Rosewood fretboard w/ Flamed Maple binding & Tree of Life position inlay
- 25.5 inch Scale
- Edge-Zero tremolo bridge w/ ZPS3
- Seymour Duncan® Classic Stack® Plus (S) neck PU
- Seymour Duncan® Classic Stack® Plus (S) middle PU
- Seymour Duncan® Custom 5™ (H) bridge PU
- hardware color : Chrome
- string : .009~.042 Round Wound (D'Addario:EXL120)
- color : BX (Black Onyx)  
DLL (Dark Lapis Lazuli)
- includes : Hardshell case

## 7-STRING



**BX**  
(Black Onyx)

¥336,000 (本体価格 ¥320,000)

**RG8527Z** **MADE IN JAPAN**

- 5pc Maple/Wenge RG-7 j.custom neck w/ KTS™ TITANIUM rods
- AAA Flamed Maple (4mm) top / African Mahogany (40mm) back body
- Selected Rosewood fretboard w/ Flamed Maple binding & Tree of Life position inlay
- 25.5 inch Scale
- Edge-Zero 7 tremolo bridge w/ ZPS3
- DiMarzio® PAF® 7 (H) neck PU
- DiMarzio® PAF® 7 (H) bridge PU
- hardware color : Cosmo Black
- string : .009~.054 Round Wound (D'Addario:EXL120-7)
- color : BX (Black Onyx)
- includes : Hardshell case



# Prestige



緻密に作り上げられ、高性能・高機能であり、さらには優れたプレイアビリティを備えていること。実践機に必要なそれら要素を全て備え、Made in Japanで完成される、Ibanez Prestige。

### Exclusive Specs.

- Prestige専用ハイ・パフォーマンス(HP)ネック・シェイプ
- スリッ軽減ラバーを装着し落下防止機構を備えた高機能“Collet Knob”
- 弾き易さを追求し、なめらかに仕上げた指板エッジ“Prestige Treatment”

## Precision, Performance, Playability

EVERYTHING YOU'VE EVER DREAMED OF IN A GUITAR OR BASS



### Edge-Zero Tremolo Bridge

ナイフエッジ支点構造、差し込み式のアームといった特徴を持つIbanez 伝統のトレモロ・ブリッジ“Edge”のコンセプトを受け継いだ“Edge-Zero”トレモロ・ブリッジ。



### SynchroniZR Tremolo Bridge

ボールベアリングによるスムーズなアクションと高剛性を実現したノンロックンク方式ゼロ・レジスタンス(ZR)・シンクロナイザー(SynchroniZR)・トレモロ・ブリッジ。



### ZR-2 Tremolo Bridge

ダブル・ロックンク・トレモロの常識をくつがえす、ZR-2(ゼロ・レジスタンス-2)トレモロ・ブリッジ。支点部に高精度のボール・ベアリングを採用し、従来のナイフ・エッジ方式とは異なるスムーズなアクションと操作性、そして高いチューニング精度を実現。



### Tight-End R Bridge / Tight-End Bridge

がっちりサドルが固定されたベースプレートとボディがフルコンタクトする事で、弦振動をロス無く伝えるハード・テイル・ブリッジ。ブリッジに手を置いて演奏する際のストレス低減のために上面がフラットで滑らかなよう設計されており、優れた演奏性を誇る。



### Zero Point System (ZPS3, ZPS3Fe, ZPS2)

通常のスプリングに加え、アディショナル・スプリング2本とストップ・ロッドをもつゼロ・ポイント・システム。トレモロ・ユニットを常にセンター位置(Zero Point)に保とうとする働きを持ち、弦の張力の変化を低減し安定した環境を実現。



### FX Edge III Bridge

ダブル・ロックンク構造を採用したフィクスト・ブリッジ「FX Edge III」。チューニング安定性とロング・サスティーンを確保。



### Tool

Prestige モデルのメンテナンスに最適なマルチ・ツール・キット付属。各サイズのレンチ、スケール、プラス・ドライバー、トラスロッド調整レンチをセット。

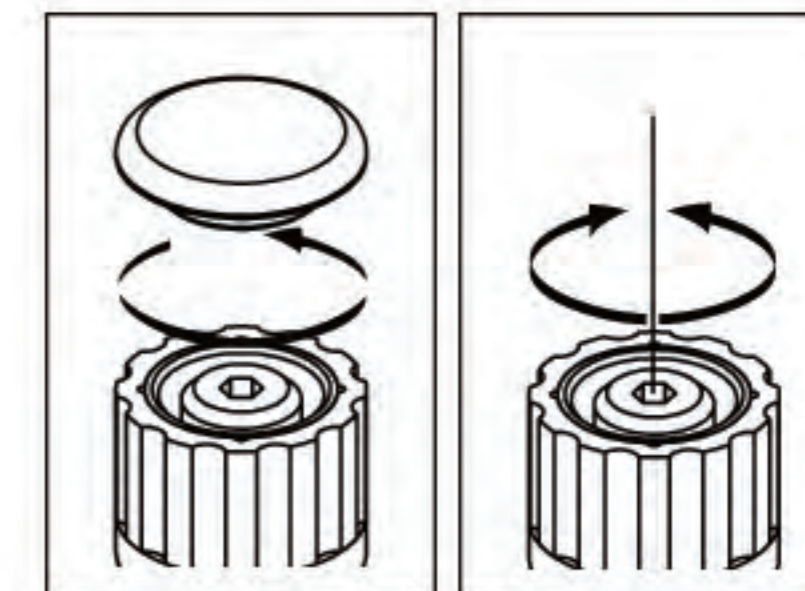

### Collet Knob

上位機種に相応しいメタル・ノブの質感と風合いはそのままに、ノブ操作時のスリッスを軽減するアウター・ラバーを装着した“Collet(コレット)ノブ”。内軸でPOTと固定される構造によりイモネジの緩みによるノブの落下を防止。

### Precision

全モデルを日本製とすることで、徹底した品質管理のもと、高精度を追求した組み込みと各部仕上げの緻密さを実現。

### Performance

高性能・高機能を念頭に開発されたIbanez が世界に誇るオリジナル・ハードウェア / パーツを随所に搭載。

### Playability

ハイ・ポジションでの演奏性を高めるオール・アクセス・ジョイント。素早いサウンド切替が可能なコントロール・レイアウト。そして、より弾きやすく改良を重ねたハイ・パフォーマンス(HP)ネック・シェイプ。いずれもプレイアビリティ向上のためのPrestige専用仕様。

### Prestige control

RG, FR, S, SV

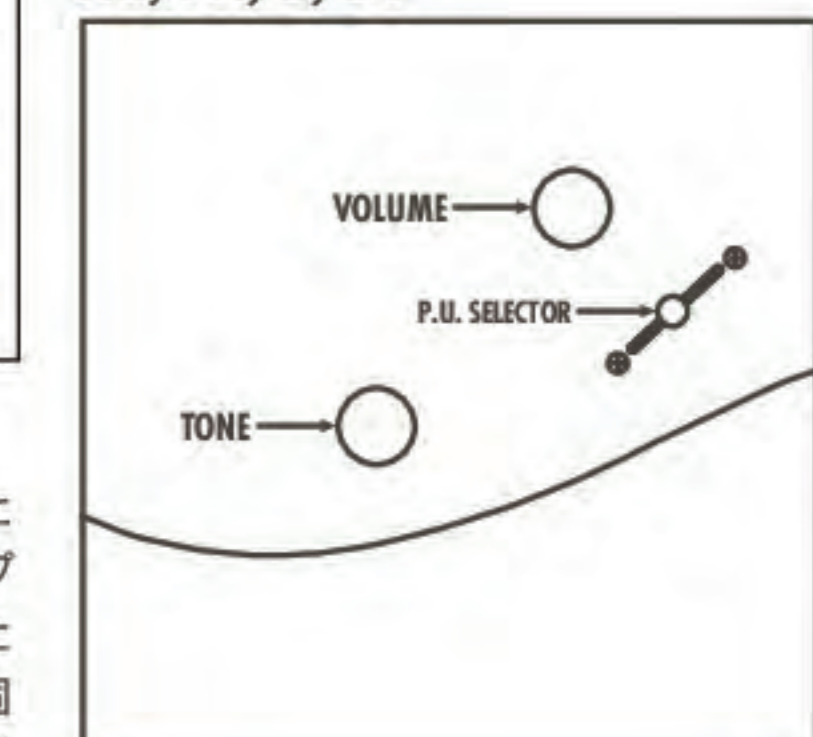

RGD

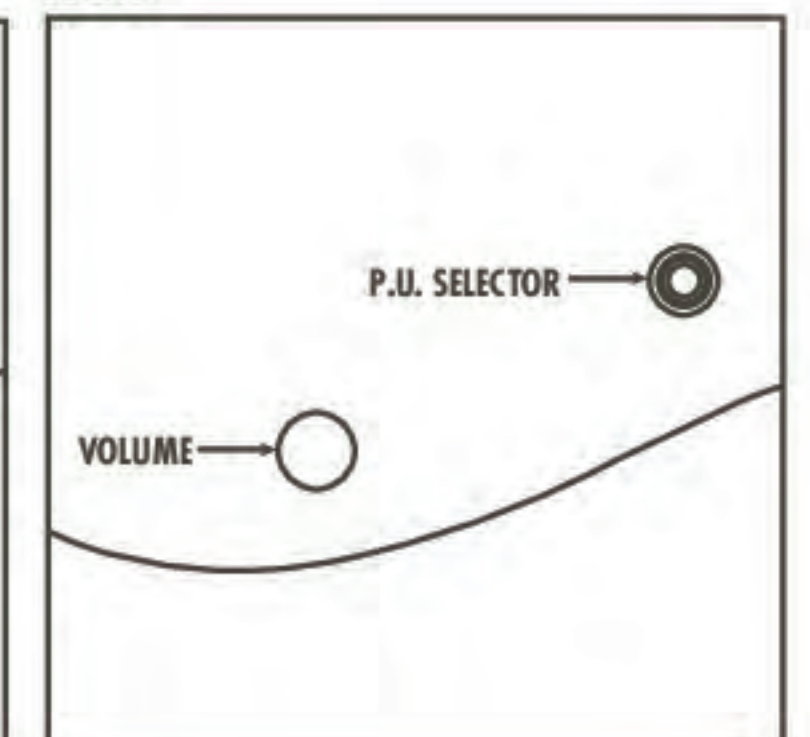



# RG *Prestige*

"Ibanezギターの代名詞"と評されること多いRG。開発当初から念頭に置かれた"スピーディな楽曲に適した演奏性の高さ"や"質実剛健かつ硬派なデザイン"はそのままに、現在の音楽シーンから求められる新たな要素を取り入れ、幅広い音楽ジャンルへ対応できる現在進行形のギターとして止むことのない進化を続けています。

## NEW MODEL



**BK**  
(Black)  
¥210,000 (本体価格 ¥200,000)

## RG3550ZDX MADE IN JAPAN

- 5pc Super Wizard HP Maple/Walnut neck w/ KTS™ TITANIUM rods
- Basswood body
- Rosewood fretboard
- 25.5inch Scale
- Edge-Zero tremolo bridge w/ ZPS3
- DiMarzio® Air Norton™ (H) neck PU
- DiMarzio® True Velvet™ Middle (S) middle PU
- DiMarzio® The Tone Zone® (H) bridge PU
- hardware color : Cosmo Black
- string : .009~.042 Round Wound (D'Addario:EXL120)
- color : BK (Black)
- includes : Hardshell case

## SPOT MODEL



**GK**  
(Galaxy Black)  
¥189,000 (本体価格 ¥180,000)

## RG3521 MADE IN JAPAN

- 5pc Super Wizard HP Maple/Walnut neck w/ KTS™ TITANIUM rods
- Basswood body
- Rosewood fretboard
- 25.5 inch Scale
- Tight-End R bridge
- DiMarzio® Air Norton™ (H) neck PU
- DiMarzio® The Tone Zone® (H) bridge PU
- hardware color : Cosmo Black
- string : .009~.042 Round Wound (D'Addario:EXL120)
- color : GK (Galaxy Black)
- includes : Hardshell case

## SPOT MODEL



**WH**  
(White)  
NEW FINISH  
¥204,750 (本体価格 ¥195,000)

## RG3250MZ MADE IN JAPAN

- 5pc Super Wizard HP Maple/Walnut neck w/ KTS™ TITANIUM rods
- Basswood body
- Maple fretboard
- 25.5 inch Scale
- Edge-Zero tremolo bridge w/ ZPS3
- DiMarzio® Air Norton™ (H) neck PU
- DiMarzio® True Velvet™ Middle (S) middle PU
- DiMarzio® The Tone Zone® (H) bridge PU
- hardware color : Cosmo Black
- string : .009~.042 Round Wound (D'Addario:EXL120)
- color : WH (White)
- includes : Hardshell case



**BK**  
(Black)  
¥194,250 (本体価格 ¥185,000)

## RG2620ZE MADE IN JAPAN

- 5pc Wizard HP Maple/Walnut neck
- Basswood body
- Rosewood fretboard
- 25.5 inch Scale
- Edge-Zero tremolo bridge w/ ZPS3
- EMG® 60 (H) neck PU
- EMG® 81 (H) bridge PU
- hardware color : Cosmo Black
- string : .009~.042 Round Wound (D'Addario:EXL120)
- color : BK (Black)
- includes : Hardshell case
- \*9V乾電池(OO6P)×1で駆動

## SPOT MODEL 7-STRING



**BK**  
(Black)  
¥204,750 (本体価格 ¥195,000)

## RG2627ZE MADE IN JAPAN

- 5pc Wizard-7 Maple/Wenge neck
- Basswood body
- Rosewood fretboard
- 25.5 inch Scale
- Edge-Zero 7 tremolo bridge w/ ZPS3
- EMG® 707 (H) neck PU
- EMG® 707 (H) bridge PU
- hardware color : Cosmo Black
- string : .009~.054 Round Wound (D'Addario:EXL120-7)
- color : BK (Black)
- includes : Hardshell case
- \*9V乾電池(OO6P)×1で駆動

## SPOT MODEL 8-STRING



**BK**  
(Black)  
¥252,000 (本体価格 ¥240,000)

## RG2228A MADE IN JAPAN

- 5pc Ultra-8 Maple/Wenge neck w/ KTS™ TITANIUM rods
- Basswood body
- Rosewood fretboard
- 27 inch Scale
- FX Edge III-8 bridge
- DiMarzio® D Activator 8™ Neck (H) neck PU
- DiMarzio® D Activator 8™ Bridge (H) bridge PU
- hardware color : Black
- string : .009~.065 Round Wound (D'Addario:EXL120-7 + XLB065)
- color : BK (Black)
- includes : Hardshell case
- factory tuning : 1D#, 2A#, 3F#, 4C#, 5G#, 6D#, 7A#, 8F

## NEW MODEL



**RS**  
(Red Spinel)

## RG2770FZ MADE IN JAPAN

- 5pc Wizard HP Maple/Walnut neck
- Flamed Maple + Maple (4mm) top / Mahogany (40mm) back body
- Rosewood fretboard
- 25.5inch Scale
- Edge-Zero tremolo bridge w/ ZPS3
- DiMarzio® IBZ-N (H) neck PU
- DiMarzio® IBZ-S (S) middle PU
- DiMarzio® IBZ-B (H) bridge PU
- hardware color : Cosmo Black
- string : .009~.042 Round Wound (D'Addario:EXL120)
- color : RS (Red Spinel)
- SPB (Sapphire Blue)
- TBK (Transparent Black)
- includes : Hardshell case



**SPB**  
(Sapphire Blue)



**TBK**  
(Transparent Black)  
¥199,500 (本体価格 ¥190,000)

## NEW MODEL 7-STRING



**TBK**  
(Transparent Black)  
¥210,000 (本体価格 ¥200,000)

## RG2727FZ MADE IN JAPAN

- 5pc Wizard-7 Maple/Wenge neck
- Flamed Maple + Maple (4mm) top / Mahogany (40mm) back body
- Rosewood fretboard
- 25.5inch Scale
- Edge-Zero 7 tremolo bridge w/ ZPS3
- DiMarzio® IBZ-7N (H) neck PU
- DiMarzio® IBZ-7B (H) bridge PU
- hardware color : Cosmo Black
- string : .009~.054 Round Wound (D'Addario:EXL120-7)
- color : TBK (Transparent Black)
- includes : Hardshell case



## NEW MODEL



**RVK**  
(Red Viking)



**SPB**  
(Sapphire Blue)



**TBK**  
(Transparent Black)  
¥189,000 (本体価格 ¥180,000)

## RG2770FV

MADE IN JAPAN

- 5pc Wizard HP Maple/Walnut neck
- Flamed Maple + Maple (4mm) top / Alder (40mm) back body
- Rosewood fretboard
- 25.5inch Scale
- SynchroniZR tremolo bridge w/ ZPS-FX
- Ibanez TDB2 (H) neck PU
- Ibanez ST2 (S) middle PU
- Ibanez TDB3 (H) bridge PU
- hardware color: Cosmo Black
- string: .009~.042 Round Wound (D'Addario:EXL120)
- color: RVK (Red Viking)  
SPB (Sapphire Blue)  
TBK (Transparent Black)
- includes: Hardshell case

## NEW MODEL



**RS**  
(Red Spinel)



**TAB**  
(Transparent Aqua Blue)



**TBK**  
(Transparent Black)  
¥204,750 (本体価格 ¥195,000)

## RG2750QV

MADE IN JAPAN

- 5pc Wizard HP Maple/Walnut neck
- Quilted Maple + Maple (4mm) top / Alder (40mm) back body
- Rosewood fretboard
- 25.5inch Scale
- SynchroniZR tremolo bridge w/ ZPS-FX
- Ibanez TDB2 (H) neck PU
- Ibanez ST2 (S) middle PU
- Ibanez TDB3 (H) bridge PU
- hardware color: Chrome
- string: .009~.042 Round Wound (D'Addario:EXL120)
- color: RS (Red Spinel)  
TAB (Transparent Aqua Blue)  
TBK (Transparent Black)
- includes: Hardshell case

## NEW MODEL



**CS**  
(Cherry Sunburst)



**TBK**  
(Transparent Black)  
¥199,500 (本体価格 ¥190,000)

## RG2720QZ

MADE IN JAPAN

- 5pc Wizard HP Maple/Walnut neck
- Quilted Maple + Maple (4mm) top / Mahogany (40mm) back body
- Rosewood fretboard
- 25.5inch Scale
- Edge-Zero tremolo bridge w/ ZPS3
- DiMarzio® IBZ-N (H) neck PU
- DiMarzio® IBZ-B (H) bridge PU
- hardware color: Cosmo Black
- string: .009~.042 Round Wound (D'Addario:EXL120)
- color: CS (Cherry Sunburst)  
TBK (Transparent Black)
- includes: Hardshell case

## NEW MODEL



**TBK**  
(Transparent Black)



**TOR**  
(Transparent Orange)  
¥194,250 (本体価格 ¥185,000)

## RG2721Q

MADE IN JAPAN

- 5pc Wizard HP Maple/Walnut neck
- Quilted Maple + Maple (4mm) top / Mahogany (40mm) back body
- Rosewood fretboard
- 25.5inch Scale
- Tight-End R bridge
- DiMarzio® IBZ-N (H) neck PU
- DiMarzio® IBZ-B (H) bridge PU
- hardware color: Cosmo Black
- string: .009~.042 Round Wound (D'Addario:EXL120)
- color: TBK (Transparent Black)  
TOR (Transparent Orange)
- includes: Hardshell case

## RG2570Z

MADE IN JAPAN



**BK**  
(Black)  
¥162,750 (本体価格 ¥155,000)

- 5pc Wizard HP Maple/Walnut neck
- Basswood body
- Rosewood fretboard
- 25.5 inch Scale
- Edge-Zero tremolo bridge w/ ZPS3
- DiMarzio® IBZ-N (H) neck PU
- DiMarzio® IBZ-S (S) middle PU
- DiMarzio® IBZ-B (H) bridge PU
- hardware color: Cosmo Black
- string: .009~.042 Round Wound (D'Addario:EXL120)
- color: BK (Black)
- includes: Hardshell case

## RG2570MZ

MADE IN JAPAN



**WH**  
(White)  
¥168,000 (本体価格 ¥160,000)

- 5pc Wizard HP Maple/Walnut neck
- Basswood body
- Maple fretboard
- 25.5 inch Scale
- Edge-Zero tremolo bridge w/ ZPS3
- DiMarzio® IBZ-N (H) neck PU
- DiMarzio® IBZ-S (S) middle PU
- DiMarzio® IBZ-B (H) bridge PU
- hardware color: Cosmo Black
- string: .009~.042 Round Wound (D'Addario:EXL120)
- color: WH (White)
- includes: Hardshell case





**GK**  
(Galaxy Black)

**RG2550Z** **MADE IN JAPAN**

- 5pc Wizard HP Maple/Walnut neck
- Basswood body
- Rosewood fretboard
- 25.5 inch Scale
- Edge-Zero tremolo bridge w/ ZPS3
- DiMarzio® IBZ-N (H) neck PU
- DiMarzio® IBZ-S (S) middle PU
- DiMarzio® IBZ-B (H) bridge PU
- hardware color : Cosmo Black
- string : .009~.042 Round Wound (D'Addario:EXL120)
- color : GK (Galaxy Black)  
GW (Galaxy White)
- includes : Hardshell case



**GW**  
(Galaxy White)

¥162,750 (本体価格 ¥155,000)

**NEW MODEL**



**CW**  
(Crimson Wine)

**RG2540ZEX** **MADE IN JAPAN**

- 5pc Wizard HP Maple/Walnut neck
- Ash body
- Rosewood fretboard
- 25.5 inch Scale
- Edge-Zero tremolo bridge w/ ZPS3
- DiMarzio® IBZ-S-R (S) neck PU
- DiMarzio® IBZ-S (S) middle PU
- DiMarzio® IBZ-B (H) bridge PU
- hardware color : Cosmo Black
- string : .009~.042 Round Wound (D'Addario:EXL120)
- color : CW (Crimson Wine)  
LDK (Lightning Through A Dark)
- includes : Hardshell case



**LDK**  
(Lightning Through A Dark)

¥178,500 (本体価格 ¥170,000)

**NEW MODEL**



**BK**  
(Black)

**RG1550MV** **MADE IN JAPAN**

- 5pc Wizard HP Maple/Walnut neck
- Alder body
- Maple fretboard
- 25.5 inch Scale
- SynchroniZR tremolo bridge w/ ZPS-FX
- Ibanez V7 (H) neck PU
- Ibanez S1 (S) middle PU
- Ibanez V8 (H) bridge PU
- hardware color : Cosmo Black
- string : .009~.042 Round Wound (D'Addario:EXL120)
- color : BK (Black)
- includes : Hardshell case

¥132,300 (本体価格 ¥126,000)

**7-STRING**



**BK**  
(Black)

**RG1527Z** **MADE IN JAPAN**

- 5pc Wizard-7 Maple/Wenge neck
- Basswood body
- Rosewood fretboard
- 25.5 inch Scale
- Edge-Zero 7 tremolo bridge w/ ZPS3
- Ibanez V77 (H) neck PU
- Ibanez V87 (H) bridge PU
- hardware color : Cosmo Black
- string : .009~.054 Round Wound (D'Addario:EXL120-7)
- color : BK (Black)
- includes : Hardshell case

¥152,250 (本体価格 ¥145,000)

**SPOT MODEL Left-handed**



**BK**  
(Black)

**RG1570ZL** **MADE IN JAPAN**

- 5pc Wizard HP Maple/Walnut neck
- Basswood body
- Rosewood fretboard
- 25.5 inch Scale
- Edge-Zero tremolo bridge w/ ZPS3
- Ibanez V7 (H) neck PU
- Ibanez S1 (S) middle PU
- Ibanez V8 (H) bridge PU
- hardware color : Cosmo Black
- string : .009~.042 Round Wound (D'Addario:EXL120)
- color : BK (Black)
- includes : Hardshell case

¥136,500 (本体価格 ¥130,000)

**RGD Prestige**

26.5インチ・スケールとダウン・チューニングによって、プレイアビリティを損なうことなく低音域へのアプローチを容易にしたRGD。

**NEW MODEL SPOT MODEL 7-STRING**



**ISH**  
(Invisible Shadow)

**RGD2127FX** **MADE IN JAPAN**

- 5pc Wizard-7 Maple/Wenge neck w/ KTS™ TITANIUM rods
- Basswood body
- Rosewood fretboard
- 26.5 inch Scale
- Tight-End R-7 bridge
- Ibanez V77 Custom (H) neck PU
- Ibanez V87 Custom (H) bridge PU
- hardware color : Cosmo Black
- string : .010~.059 Round Wound (D'Addario:EXL110-7)
- color : ISH (Invisible Shadow)
- includes : Hardshell case
- factory tuning : 1D, 2A, 3F, 4C, 5G, 6D, 7A

¥173,250 (本体価格 ¥165,000)

**7-STRING**



**ISH**  
(Invisible Shadow)

**RGD2127Z** **MADE IN JAPAN**

- 5pc Wizard-7 Maple/Walnut neck w/ KTS™ TITANIUM rods
- Basswood body
- Rosewood fretboard
- 26.5 inch Scale
- Edge-Zero 7 tremolo bridge w/ ZPS3
- Ibanez V77 Custom (H) neck PU
- Ibanez V87 Custom (H) bridge PU
- hardware color : Cosmo Black
- string : .010~.059 Round Wound (D'Addario:EXL110-7)
- color : ISH (Invisible Shadow)
- includes : Hardshell case
- factory tuning : 1D, 2A, 3F, 4C, 5G, 6D, 7A

¥178,500 (本体価格 ¥170,000)

**FR Prestige**

スローガンである“Free style Rock gear”が表すとおり、“あらゆる音楽ジャンルに対応可能なデザインとサウンド”を備えたFR。



**BK**  
(Black)

**FR1620** **MADE IN JAPAN**

- 5pc Wizard HP Maple/Walnut neck
- Ash body
- Rosewood fretboard
- 25.5 inch Scale
- Tight-End bridge
- CAP-CCR1 (H) neck PU
- CAP-CCR2 (H) bridge PU
- hardware color : Chrome
- string : .009~.042 Round Wound (D'Addario:EXL120)
- color : BK (Black)
- includes : Hardshell case

¥162,750 (本体価格 ¥155,000)



# S Prestige

トップ、バックともに美しい曲線を描き極限まで薄く成型されたスタイル。マホガニー・ボディが生み出すファットでレゾナンス豊かなトーン。他に類を見ないほどに薄いネック・シェイプが実現する抜群のプレイアビリティ。そのいずれもがSのアイデンティティである。

## NEW MODEL SPOT MODEL 7-STRING



**TKS**  
(Transparent Black Sunburst)  
¥225,750 (本体価格 ¥215,000)

### \$5427 MADE IN JAPAN

- 5pc Wizard-7 Maple/Wenge neck
- Mahogany body
- Rosewood fretboard
- 25.5 inch Scale
- ZR-7 tremolo bridge w/ ZPS2
- Ibanez V77 (H) neck PU
- Ibanez V87 (H) bridge PU
- hardware color: Cosmo Black
- string: .009~.054 Round Wound (D'Addario:EXL120-7)
- color: TKS (Transparent Black Sunburst)
- includes: Hardshell case



**TKS**  
(Transparent Black Sunburst)  
¥199,500 (本体価格 ¥190,000)

### \$5470 MADE IN JAPAN

- 5pc Super Wizard HP Maple/Walnut neck w/ KTS™ TITANIUM rods
- Mahogany body
- Rosewood fretboard
- 25.5 inch Scale
- ZR-2 tremolo bridge w/ ZPS3
- Ibanez HGD1 (H) neck PU
- Ibanez ST2 (S) middle PU
- Ibanez HGD2 (H) bridge PU
- hardware color: Cosmo Black
- string: .009~.042 Round Wound (D'Addario:EXL120)
- color: TKS (Transparent Black Sunburst)
- includes: Hardshell case



**RVK**  
(Red Viking)  
¥215,250 (本体価格 ¥205,000)

### \$5470F MADE IN JAPAN

- 5pc Super Wizard HP Maple/Walnut neck w/ KTS™ TITANIUM rods
- Flamed Maple top / Mahogany body
- Rosewood fretboard
- 25.5 inch Scale
- ZR-2 tremolo bridge w/ ZPS3
- Ibanez HGD1 (H) neck PU
- Ibanez ST2 (S) middle PU
- Ibanez HGD2 (H) bridge PU
- hardware color: Cosmo Black
- string: .009~.042 Round Wound (D'Addario:EXL120)
- color: RVK (Red Viking)
- includes: Hardshell case



**WCB**  
(Wild Cherry Blossom)  
¥225,750 (本体価格 ¥215,000)

### \$5470Q MADE IN JAPAN

- 5pc Super Wizard HP Maple/Walnut neck w/ KTS™ TITANIUM rods
- Quilted Maple top / Mahogany body
- Rosewood fretboard
- 25.5 inch Scale
- ZR-2 tremolo bridge w/ ZPS3
- Ibanez HGD1 (H) neck PU
- Ibanez ST2 (S) middle PU
- Ibanez HGD2 (H) bridge PU
- hardware color: Cosmo Black
- string: .009~.042 Round Wound (D'Addario:EXL120)
- color: SPB (Sapphire Blue)
- includes: Hardshell case

# SV Prestige

"Serious Versatility" の名に相応しい多才さを追求したSV。支点部に高精度のボール・ベアリングを採用したノン・ロッキング式ゼロ・レジスタンス(ZR)・シンクロナイザー(SynchroniZR)・トレモロ・ブリッジが実現するスムーズなアクションと、プッシュ/プル式のノブを搭載しH-S-Hピックアップ配列を最大限活かしたサウンド・バリエーションが、その多才さの裏付けだ。



**BK**  
(Black)  
¥194,250 (本体価格 ¥185,000)

### SV5470 MADE IN JAPAN

- 5pc Wizard HP Maple/Walnut neck
- Maple top / Mahogany body
- Rosewood fretboard
- 25.5 inch Scale
- SynchroniZR tremolo bridge w/ ZPS-FX
- Ibanez TDB2 (H) neck PU
- Ibanez ST2 (S) middle PU
- Ibanez TDB3 (H) bridge PU
- hardware color: Cosmo Black
- string: .009~.042 Round Wound (D'Addario:EXL120)
- color: BK (Black)
- includes: Hardshell case



**CW**  
(Crimson Wine)  
¥210,000 (本体価格 ¥200,000)

### SV5470A MADE IN JAPAN

- 5pc Wizard HP Maple/Walnut neck
- Ash top / Mahogany body
- Rosewood fretboard
- 25.5 inch Scale
- SynchroniZR tremolo bridge w/ ZPS-FX
- Ibanez TDB2 (H) neck PU
- Ibanez ST2 (S) middle PU
- Ibanez TDB3 (H) bridge PU
- hardware color: Cosmo Black
- string: .009~.042 Round Wound (D'Addario:EXL120)
- color: CW (Crimson Wine)
- includes: Hardshell case

## NEW MODEL



**SPB**  
(Sapphire Blue)  
¥210,000 (本体価格 ¥200,000)

### SV5470F MADE IN JAPAN

- 5pc Wizard HP Maple/Walnut neck
- Flamed Maple top / Mahogany body
- Rosewood fretboard
- 25.5 inch Scale
- SynchroniZR tremolo bridge w/ ZPS-FX
- Ibanez TDB2 (H) neck PU
- Ibanez ST2 (S) middle PU
- Ibanez TDB3 (H) bridge PU
- hardware color: Cosmo Black
- string: .009~.042 Round Wound (D'Addario:EXL120)
- color: SPB (Sapphire Blue)
- includes: Hardshell case

## Prestige Switching Systems

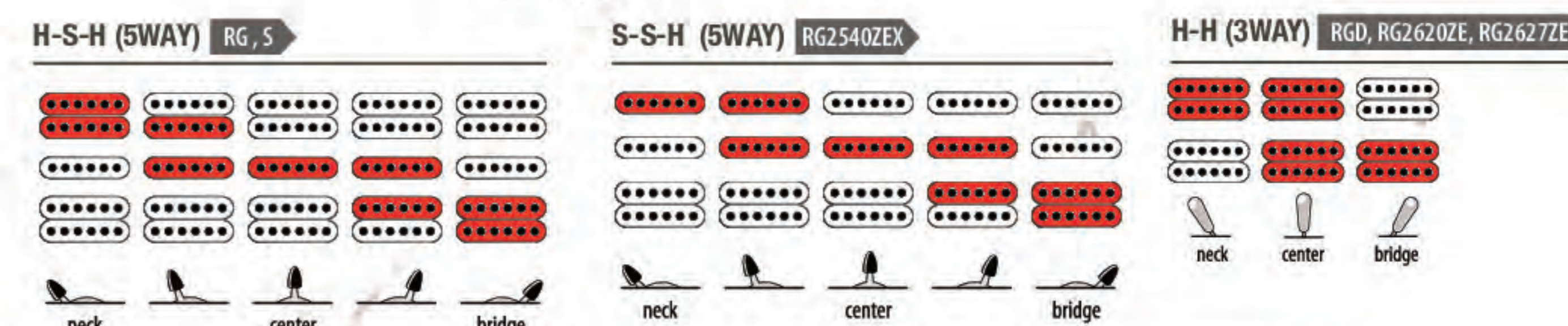

### H-S-H (5WAY) SV, RG2770FV, RG2750QV Stacked Single Coil

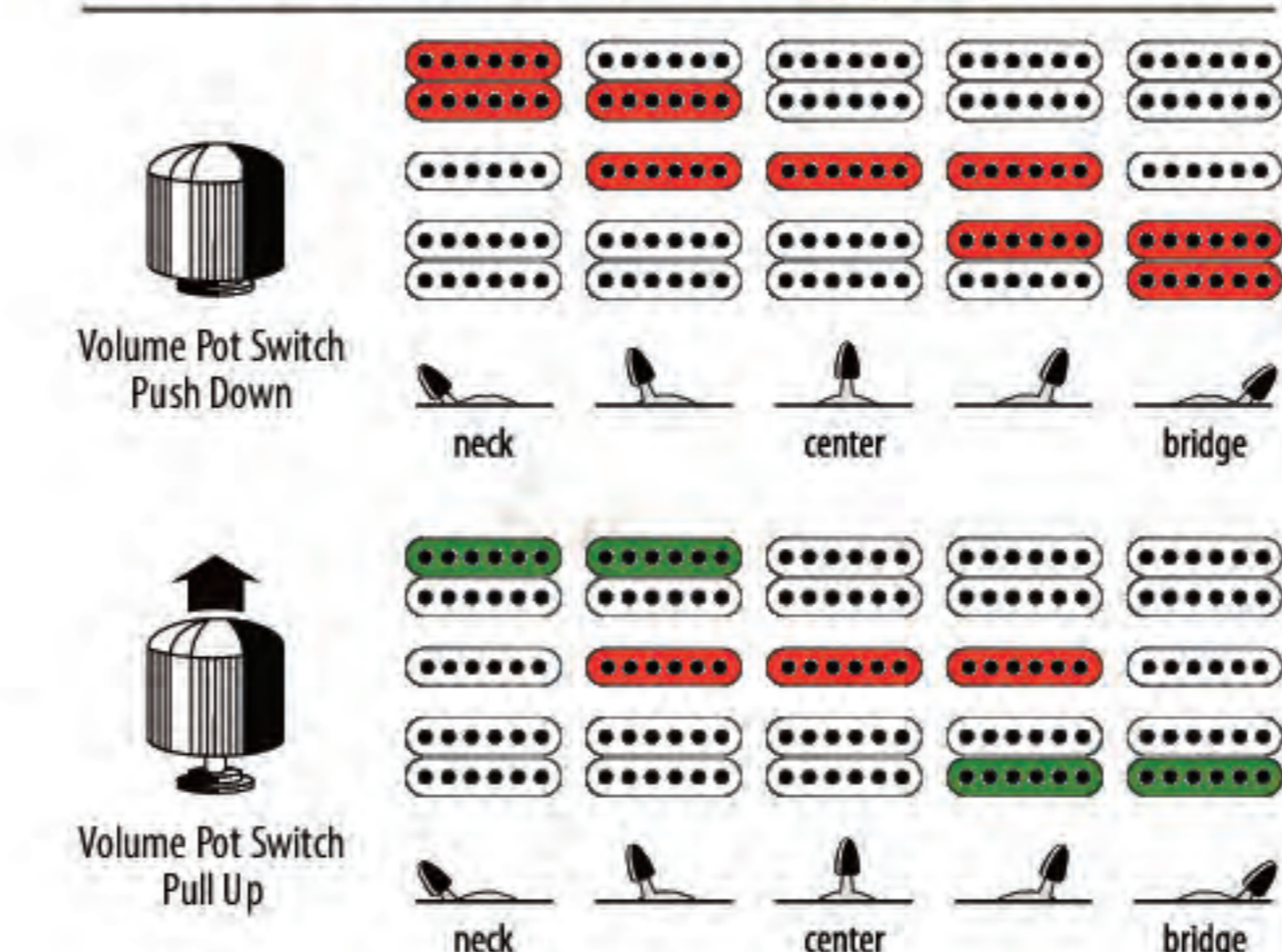

### H-S-H (5WAY) RG1550MV

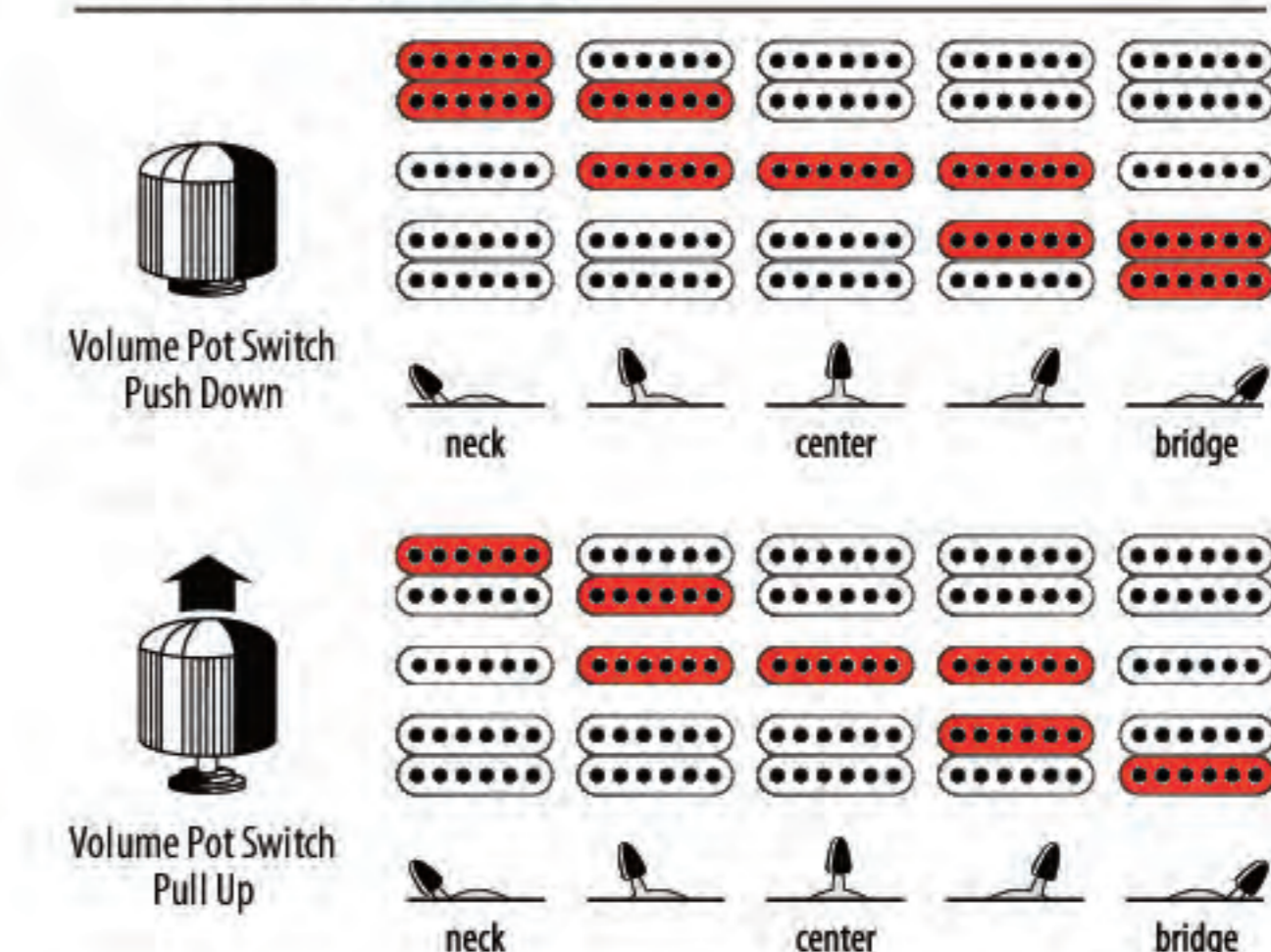

### H-H (5WAY) RG, S

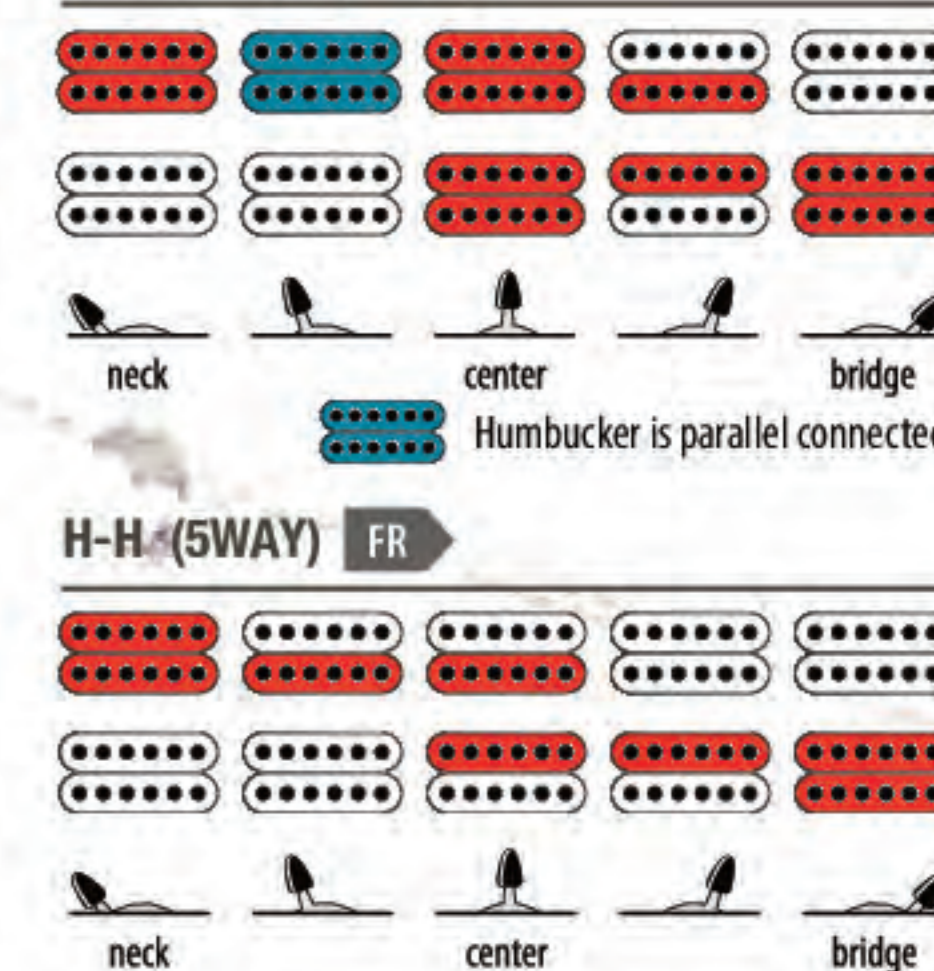





## PREMIUM

### PERFORMANCE BEYOND EXPECTATION

プレイアビリティ、ハードウェアの性能とオリジナリティ。それらはIbanezのギターとベースが追求するハイ・パフォーマンスには欠かせない要素である。カスタム・モデルや高級品ならいざ知らず、それらを選ばなくとも信頼性とパフォーマンスの高い製品をもっと多くのギタリストやベーシストに届けることができないだろうか？ これらを命題に、既存のイメージを覆すほどの可能性を秘めた“期待以上のハイ・パフォーマンス・ギア”、Ibanez “Premium”。



**PREMIUM Fret Treatment Tool**

より一層の弾き心地を実現するため、j.custom 同様フレット・エッジの球面加工を施しています。(フレット：ジャンボ・フレット)



PREMIUM モデルのメンテナンスに最適なマルチ・ツール・キット付属。各サイズのレンチ、スケール、プラス・ドライバー、トラスロッド調整レンチをセット。



**Zero Point System**  
(ZPS3, ZPS3Fe, ZPS2)

通常のスプリングに加え、アディショナル・スプリング 2 本とストップ・ロッドをもつゼロ・ポイント・システム。トレモロ・ユニットを常にセンター位置 (Zero Point) に保とうとする働きを持ち、弦の張力の変化を低減し安定した環境を実現。



**Edge-Zero II**  
**Tremolo Bridge**

ナイフエッジ支点構造、差し込み式のアームといった特徴を持つ Ibanez 伝統のトレモロ・ブリッジ “Edge” のコンセプトを受け継いだ “Edge-Zero II” トレモロ・ブリッジ。



**ZR-2**  
**Tremolo Bridge**

ダブル・ロッキング・トレモロの常識をくつがえす、ZR-2 (ゼロ・レジスタンス-2) トレモロ・ブリッジ。支定点に高精度のボール・ベアリングを採用し、従来のナイフ・エッジ方式とは異なるスムーズなアクションと操作性、そして高いチューニング精度を実現。



# RG PREMIUM

## SPOT MODEL



**CNF**  
(Charcoal Brown Flat)  
¥92,400 (本体価格 ¥88,000)

## RG721

- 5pc Wizard Maple/Walnut neck
- Sonokeling top / American Basswood body
- Rosewood fretboard
- 25.5inch Scale
- Tight-End R bridge
- CAP-VM1 (H) neck PU
- CAP-VM2 (H) bridge PU
- hardware color : Cosmo Black
- string : .010~.046 Round Wound (D'Addario:EXL110)
- color : CNF (Charcoal Brown Flat)
- includes : Gigcase

## NEW MODEL SPOT MODEL



**RDT**  
(Red Desert)  
¥131,250 (本体価格 ¥125,000)

## RG920QMZ

- 5pc Wizard Maple/Walnut neck
- Quilted Maple top / American Basswood body
- Rosewood fretboard
- 25.5inch Scale
- Edge-Zero II tremolo bridge w/ ZPS3Fe
- DiMarzio® IBZ-N (H) neck PU
- DiMarzio® IBZ-B (H) bridge PU
- hardware color : Cosmo Black
- string : .009~.042 Round Wound (D'Addario:EXL120)
- color : RDT (Red Desert)
- includes : Gigcase

## NEW MODEL SPOT MODEL



**BI**  
(Black Ice)

## RG950QMZ

- 5pc Wizard Maple/Walnut neck
- Quilted Maple top / American Basswood body
- Rosewood fretboard
- 25.5inch Scale
- Edge-Zero II tremolo bridge w/ ZPS3Fe
- DiMarzio® IBZ-N (H) neck PU
- DiMarzio® IBZ-S (S) middle PU
- DiMarzio® IBZ-B (H) bridge PU
- hardware color : Cosmo Black
- string : .009~.042 Round Wound (D'Addario:EXL120)
- color : BI (Black Ice)  
CBE (Cobalt Blue Surge)  
RDT (Red Desert)
- includes : Gigcase



**CBE**  
(Cobalt Blue Surge)



**RDT**  
(Red Desert)  
¥126,000 (本体価格 ¥120,000)

## NEW MODEL SPOT MODEL



**BDK**  
(Blazing Dusk)  
¥126,000 (本体価格 ¥120,000)

## RG970QMZ

- 5pc Wizard Maple/Walnut neck
- Quilted Maple top / American Basswood body
- Rosewood fretboard
- 25.5inch Scale
- Edge-Zero II tremolo bridge w/ ZPS3Fe
- DiMarzio® IBZ-N (H) neck PU
- DiMarzio® IBZ-S (S) middle PU
- DiMarzio® IBZ-B (H) bridge PU
- hardware color : Cosmo Black
- string : .009~.042 Round Wound (D'Addario:EXL120)
- color : BDK (Blazing Dusk)
- includes : Gigcase

# S PREMIUM

## SPOT MODEL



**BK**  
(Black)  
¥131,250 (本体価格 ¥125,000)

## S920E

- 5pc Wizard Maple/Walnut neck
- African Mahogany body
- Rosewood fretboard
- 25.5inch Scale
- ZR-2 tremolo bridge w/ ZPS3
- EMG® 60 (H) neck PU
- EMG® 81 (H) bridge PU
- hardware color : Cosmo Black
- string : .009~.042 Round Wound (D'Addario:EXL120)
- color : BK (Black)
- includes : Gigcase
- \*9V乾電池(006P)×1で駆動

## SPOT MODEL



**NT**  
(Natural)  
¥131,250 (本体価格 ¥125,000)

## S970CW

- 5pc Wizard Maple/Walnut neck
- Claro Walnut top / African Mahogany body
- Rosewood fretboard w/ Maple binding
- 25.5 inch Scale
- ZR-2 tremolo bridge w/ ZPS3
- CAP-CL1 (H) neck PU
- CAP-VM15 (S) middle PU
- CAP-CL2 (H) bridge PU
- hardware color : Cosmo Black
- string : .009~.042 Round Wound (D'Addario:EXL120)
- color : NT (Natural)
- includes : Gigcase

### RG721 / RG920QMZ

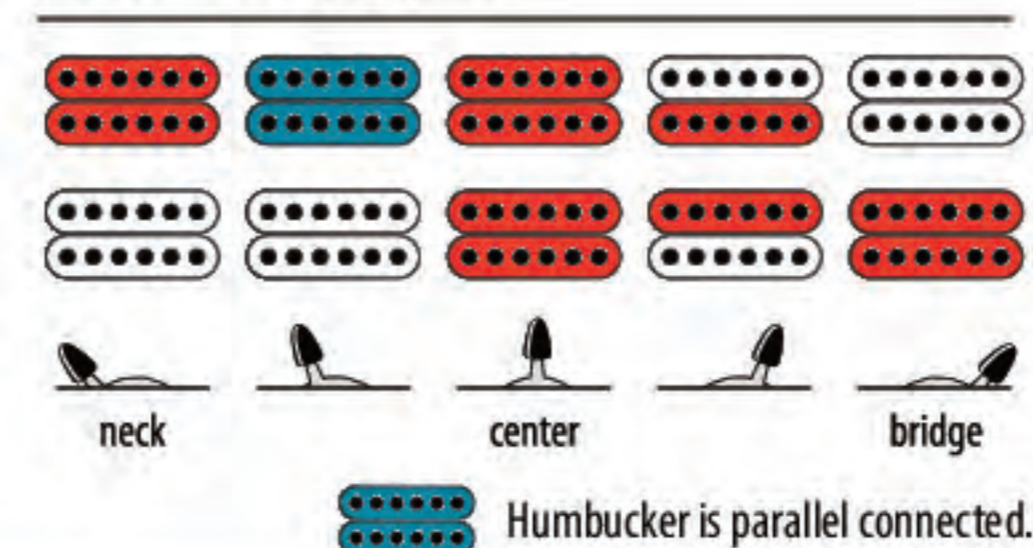

### RG950QMZ / RG970QMZ / S970CW

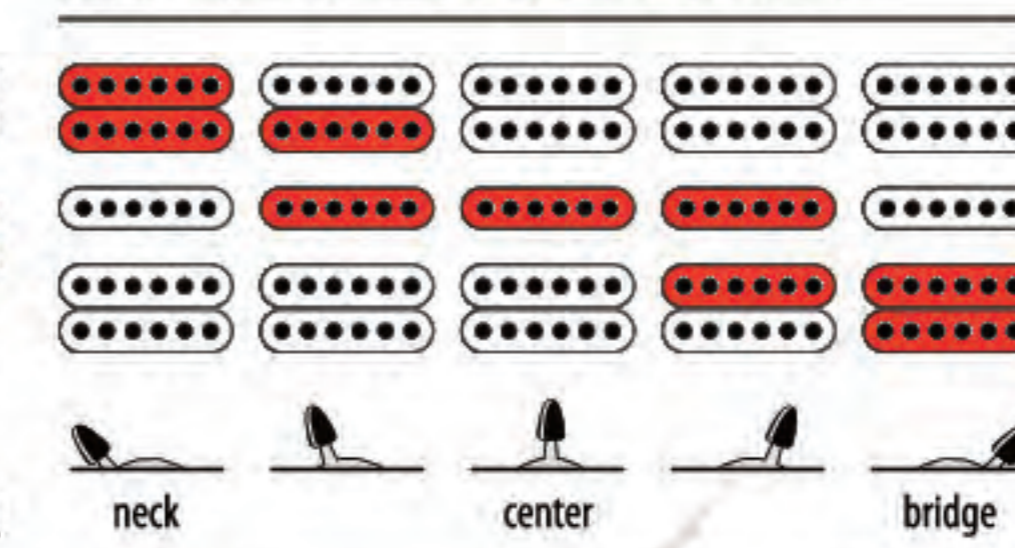

### S920E

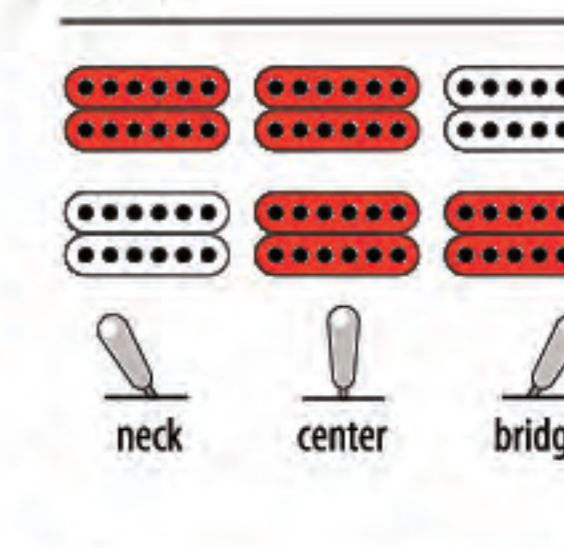

### PREMIUM Control S920E

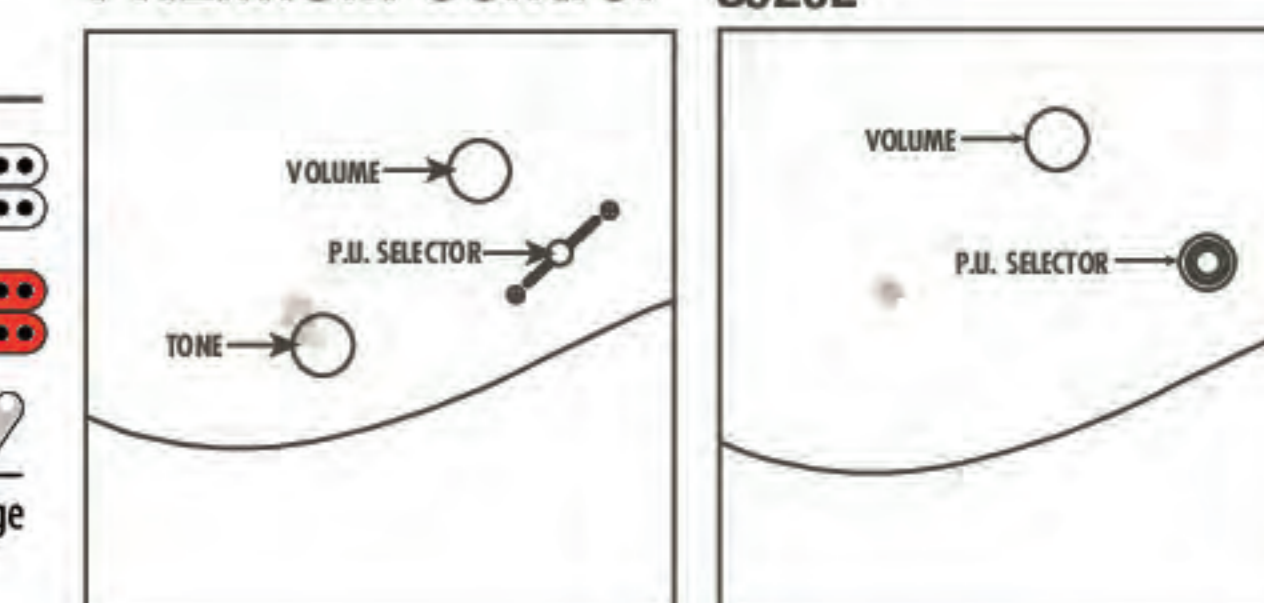





# IRON LABEL

## METAL TO THE CORE

常にヘヴィ・ロックと共にあり、常にそれらのプレイヤーに対して真摯であった我々Ibanezが、改良と微調整を重ねようやく完成させることが出来たギター、それがIRON LABEL。究極のプレイアビリティを求め、IRON LABELではIbanezギターの最大の特徴であるWizardネックに更なる改良を加え、握り易さとスピーディなプレイに対応する薄さの向上を実現しつつも、実用レベルでの検証を重ねた耐久性・剛性を犠牲にしないNitro Wizard (ナイトロ・ウィザード) ネックを新たに採用。また、IRON LABELシリーズは、全機種にUSA製のEMG®またはDiMarzio®ピックアップを装備。

### IRONLABEL control

RG

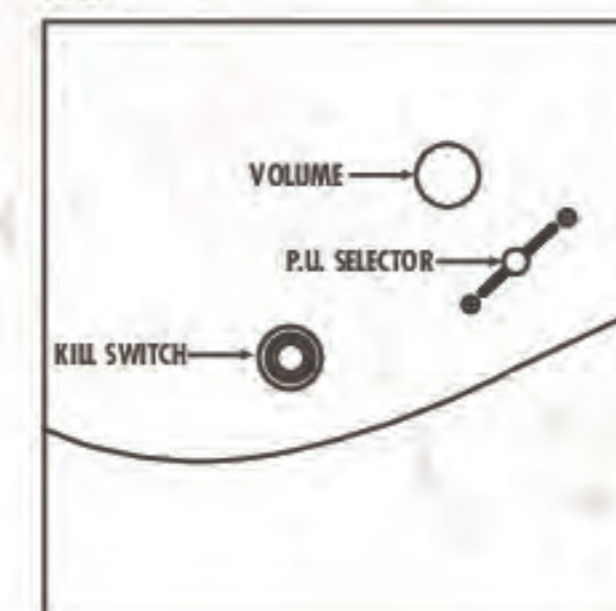

S

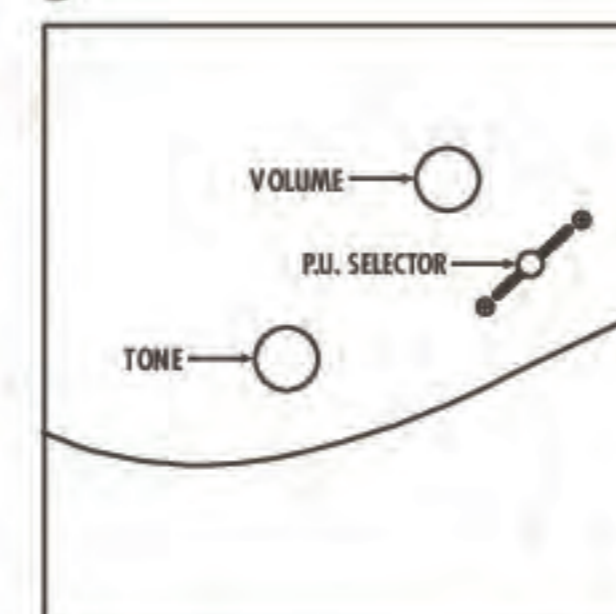

RGIR

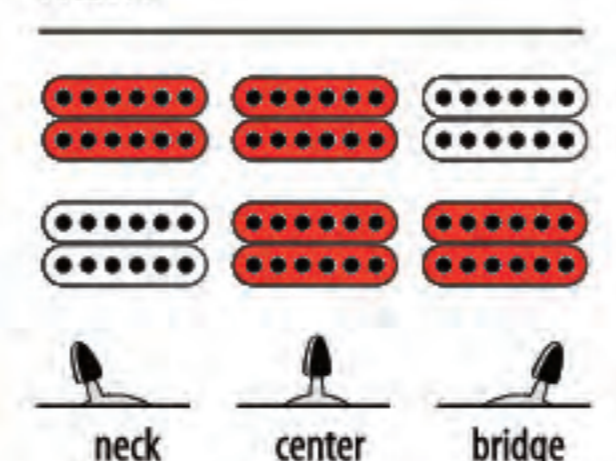

SIR27FD

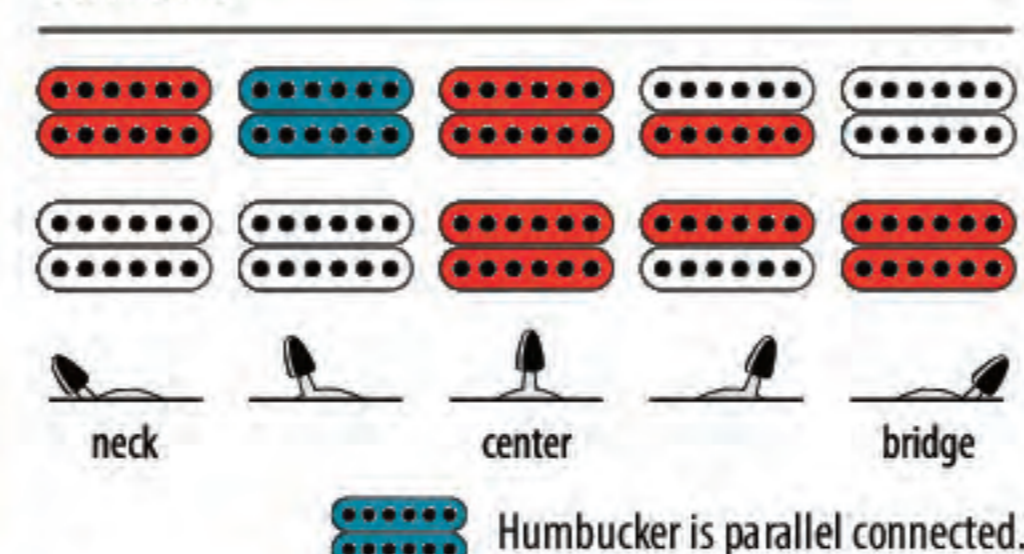

SIR70FD

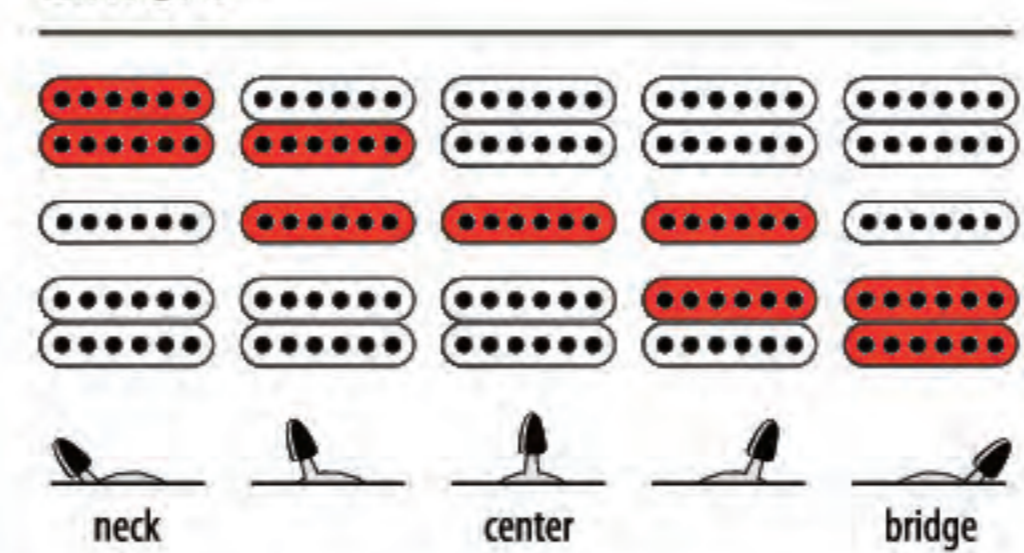

### Gibraltar Standard Bridge

サドルの横ぶれを防止する堅牢な構造を持ち、豊かなサスティーンを誇るGibraltar Standard フィクスド・ブリッジ。好みに応じてボディバックまたはブリッジエンドいずれかのポールフルッキングが可能。



### Edge-Zero II Tremolo Bridge

ナイフエッジ支点構造、差し込み式のアームといった特徴を持つIbanez伝統のトレモロ・ブリッジ“Edge”のコンセプトを受け継いだ“Edge-Zero II”トレモロ・ブリッジ。

### NEW MODEL SPOT MODEL 8-STRING



¥115,500 (本体価格 ¥110,000)

### RGIR28FE

- 5pc Nitro Wizard-8 Maple/Walnut neck w/ KTS™ TITANIUM rods
- Basswood body
- Rosewood fretboard
- 25.5inch Scale
- Gibraltar Standard-8 bridge
- EMG® 808 (H) neck PU
- EMG® 808 (H) bridge PU
- hardware color: Cosmo Black
- string: .009-.065 Round Wound (D'Addario:EXL120-7 + XLB065)
- color: BK (Black)
- factory tuning: 1D#, 2A#, 3F#, 4C#, 5G#, 6D#, 7A#, 8F
- \*9V乾電池(O06P)×1で駆動

### NEW MODEL 7-STRING



¥94,500 (本体価格 ¥90,000)

### RGIR27FE

- 3pc Nitro Wizard-7 Maple/Bubinga neck
- Basswood body
- Rosewood fretboard
- 25.5inch Scale
- Gibraltar Standard-7 bridge
- EMG® 707 (H) neck PU
- EMG® 707 (H) bridge PU
- hardware color: Cosmo Black
- string: .010-.059 Round Wound (D'Addario:EXL110-7)
- color: BK (Black)
- \*9V乾電池(O06P)×1で駆動

### NEW MODEL



¥84,000 (本体価格 ¥80,000)

### RGIR20FE

- 3pc Nitro Wizard Maple/Bubinga neck
- Basswood body
- Rosewood fretboard
- 25.5inch Scale
- Gibraltar Standard bridge
- EMG® 60 (H) neck PU
- EMG® 81 (H) bridge PU
- hardware color: Cosmo Black
- string: .010-.046 Round Wound (D'Addario:EXL110)
- color: BK (Black)
- WH (White)
- \*9V乾電池(O06P)×1で駆動

### NEW MODEL 7-STRING



¥105,000 (本体価格 ¥100,000)

### SIR27FD

- 3pc Nitro Wizard-7 Maple/Bubinga neck
- Mahogany body
- Rosewood fretboard
- 25.5inch Scale
- Gibraltar Standard-7 bridge
- DiMarzio® PAF® 7 (H) neck PU
- DiMarzio® PAF® 7 (H) bridge PU
- hardware color: Cosmo Black
- string: .010-.059 Round Wound (D'Addario:EXL110-7)
- color: IPT (Iron Pewter)

### NEW MODEL



¥94,500 (本体価格 ¥90,000)

### SIR70FD

- 3pc Nitro Wizard Maple/Bubinga neck
- Mahogany body
- Rosewood fretboard
- 25.5inch Scale
- Gibraltar Standard-7 bridge
- DiMarzio® Air Norton™ (H) neck PU
- DiMarzio® True Velvet™ Middle (S) middle PU
- DiMarzio® The Tone Zone® (H) bridge PU
- hardware color: Cosmo Black
- string: .010-.046 Round Wound (D'Addario:EXL110)
- color: IPT (Iron Pewter)



# RG

## NEW MODEL



**BK**  
(Black)

### RG470DXB

- 3pc Wizard III Maple neck
- Basswood body
- Rosewood fretboard
- 25.5inch Scale
- Edge-Zero II tremolo bridge
- Ibanez INF3 (H) neck PU
- Ibanez INF53 (S) middle PU
- Ibanez INF4 (H) bridge PU
- hardware color : Black
- string : .009~.042 Round Wound (D'Addario:EXL120)
- color : BK (Black)  
WH (White)



**WH**  
(White)

¥52,500 (本体価格 ¥50,000)

## NEW MODEL



**WH**  
(White)

### RG450DXB

- 3pc Wizard III Maple neck
- Basswood body
- Rosewood fretboard
- 25.5inch Scale
- Edge-Zero II tremolo bridge
- Ibanez INF3 (H) neck PU
- Ibanez INF53 (S) middle PU
- Ibanez INF4 (H) bridge PU
- hardware color : Black
- string : .009~.042 Round Wound (D'Addario:EXL120)
- color : WH (White)

¥52,500 (本体価格 ¥50,000)

## NEW MODEL



**BK**  
(Black)

### RG450DX

- 3pc Wizard III Maple neck
- Basswood body
- Rosewood fretboard
- 25.5inch Scale
- Edge-Zero II tremolo bridge
- Ibanez INF3 (H) neck PU
- Ibanez INF53 (S) middle PU
- Ibanez INF4 (H) bridge PU
- hardware color : Cosmo Black
- string : .009~.042 Round Wound (D'Addario:EXL120)
- color : BK (Black)

¥52,500 (本体価格 ¥50,000)

## NEW MODEL SPOT MODEL Left-handed



**WH**  
(White)

### RG450DXBL

- 3pc Wizard III Maple neck
- Basswood body
- Rosewood fretboard
- 25.5inch Scale
- Edge-Zero II tremolo bridge
- Ibanez INF3 (H) neck PU
- Ibanez INF53 (S) middle PU
- Ibanez INF4 (H) bridge PU
- hardware color : Black
- string : .009~.042 Round Wound (D'Addario:EXL120)
- color : WH (White)

¥66,150 (本体価格 ¥63,000)

## NEW MODEL



**TGB**  
(Transparent Gray Burst)

### RG421QM

- 3pc Wizard III Maple neck
- Quilted Maple top / Mahogany body
- Rosewood fretboard
- 25.5inch Scale
- Fixed bridge
- Ibanez INF3 (H) neck PU
- Ibanez INF4 (H) bridge PU
- hardware color : Cosmo Black
- string : .010~.046 Round Wound (D'Addario:EXL110)
- color : TGB (Transparent Gray Burst)  
TRB (Transparent Red Burst)



**TRB**  
(Transparent Red Burst)

¥52,500 (本体価格 ¥50,000)

## NEW MODEL



**MOL**  
(Mahogany Oil)

### RG421

- 3pc Wizard III Maple neck
- Mahogany body
- Rosewood fretboard
- 25.5inch Scale
- Fixed bridge
- Ibanez INF3 (H) neck PU
- Ibanez INF4 (H) bridge PU
- hardware color : Cosmo Black
- string : .010~.046 Round Wound (D'Addario:EXL110)
- color : MOL (Mahogany Oil)

¥47,250 (本体価格 ¥45,000)

## NEW MODEL SPOT MODEL 7-STRING



**BK**  
(Black)

### RG7420

- 3pc Wizard II-7 Maple/Walnut neck
- Basswood body
- Rosewood fretboard
- 25.5inch Scale
- Edge-Zero II-7 tremolo bridge
- Ibanez AH-7 (H) neck PU
- Ibanez AH-7 (H) bridge PU
- hardware color : Black
- string : .009~.054 Round Wound (D'Addario:EXL120-7)
- color : BK (Black)

¥68,250 (本体価格 ¥65,000)

## NEW MODEL 7-STRING



**BK**  
(Black)

### RG7421

- 3pc Wizard II-7 Maple/Walnut neck
- Basswood body
- Rosewood fretboard
- 25.5inch Scale
- Fixed bridge
- Ibanez AH-7 (H) neck PU
- Ibanez AH-7 (H) bridge PU
- hardware color : Black
- string : .010~.059 Round Wound (D'Addario:EXL110-7)
- color : BK (Black)  
WH (White)



**WH**  
(White)

¥63,000 (本体価格 ¥60,000)



## RGA

ハードテイル・ブリッジとアクティブ・ピックアップで武装したアーチド・トップ・ボディがパワーコード・ブレイから光速シェーディングまでリニアに対応するコンテンポラリーなシリーズ、RGA。

## NEW MODEL



**BK**  
(Black)  
¥84,000 (本体価格 ¥80,000)

## RGA42E

- 3pc Wizard III Maple neck
- Mahogany body
- Rosewood fretboard
- 25.5inch Scale
- Gibraltar Standard bridge
- EMG® 85 (H) neck PU
- EMG® 81 (H) bridge PU
- hardware color : Black
- string : .010~.046 Round Wound (D'Addario:EXL110)
- color : BK (Black)
- 9V乾電池(006P)×1で駆動

## NEW MODEL



**MOL**  
(Mahogany Oil)  
¥57,750 (本体価格 ¥55,000)

## RGA32

- 3pc Wizard III Maple neck
- Mahogany body
- Rosewood fretboard
- 25.5inch Scale
- Gibraltar Standard bridge
- CAP-LZ10 (H) neck PU
- CAP-LZ20 (H) bridge PU
- hardware color : Cosmo Black
- string : .010~.046 Round Wound (D'Addario:EXL110)
- color : MOL (Mahogany Oil)
- 単3乾電池×2で駆動

## 7-STRING



**BK**  
(Black)  
¥78,750 (本体価格 ¥75,000)

## RGA7

- 5pc Wizard II-7 Maple/Walnut neck
- Mahogany body
- Rosewood fretboard
- 25.5 inch Scale
- Gibraltar Standard-7 bridge
- CAP-LZ17 (H) neck PU
- CAP-LZ27 (H) bridge PU
- hardware color : Cosmo Black
- string : .010~.059 Round Wound (D'Addario:EXL110-7)
- color : BK (Black)
- 単3乾電池×2で駆動

## RGD

## SPOT MODEL 7-STRING



**BKF**  
(Black Flat)  
¥78,750 (本体価格 ¥75,000)

## RGD7421

- 5pc Wizard II-7 Maple/Walnut neck
- Basswood body
- Rosewood fretboard
- 26.5 inch Scale
- Gibraltar Standard-7 bridge
- CAP-VK17 (H) neck PU
- CAP-VK27 (H) bridge PU
- hardware color : Black
- string : .010~.059 Round Wound (D'Addario:EXL110-7)
- color : BKF (Black Flat)
- factory tuning : 1D, 2A, 3F, 4C, 5G, 6D, 7A

## S



**ATF**  
(Antique Burst Flat)  
¥99,750 (本体価格 ¥95,000)

## S770FM

- 3pc Wizard III Maple neck
- Flamed Maple top / Mahogany body
- Rosewood fretboard
- 25.5 inch Scale
- ZR tremolo bridge w/ ZPS2
- Ibanez INF1 (H) neck PU
- Ibanez INFS1 (S) middle PU
- Ibanez INF2 (H) bridge PU
- hardware color : Cosmo Black
- string : .009~.042 Round Wound (D'Addario:EXL120)
- color : ATF (Antique Burst Flat)



**NTF**  
(Natural Flat)  
¥99,750 (本体価格 ¥95,000)

## S770PB

- 3pc Wizard III Maple neck
- Poplar Burl top / Mahogany body
- Rosewood fretboard
- 25.5 inch Scale
- ZR tremolo bridge w/ ZPS2
- Ibanez INF1 (H) neck PU
- Ibanez INFS1 (S) middle PU
- Ibanez INF2 (H) bridge PU
- hardware color : Cosmo Black
- string : .009~.042 Round Wound (D'Addario:EXL120)
- color : NTF (Natural Flat)



**WK**  
(Weathered Black)  
¥73,500 (本体価格 ¥70,000)

## S420

- 3pc Wizard III Maple neck
- Mahogany body
- Rosewood fretboard
- 25.5 inch Scale
- ZR tremolo bridge w/ ZPS2
- Ibanez INF1 (H) neck PU
- Ibanez INF2 (H) bridge PU
- hardware color : Cosmo Black
- string : .009~.042 Round Wound (D'Addario:EXL120)
- color : WK (Weathered Black)

## NEW MODEL



**BK**  
(Black)  
¥63,000 (本体価格 ¥60,000)

## S421

- 3pc Wizard III Maple neck
- Mahogany body
- Rosewood fretboard
- 25.5inch Scale
- Gibraltar Standard bridge
- Ibanez INF1 (H) neck PU
- Ibanez INF2 (H) bridge PU
- hardware color : Cosmo Black
- string : .010~.046 Round Wound (D'Addario:EXL110)
- color : BK (Black)

## SPOT MODEL 7-STRING



**TGB**  
(Transparent Gray Burst)  
¥115,500 (本体価格 ¥110,000)

## S7420QM

- 3pc Wizard II-7 Maple/Walnut neck
- Quilted Maple top / Mahogany body
- Rosewood fretboard
- 25.5 inch Scale
- ZR-7 tremolo bridge w/ ZPS2
- Ibanez AH1-7 (H) neck PU
- Ibanez AH2-7 (H) bridge PU
- hardware color : Cosmo Black
- string : .010~.054 Round Wound (D'Addario:EXL110 + NW054)
- color : TGB (Transparent Gray Burst)



## SA

シンプルなコンストラクション、ノン・ロッキングのシンクロナイズド・タイプ・トレモロなどトラッドなテイストを残しながらも、サウンド、ルックス、操作性の全てにおいてモダン・クオリティで臨むSAシリーズ。

## NEW MODEL



**SPB**  
(Sapphire Blue)



**TGB**  
(Transparent Gray Burst)



**TRB**  
(Transparent Red Burst)  
¥66,150 (本体価格 ¥63,000)

## SA360QM

- 3pc SA Maple neck
- Quilted Maple top / Mahogany body
- Rosewood fretboard
- 25.5inch Scale
- SAT Pro II tremolo bridge
- Ibanez AHS1 (S) neck PU
- Ibanez AHS2 (S) middle PU
- Ibanez TDB1 (H) bridge PU
- hardware color : Chrome
- string : .009~.042 Round Wound (D'Addario:EXL120)
- color : SPB (Sapphire Blue)  
TGB (Transparent Gray Burst)  
TRB (Transparent Red Burst)

## NEW MODEL



**BBT**  
(Brown Burst)



**TGB**  
(Transparent Gray Burst)  
¥52,500 (本体価格 ¥50,000)

## SA160FM

- 3pc SA Maple neck
- Flamed Maple top / Mahogany body
- Rosewood fretboard
- 25.5inch Scale
- SAT Pro II tremolo bridge
- Ibanez AHS1 (S) neck PU
- Ibanez AHS2 (S) middle PU
- Ibanez STDH2 (H) bridge PU
- hardware color : Chrome
- string : .009~.042 Round Wound (D'Addario:EXL120)
- color : BBT (Brown Burst)  
TGB (Transparent Gray Burst)

## NEW MODEL Left-handed



**BBT**  
(Brown Burst)  
¥57,750 (本体価格 ¥55,000)

## SA160FML

- 3pc SA Maple neck
- Flamed Maple top / Mahogany body
- Rosewood fretboard
- 25.5inch Scale
- SAT Pro II tremolo bridge
- Ibanez AHS1 (S) neck PU
- Ibanez AHS2 (S) middle PU
- Ibanez STDH2 (H) bridge PU
- hardware color : Chrome
- string : .009~.042 Round Wound (D'Addario:EXL120)
- color : BBT (Brown Burst)

## FR

## NEW MODEL



**BBT**  
(Brown Burst)  
¥52,500 (本体価格 ¥50,000)

## FR420

- 3pc Wizard III Maple neck
- Ash body
- Rosewood fretboard
- 25.5inch Scale
- Tight-End bridge
- CAP-CCR1 (H) neck PU
- CAP-CCR2 (H) bridge PU
- hardware color : Chrome
- string : .010~.046 Round Wound (D'Addario:EXL110)
- color : BBT (Brown Burst)

## ARZ

ダウン・チューニングを視野に入れたスケール長と24フレット指板を採用したシングル・カットウェイ・ボディのARZ。



**BK**  
(Black)  
¥89,250 (本体価格 ¥85,000)

## ARZ700

- 3pc ARZ Mahogany/Maple set-in neck
- Mahogany body
- Rosewood fretboard
- 25.24 inch Scale
- Tight-Tune bridge & tailpiece
- EMG® 60 (H) neck PU
- EMG® 81 (H) bridge PU
- hardware color : Chrome
- string : .010~.046 Round Wound (D'Addario:EXL110)
- color : BK (Black)
- \*9V乾電池(O06P)×1で駆動

## 7-STRING



**BK**  
(Black)  
¥68,250 (本体価格 ¥65,000)

## ARZ307

- 3pc ARZ Mahogany/Maple set-in neck
- Mahogany body
- Rosewood fretboard
- 25.24 inch Scale
- Full Tune III-7 bridge & tailpiece
- Ibanez AH3-7 (H) neck PU
- Ibanez AH4-7 (H) bridge PU
- hardware color : Chrome
- string : .010~.059 Round Wound (D'Addario:EXL110-7)
- color : BK (Black)

## X

パワフルなトーン、ヘヴィなサウンド。シュレッド・プレイに必要な不可欠なプレイアビリティ。圧倒的な存在感を放つボディ・デザイン。それら全てを兼ね備えた生粋のメタル・ギア、X series。



**BK**  
(Black)  
¥89,250 (本体価格 ¥85,000)

## XP500FX

- 3pc Wizard III Maple neck
- Mahogany body
- Rosewood fretboard
- 25.5inch Scale
- Gibraltar Standard bridge
- DiMarzio® D Activator™ Neck (H) neck PU
- DiMarzio® D Activator™ Bridge (H) bridge PU
- hardware color : Cosmo Black
- string : .010~.046 Round Wound (D'Addario:EXL110)
- color : BK (Black)



NEW MODEL



**BK**  
(Black)  
¥94,500 (本体価格 ¥90,000)

IC500GB

- 3pc Iceman Mahogany/Maple set-in neck
- Mahogany body
- Rosewood fretboard
- 25.24inch Scale
- Gibraltar Standard bridge
- DiMarzio® D Activator™ Neck (H) neck PU
- DiMarzio® D Activator™ Bridge (H) bridge PU
- hardware color: Black
- string : .010~.046 Round Wound (D'Addario:EXL110)
- color : BK (Black)

NEW MODEL SPOT MODEL



**WH**  
(White)  
¥94,500 (本体価格 ¥90,000)

IC500BGB

- 3pc Iceman Mahogany/Maple set-in neck
- Mahogany body
- Rosewood fretboard
- 25.24inch Scale
- Gibraltar Standard bridge
- DiMarzio® D Activator™ Neck (H) neck PU
- DiMarzio® D Activator™ Bridge (H) bridge PU
- hardware color: Black
- string : .010~.046 Round Wound (D'Addario:EXL110)
- color : WH (White)

NEW MODEL 7-STRING



**BK**  
(Black)  
¥105,000 (本体価格 ¥100,000)

IC507GB

- 3pc Iceman-7 Mahogany/Maple set-in neck
- Mahogany body
- Rosewood fretboard
- 25.24inch Scale
- Gibraltar Standard-7 bridge
- DiMarzio® D Activator 7™ Neck (H) neck PU
- DiMarzio® D Activator 7™ Bridge (H) bridge PU
- hardware color: Black
- string : .010~.059 Round Wound (D'Addario:EXL110-7)
- color : BK (Black)

RG, RGA, S, SA, FR

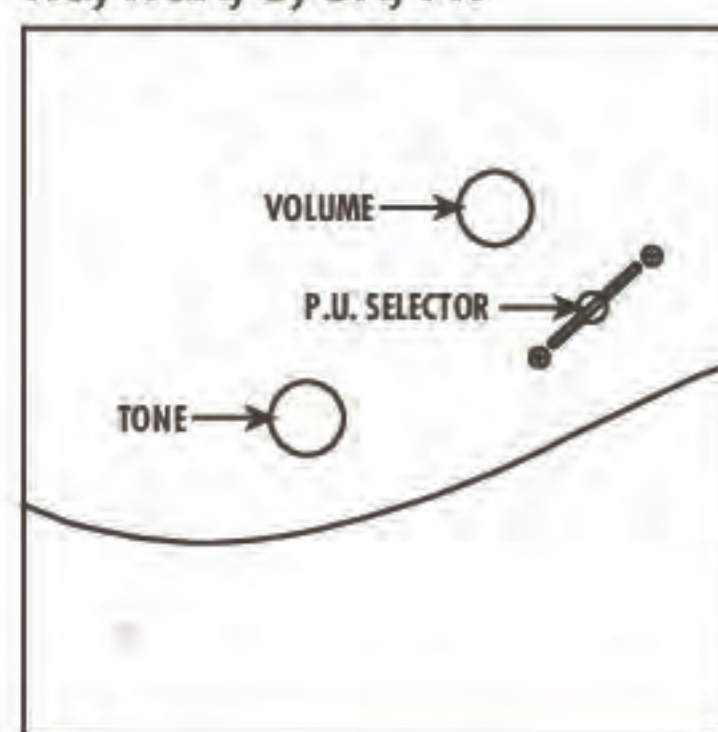

RGD

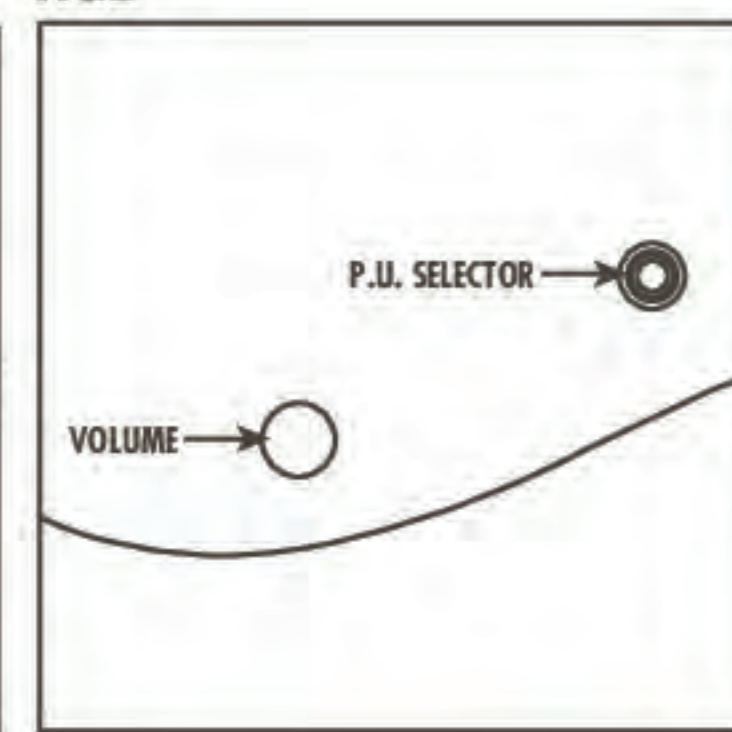

RGA7

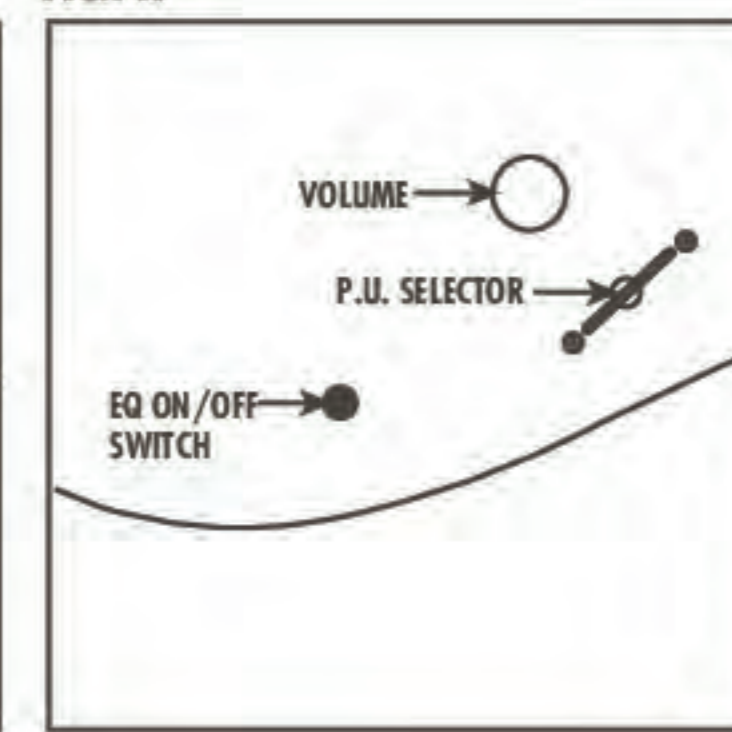

ARZ

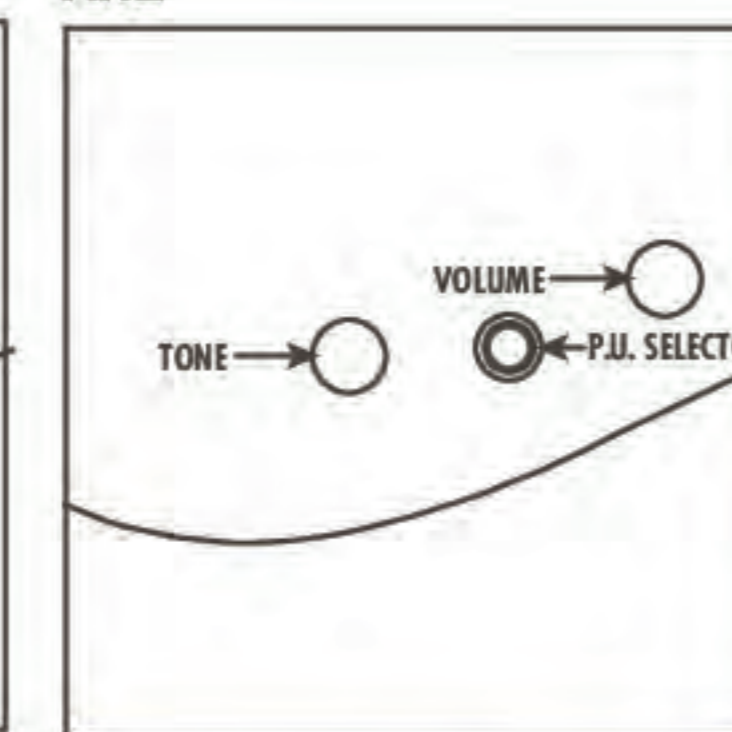

X, IC

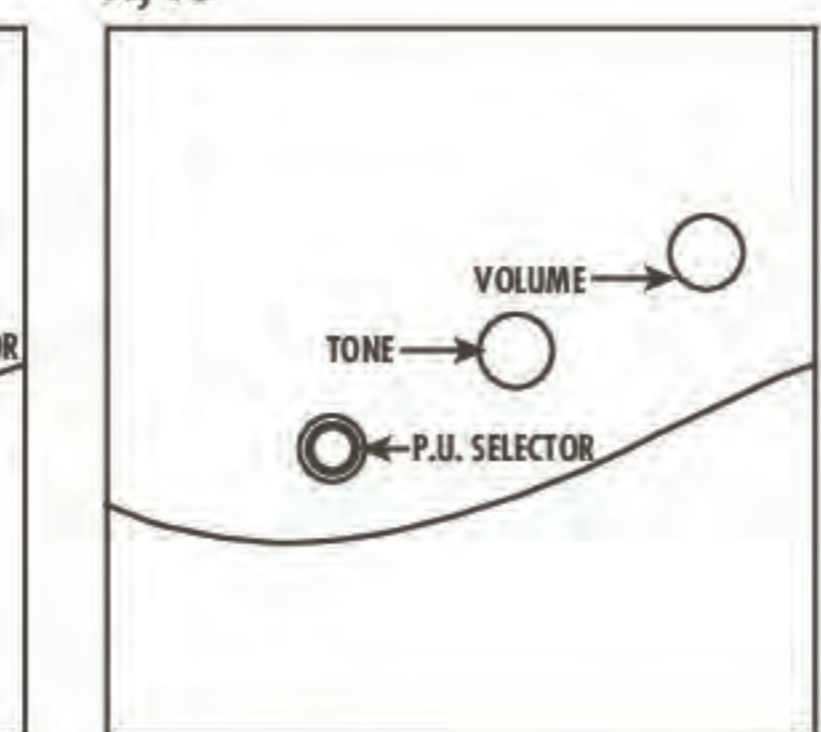

H-S-H (5WAY) RG, S

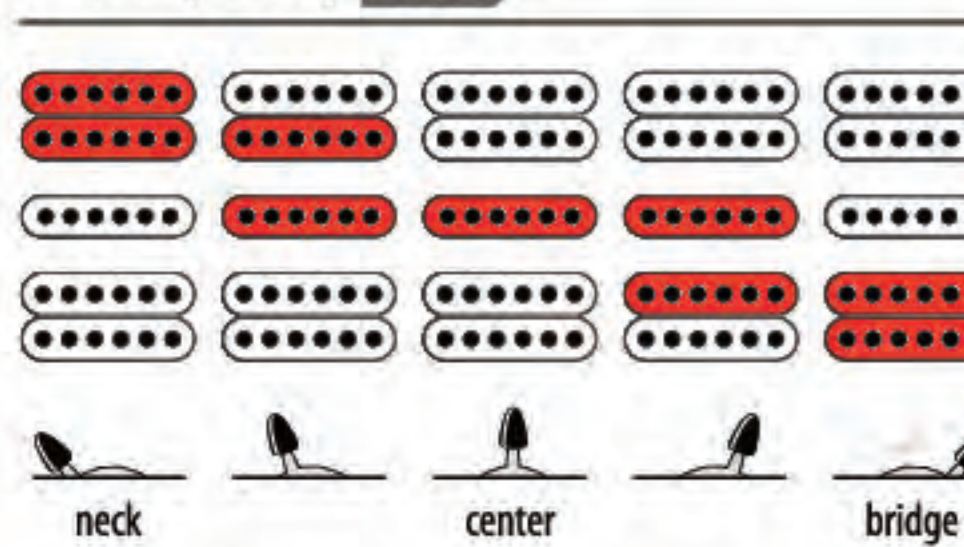

H-H (5WAY) RG, S

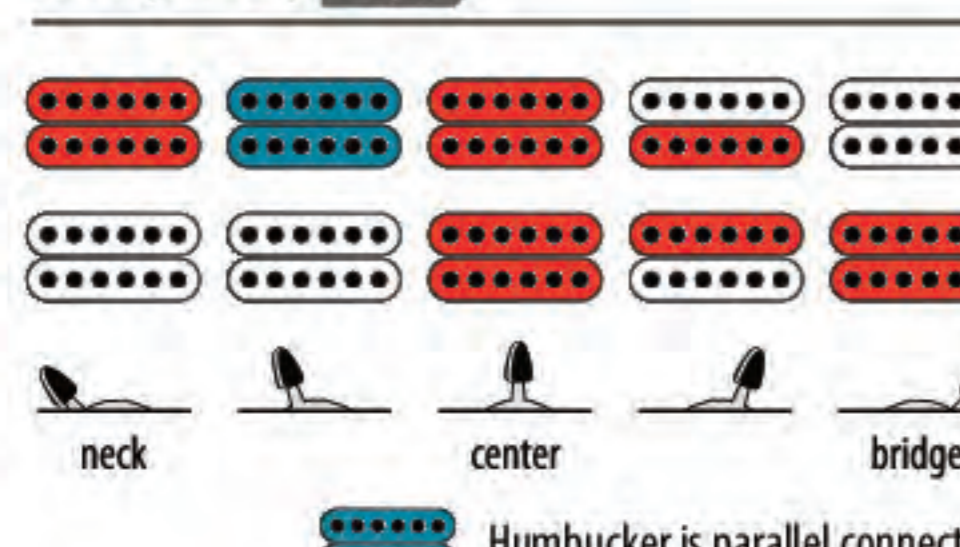

H-H (3WAY) RGA, RGD, ARZ, X, IC

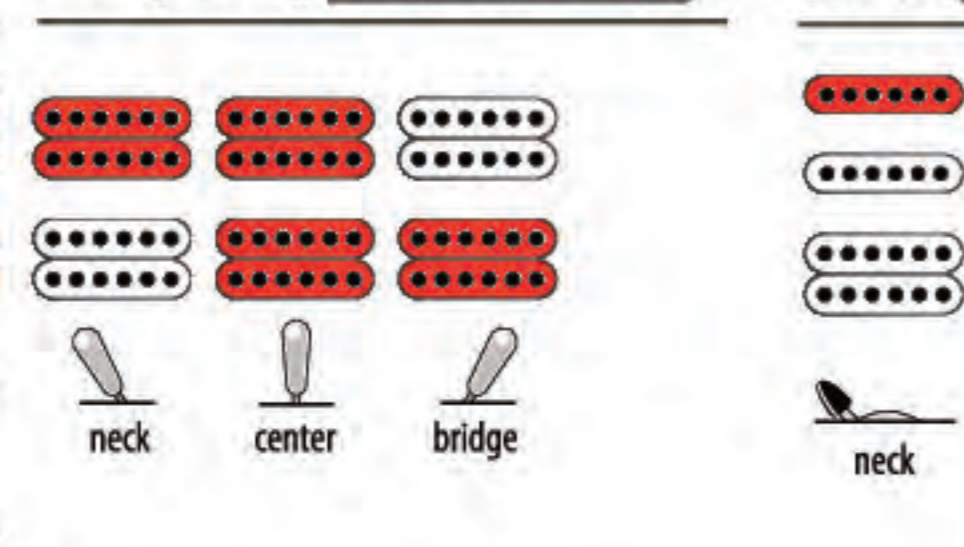

S-S-H (5WAY) SA160FM

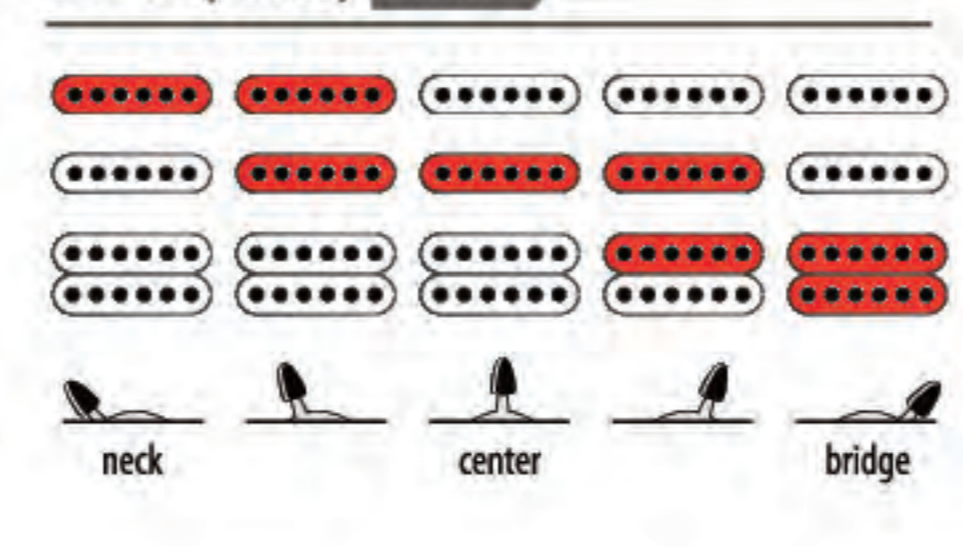

S-S-H (5WAY) SA360QM

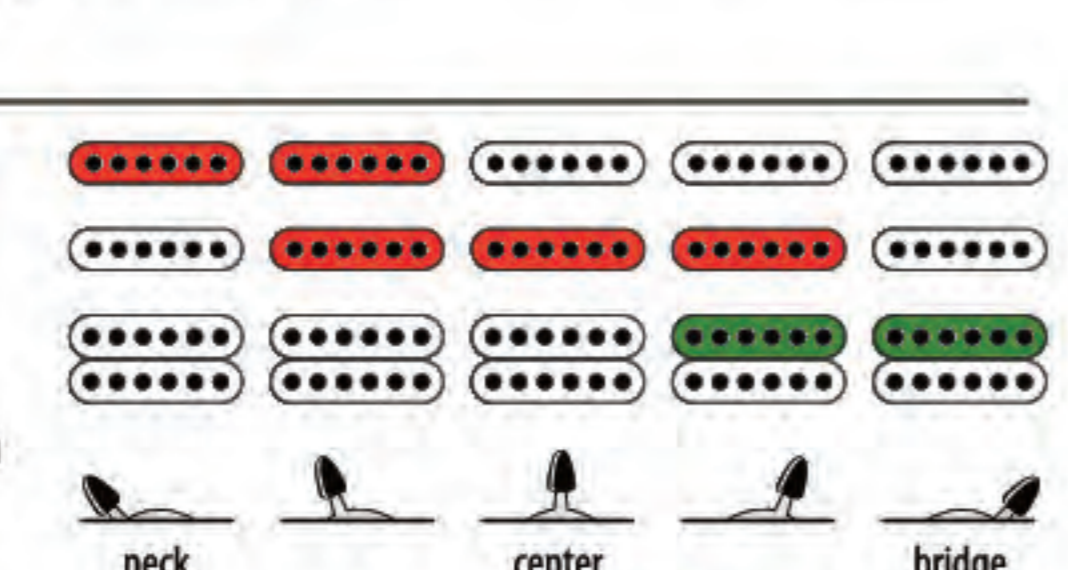
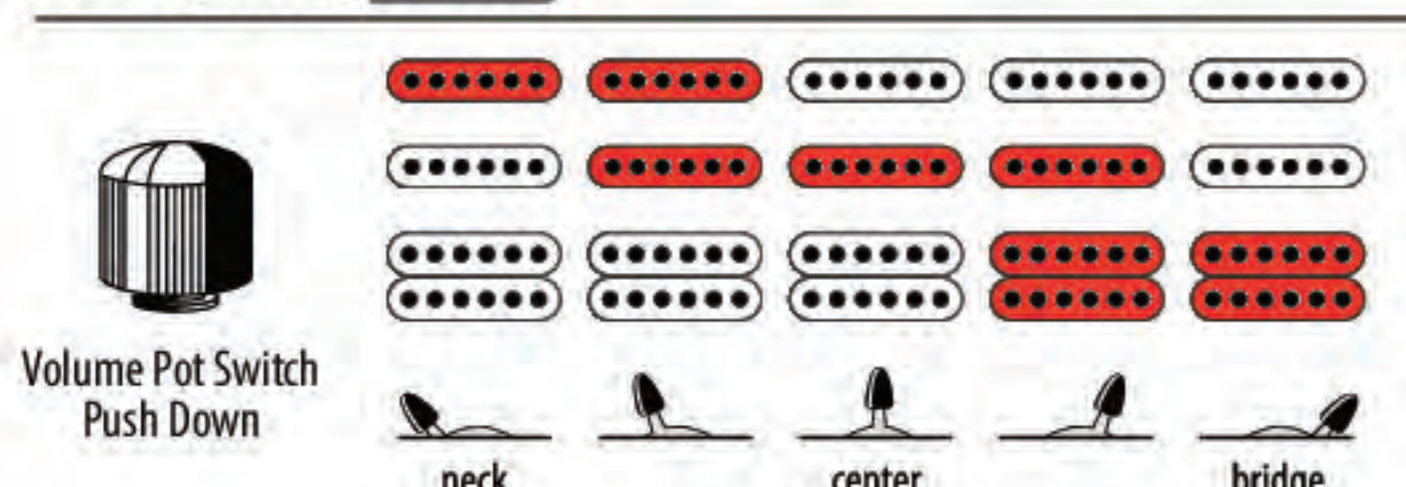

H-H (5WAY) FR

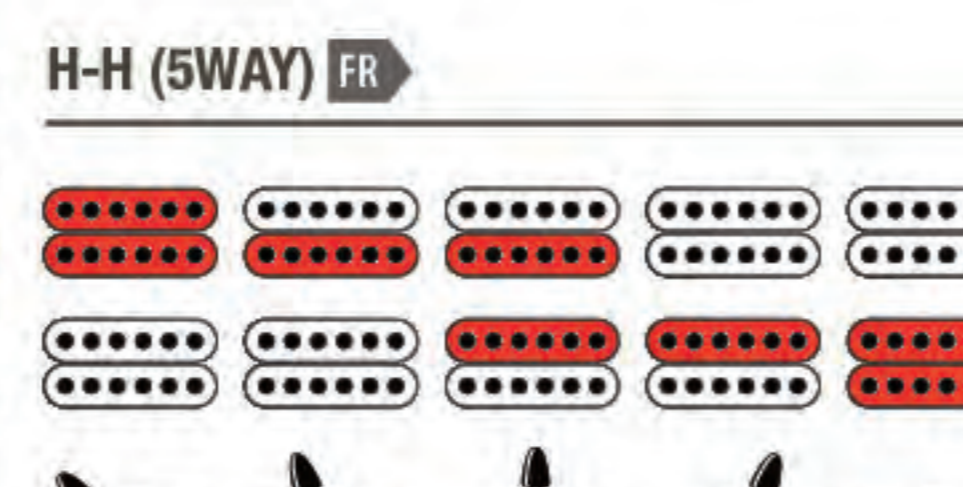

Volume Pot Switch Push Down

Volume Pot Switch Pull Up

Stacked Single Coil

# Steve Vai

## SIGNATURE MODELS

JEM / UV Control

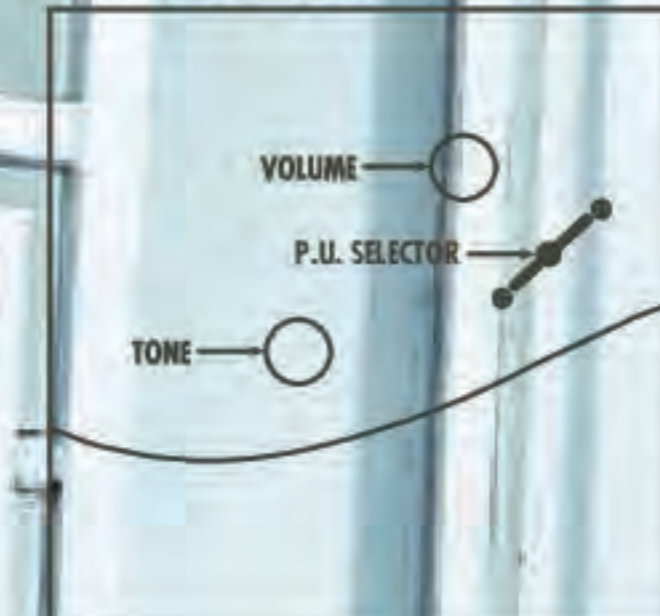

Switching System

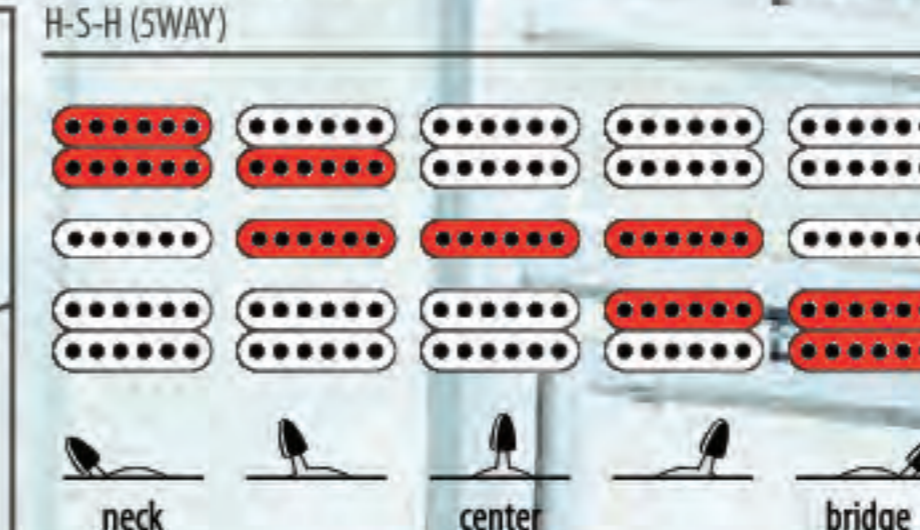

NEW MODEL Steve Vai SIGNATURE MODEL 7-STRING



**JEM7V7**  
Ultralite Tremolo Arm™  
**WH**  
(White)  
¥367,500 (本体価格 ¥350,000)

MADE IN JAPAN

- 5pc JEM7 Maple/Wenge neck
- Alder body
- Rosewood fretboard w/ Tree of Life position inlay, 21F~24F Scalloped
- 25.5inch Scale
- Lo-Pro Edge 7 tremolo bridge
- DiMarzio® Blaze™ Neck (H) neck PU
- DiMarzio® Blaze™ Middle (S) middle PU
- DiMarzio® Blaze™ Bridge (H) bridge PU
- hardware color: Gold
- string : .009~.054 Round Wound (D'Addario:EXL120-7)
- color : WH (White)
- includes : Hardshell case

NEW MODEL Steve Vai SIGNATURE MODEL 7-STRING PREMIUM



**UV70P**  
**BK**  
(Black)  
¥157,500 (本体価格 ¥150,000)

MADE IN JAPAN

- 5pc Wizard-7 Maple/Walnut neck w/ KTS™ TITANIUM rods
- American Basswood body
- Rosewood fretboard
- 25.5inch Scale
- Edge-Zero II-7 tremolo bridge
- DiMarzio® Blaze™ Neck (H) neck PU
- DiMarzio® Blaze™ Middle (S) middle PU
- DiMarzio® Blaze™ Bridge (H) bridge PU
- hardware color: Cosmo Black
- string : .009~.054 Round Wound (D'Addario:EXL120-7)
- color : BK (Black)
- includes : Gigcase

Steve Vai SIGNATURE MODEL



**JEM77**  
Ultralite Tremolo Arm™  
**FP2**  
(Floral Pattern 2)  
¥404,250 (本体価格 ¥385,000)

MADE IN JAPAN

- 5pc JEM Maple/Walnut neck
- Basswood body
- Rosewood fretboard w/ Tree of Life position inlay, 21F~24F Scalloped
- 25.5 inch Scale
- Edge tremolo bridge
- DiMarzio® Evolution® Neck (H) neck PU
- DiMarzio® Evolution® (S) middle PU
- DiMarzio® Evo 2™ Bridge (H) bridge PU
- hardware color: Chrome
- string : .009~.042 Round Wound (D'Addario:EXL120)
- color : FP2 (Floral Pattern 2)
- includes : Hardshell case

Steve Vai SIGNATURE MODEL



**JEM7V**  
Ultralite Tremolo Arm™  
**WH**  
(White)  
¥341,250 (本体価格 ¥325,000)

MADE IN JAPAN

- 5pc JEM Maple/Walnut neck
- Alder body
- Rosewood fretboard w/ Tree of Life position inlay, 21F~24F Scalloped
- 25.5 inch Scale
- Edge tremolo bridge
- DiMarzio® Evolution® Neck (H) neck PU
- DiMarzio® Evolution® (S) middle PU
- DiMarzio® Evolution® Bridge (H) bridge PU
- hardware color: Gold
- string : .009~.042 Round Wound (D'Addario:EXL120)
- color : WH (White)
- includes : Hardshell case



Steve Vai SIGNATURE MODEL PREMIUM



**SFG**  
(Sea Foam Green)  
¥178,500 (本体価格 ¥170,000)

JEM70V

- 5pc Wizard Maple/Walnut neck w/ KTS™ TITANIUM rods
- American Basswood body
- Rosewood fretboard w/ Tree of Life position inlay
- 25.5 inch Scale
- Edge tremolo bridge
- DiMarzio® Evolution® Neck (H) neck PU
- DiMarzio® Evolution® (S) middle PU
- DiMarzio® Evolution® Bridge (H) bridge PU
- hardware color: Chrome
- string: .009~.042 Round Wound (D'Addario:EXL120)
- color: SFG (Sea Foam Green)
- includes: Gigcase

Joe Satriani SIGNATURE MODEL



Ultralite Tremolo Arm™  
**CA**  
(Candy Apple)  
¥241,500 (本体価格 ¥230,000)

JS1200

MADE IN JAPAN

- 1pc JS Maple neck
- Basswood body
- Rosewood fretboard
- 25.5 inch Scale
- Edge tremolo bridge
- DiMarzio® PAF Joe™ (H) neck PU
- DiMarzio® FRED® (H) bridge PU
- hardware color: Chrome
- string: .009~.042 Round Wound (D'Addario:EXL120)
- color: CA (Candy Apple)
- includes: Hardshell case

NEW MODEL Joe Satriani SIGNATURE MODEL PREMIUM



**CA**  
(Candy Apple)  
¥162,750 (本体価格 ¥155,000)

JS24P

- 3pc JS Maple/Bubinga neck w/ KTS™ TITANIUM rods
- American Basswood body
- Rosewood fretboard
- 25.5 inch Scale
- Edge tremolo bridge
- DiMarzio® The Chopper™ (H) neck PU
- DiMarzio® Mo' Joe™ (H) bridge PU
- hardware color: Chrome
- string: .009~.042 Round Wound (D'Addario:EXL120)
- color: CA (Candy Apple)
- includes: Gigcase

Joe Satriani SIGNATURE MODELS

JS Control



JS2400 Switching System H-H (3WAY)



JS1200 Switching System H-H (3WAY)

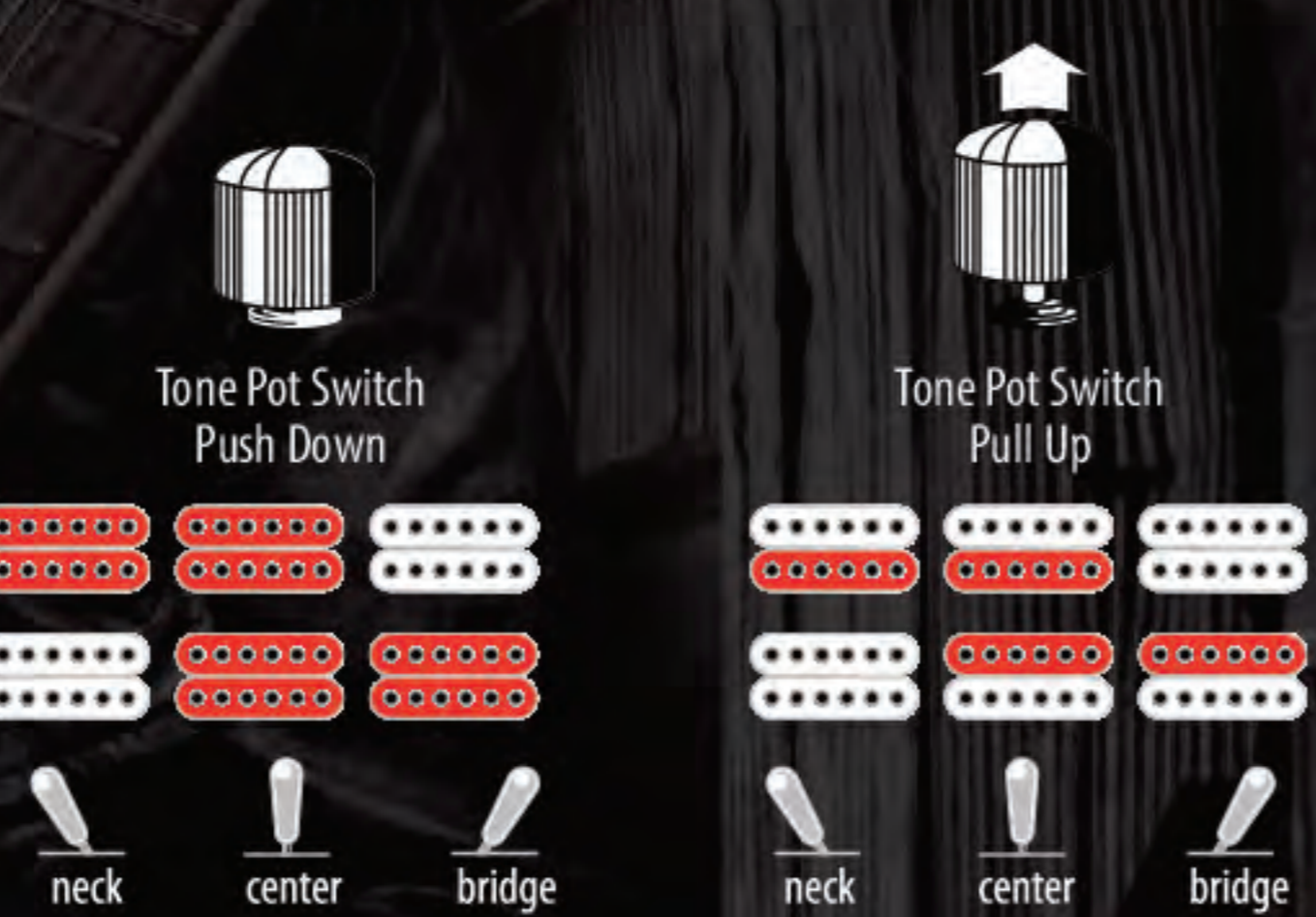

NEW MODEL Joe Satriani SIGNATURE MODEL



Ultralite Tremolo Arm™  
**MCO**  
(Muscle Car Orange)  
¥304,500 (本体価格 ¥290,000)

JS2410

MADE IN JAPAN

- 3pc JS Maple/Bubinga neck
- Alder body
- Rosewood fretboard
- 25.5 inch Scale
- Edge tremolo bridge
- DiMarzio® Satch Track™ (H) neck PU
- DiMarzio® Mo' Joe™ (H) bridge PU
- hardware color: Chrome
- string: .009~.042 Round Wound (D'Addario:EXL120)
- color: MCO (Muscle Car Orange)
- includes: Hardshell case

Switching System H-H (SWAY)

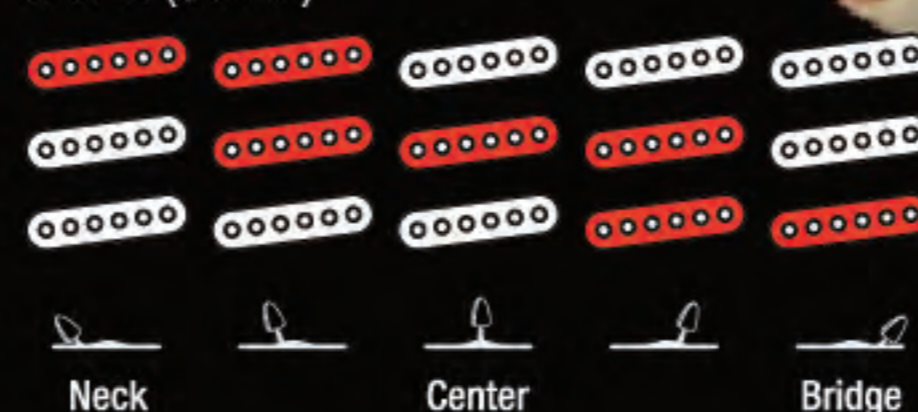

Joe Satriani SIGNATURE MODEL



Ultralite Tremolo Arm™  
**WH**  
(White)  
¥273,000 (本体価格 ¥260,000)

JS2400

MADE IN JAPAN

- 1pc JS Maple neck
- Basswood body
- Rosewood fretboard
- 25.5 inch Scale
- Edge tremolo bridge
- DiMarzio® Pro Track™ (H) neck PU
- DiMarzio® Mo' Joe™ (H) bridge PU
- hardware color: Chrome
- string: .009~.042 Round Wound (D'Addario:EXL120)
- color: WH (White)
- includes: Hardshell case

Paul Gilbert SIGNATURE MODEL



**TR**  
(Transparent Red)  
¥141,750 (本体価格 ¥135,000)

FRM100GB

- 3pc FRM Mahogany/Maple set-in neck
- Mahogany body
- Rosewood fretboard
- 24.75 inch Scale
- Tight-Tune bridge & tailpiece
- DiMarzio® Injector™ Neck (H) neck PU
- DiMarzio® Area 67™ (H) middle PU
- DiMarzio® Injector™ Bridge (H) bridge PU
- hardware color: Chrome
- string: .010~.046 Round Wound (D'Addario:EXL110)
- color: TR (Transparent Red)
- includes: Gigcase

FRM Control

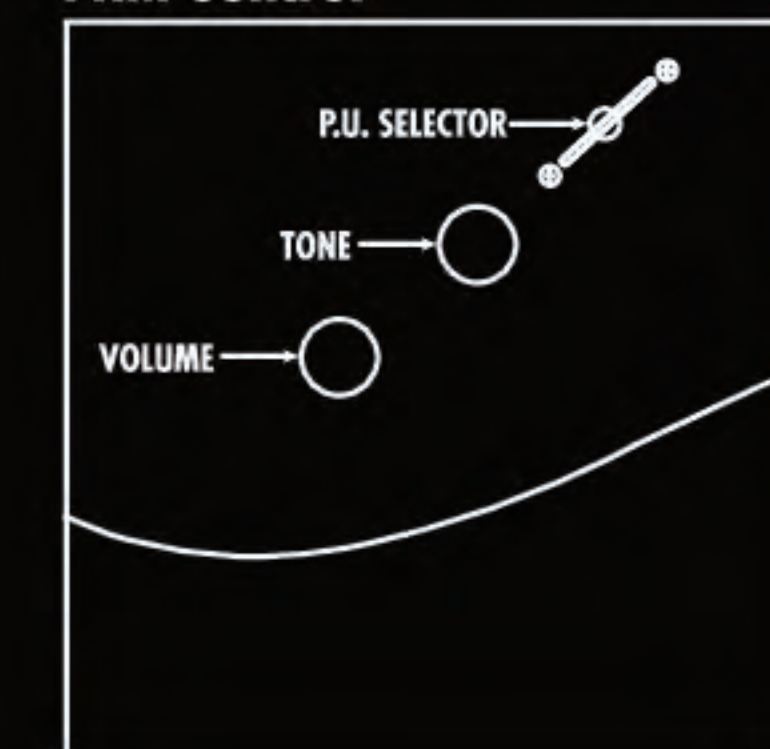

Paul Gilbert SIGNATURE MODEL





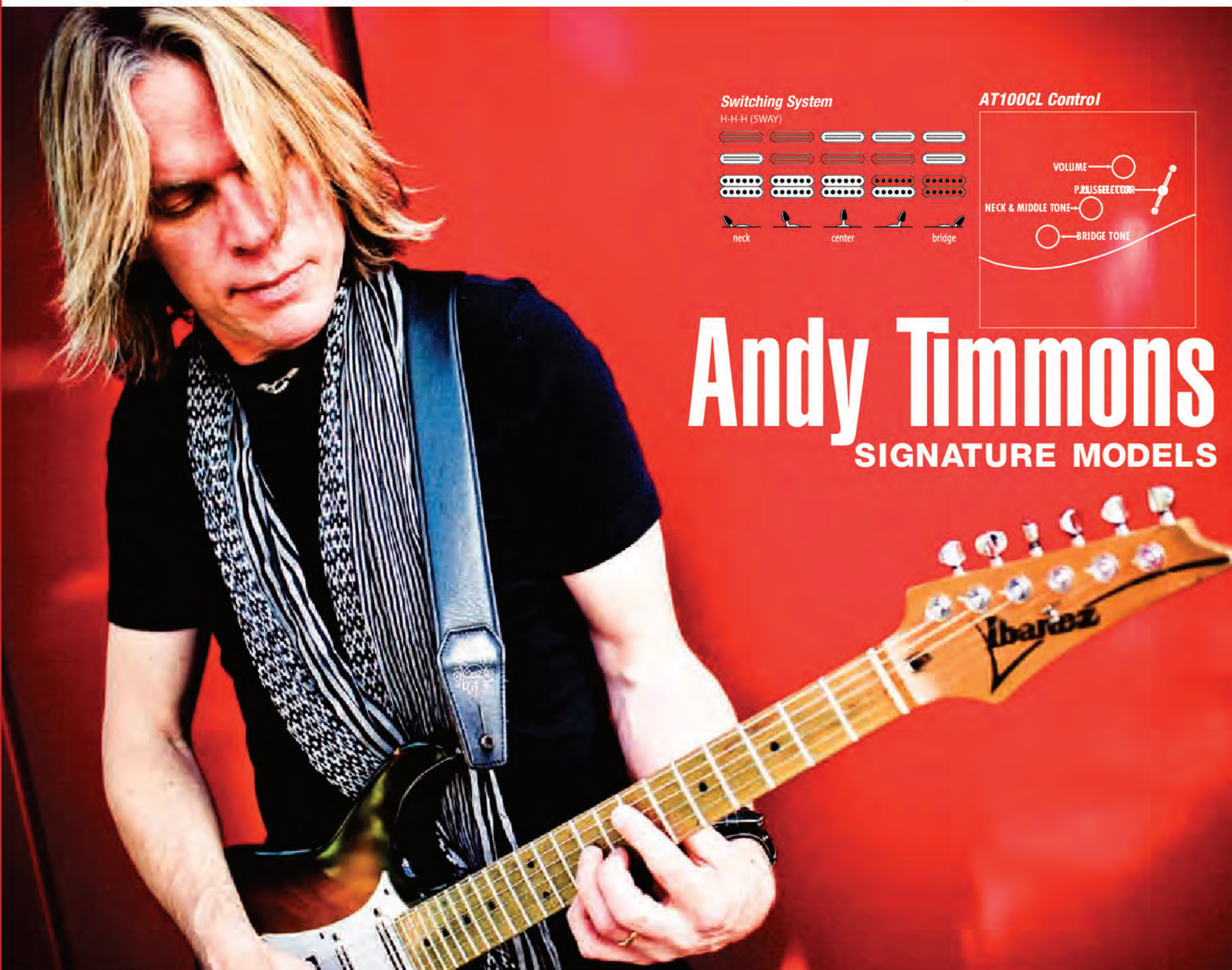

# Andy Timmons

## SIGNATURE MODELS

### Switching System

H-H (3WAY)

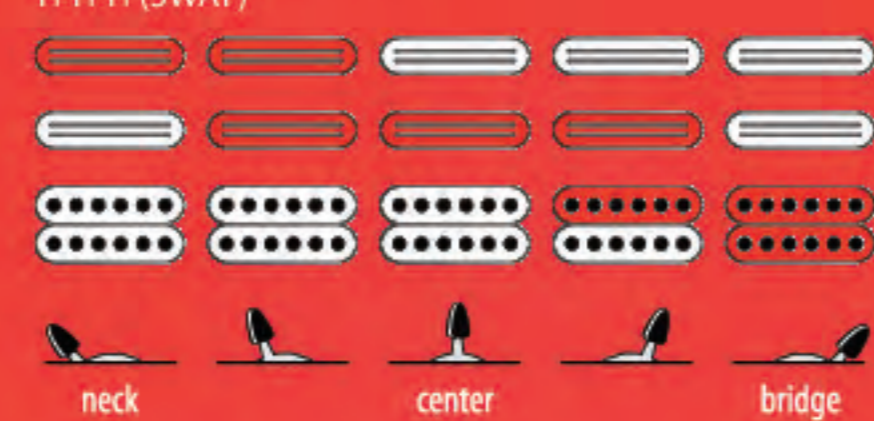

### AT100CL Control

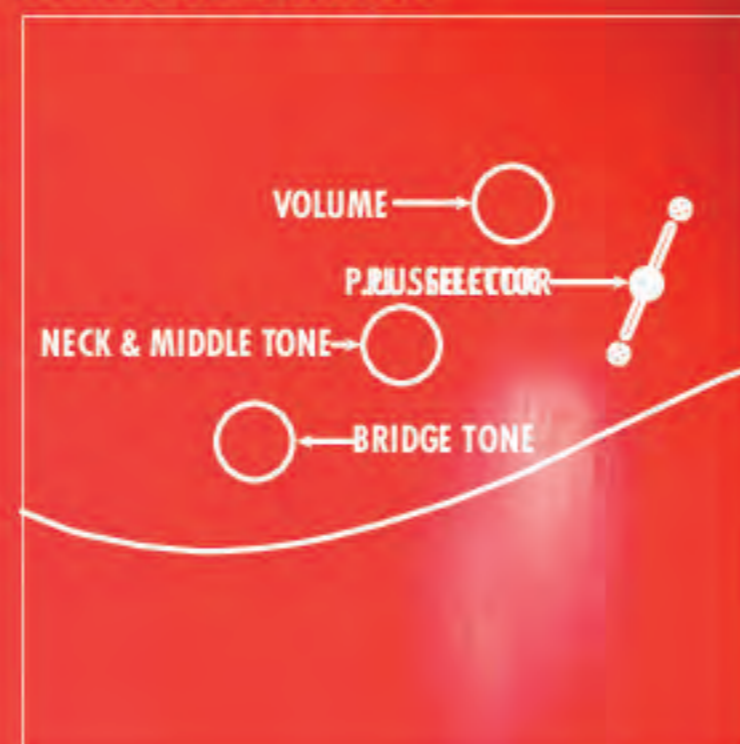

### Andy Timmons SIGNATURE MODEL



SB (Sunburst) ¥299,250 (本体価格 ¥285,000)

### AT100CL

MADE IN JAPAN

- 1pc AT Maple neck
- Alder body
- Maple fretboard
- 25.5 inch Scale
- Wilkinson® Gotoh® VSVG bridge
- DiMarzio® The Cruiser® Neck (H) neck PU
- DiMarzio® The Cruiser® Neck (H) middle PU
- DiMarzio® AT-1™ (H) bridge PU
- hardware color: Chrome
- string: .010~.046 Round Wound (D'Addario:EXL110)
- color: SB (Sunburst)
- includes: Hardshell case

### NEW MODEL Andy Timmons SIGNATURE MODEL PREMIUM



SB (Sunburst) ¥157,500 (本体価格 ¥150,000)

### AT10P

- 1pc AT Maple neck w/ KTS™ TITANIUM rods
- Alder body
- Maple fretboard
- 25.5 inch Scale
- Wilkinson® WV6-SB tremolo bridge
- DiMarzio® The Cruiser® (H) neck PU
- DiMarzio® The Cruiser® (H) middle PU
- DiMarzio® AT-1™ (H) bridge PU
- hardware color: Chrome
- string: .010~.046 Round Wound (D'Addario:EXL110)
- color: SB (Sunburst)
- includes: Gigcase

### Switching System

H-H (3WAY)



# Mick Thomson

## SIGNATURE MODEL

Photo by Paul Harries



### Mick Thomson SIGNATURE MODEL

### MTM100

- 5pc Wizard III Maple/Walnut neck-thru w/ KTS™ TITANIUM rods
- Mahogany wing body
- Rosewood fretboard w/ seven inlay
- 25.5 inch Scale
- FX Edge III bridge
- Seymour Duncan® Blackouts™ EMTY™ AHB3-n (H) Neck PU
- Seymour Duncan® Blackouts™ EMTY™ AHB3-b (H) bridge PU
- hardware color: Black
- string: .011~.049 Round Wound (D'Addario:EXL115)
- color: BK (Black)
- includes: Hardshell case
- factory tuning: 1C#, 2G#, 3E, 4B, 5F#, 6B
- \*9V乾電池(O06P)×1で駆動

BK (Black) ¥241,500 (本体価格 ¥230,000)

### MTM Control

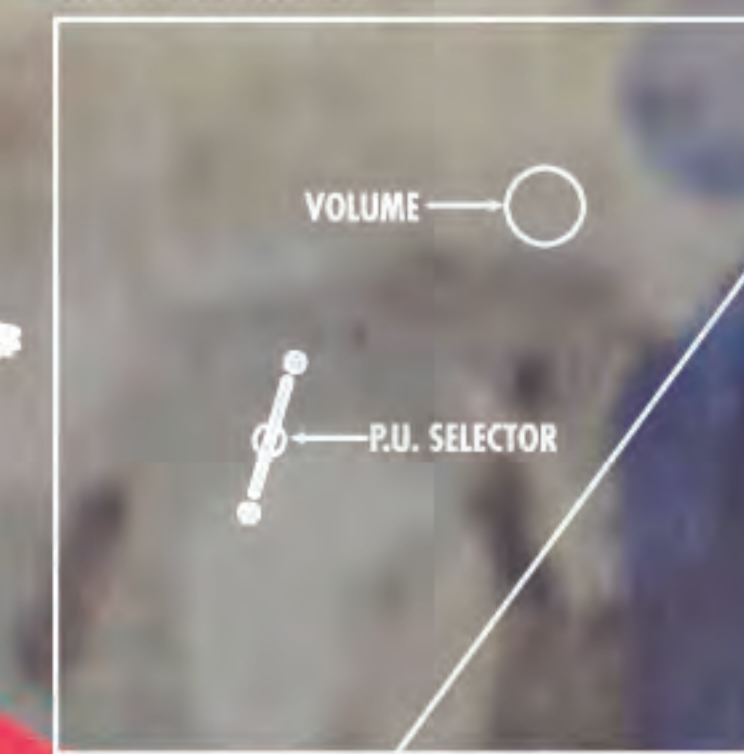

# Koehn

## Munky

### SIGNATURE MODEL

Photo by Sebastien Paquet

### Munky SIGNATURE MODEL 7-STRING



TFB (Tri Fade Burst) ¥262,500 (本体価格 ¥250,000)

### Switching System

H-H (3WAY)

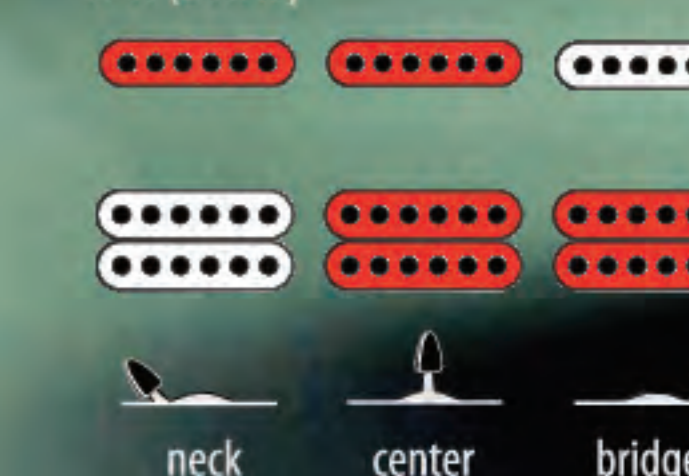

### APEX100 Control

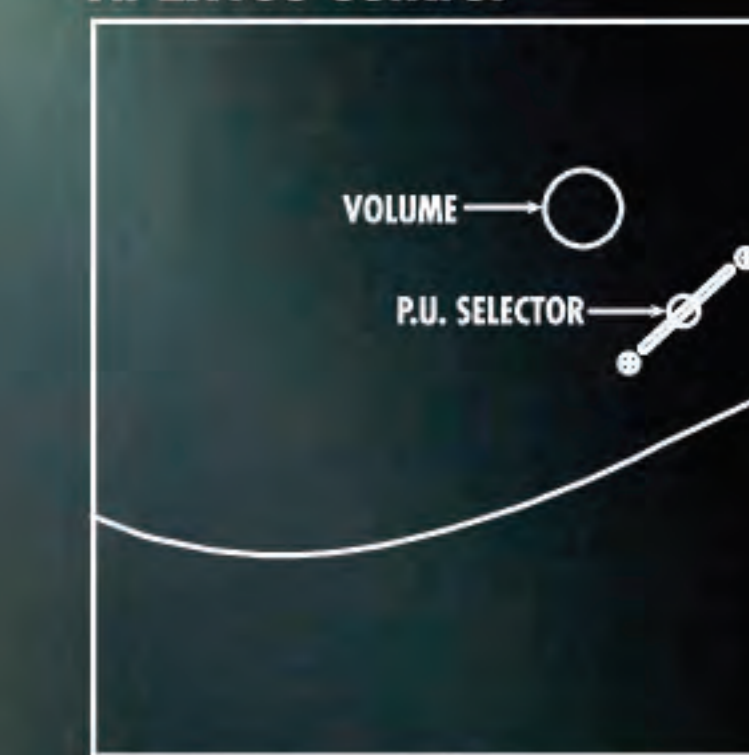

### APEX100

MADE IN JAPAN

- 5pc APEX Maple/Wenge neck
- Alder body
- Rosewood fretboard
- 25.5 inch Scale
- Lo-Pro Edge 7 tremolo bridge w/ U-bar
- DiMarzio® Blaze™ Middle (S) Neck PU
- DiMarzio® Blaze™ Bridge (H) bridge PU
- hardware color: Cosmo-Black
- string gauge: .010/.013/.017/.030/.042/.052/.060 (Dean Markley)
- color: TFB (Tri Fade Burst)
- includes: Hardshell case
- factory tuning: 1D, 2A, 3F, 4C, 5G, 6D, 7A
- \*通常のトレモロ・アームも付属します。



# THE OFFSPRING

## Noodles

### SIGNATURE MODEL

#### Switching System

H-H (3WAY)



neck center bridge

#### NDM Control

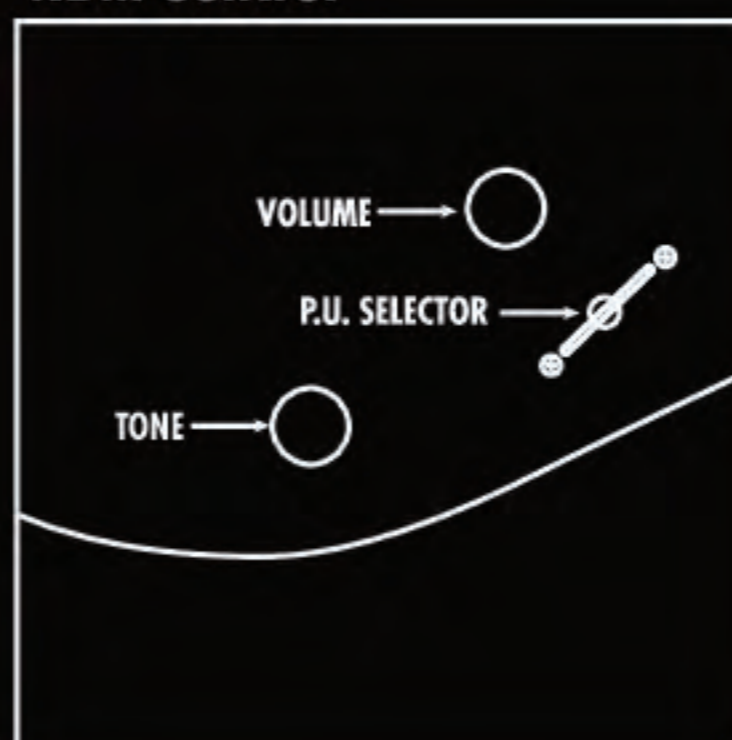

#### BBM Control

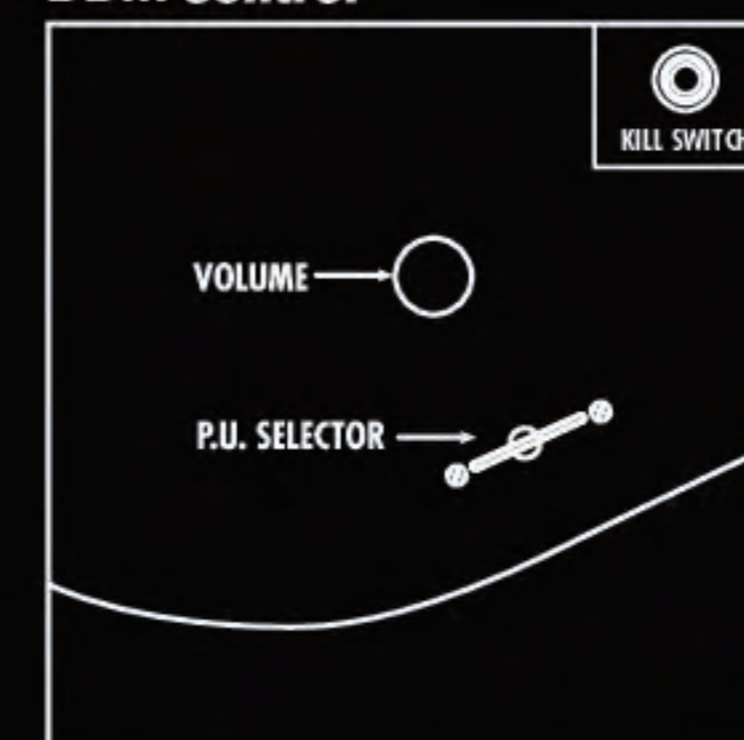

#### Switching System

H-H (3WAY)

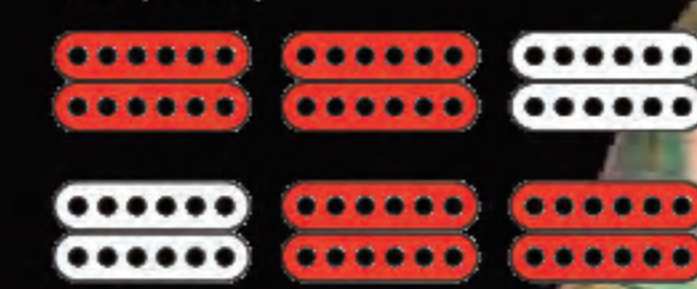

neck center bridge

# ASKING ALEXANDRIA

## Ben Bruce

### SIGNATURE MODEL

#### NEW MODEL Noodles SIGNATURE MODEL



¥136,500 (本体価格 ¥130,000)

#### NDM3

- 3pc NDM Maple neck
- Basswood body
- Rosewood fretboard
- 25.5inch Scale
- Fixed bridge
- Ibanez Std.-SS1 (S) neck PU
- Ibanez Std.-SS2 (S) bridge PU
- hardware color : Chrome
- string : .009~.042 Round Wound (D'Addario:EXL120)
- includes : Hardshell case

#### NEW MODEL BenBruce SIGNATURE MODEL



¥63,000 (本体価格 ¥60,000)

#### BBM1

- 3pc Wizard III Maple neck
- Mahogany body
- Rosewood fretboard
- 25.5inch Scale
- Tight-End bridge
- Ibanez INF3 (H) neck PU
- Ibanez INF4 (H) bridge PU
- hardware color : Cosmo Black
- string : .010~.046 Round Wound (D'Addario:EXL110)
- factory tuning : 1E, 2B, 3G, 4D, 5A, 6D

# MESHUGGAH

## SIGNATURE MODEL

Mårten Hagström

Fredrik Thordendal

#### M8M Control

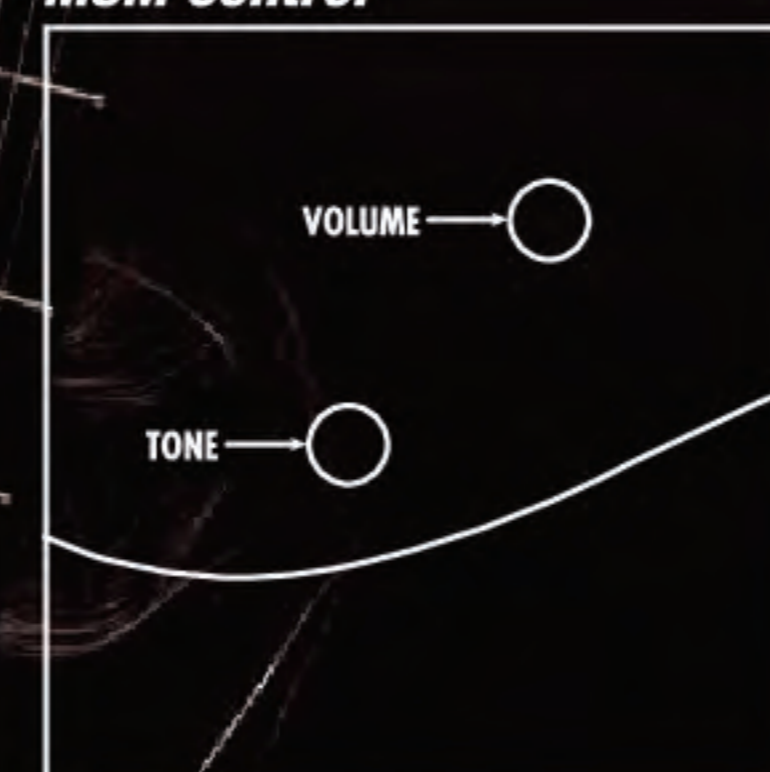

#### Meshuggah SIGNATURE MODEL 8-STRING



¥787,500 (本体価格 ¥750,000)

受注生産品

#### M8M

MADE IN JAPAN

- 5pc M8M Maple/Bubinga neck-thru
- Alder wing body
- Rosewood fretboard
- 29.4 inch Scale
- FX Edge III-8 bridge
- Lundgren Model M8 (H) bridge PU
- hardware color : Black
- string gauge : .009/.011/.016/.026/.036/.046/.052/.070 (JimDunlop)
- includes : Hardshell case
- factory tuning : 1D#, 2A#, 3F#, 4C#, 5G#, 6D#, 7A#, 8F

# ASKING ALEXANDRIA

## Cameron Liddell

### SIGNATURE MODEL

#### NEW MODEL CameronLiddell SIGNATURE MODEL



¥63,000 (本体価格 ¥60,000)

#### CLM1

- 1pc CLM Mahogany set-in neck
- Mahogany body
- Rosewood fretboard
- 25.24inch Scale
- ART-1 bridge
- Quik Change III tailpiece
- Ibanez Std.H (H) bridge PU
- hardware color : Cosmo Black
- string : .010~.046 Round Wound (D'Addario:EXL110)
- factory tuning : 1E, 2B, 3G, 4D, 5A, 6D



EGEN Control

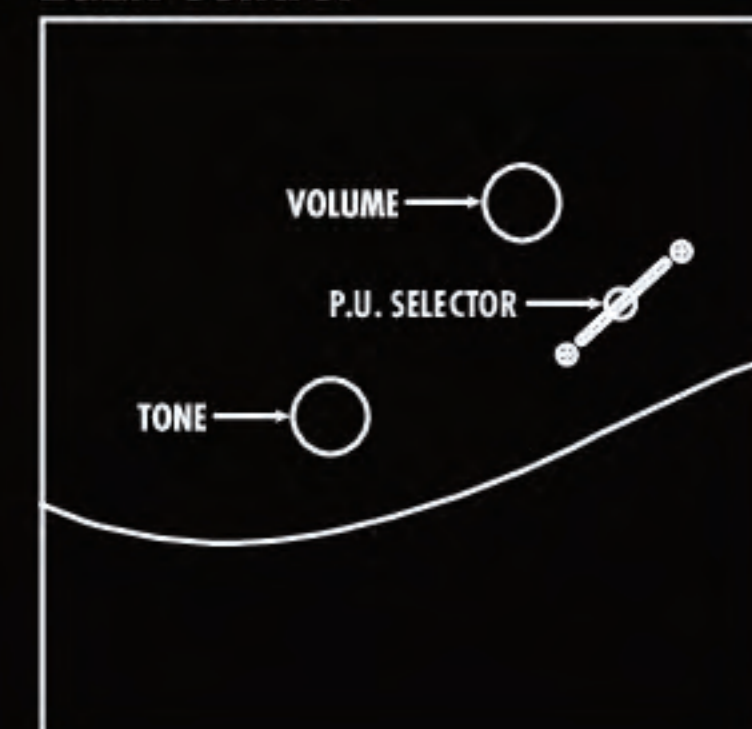

# Herman Li

SIGNATURE MODELS

Switching System  
H-S-H (5WAY)

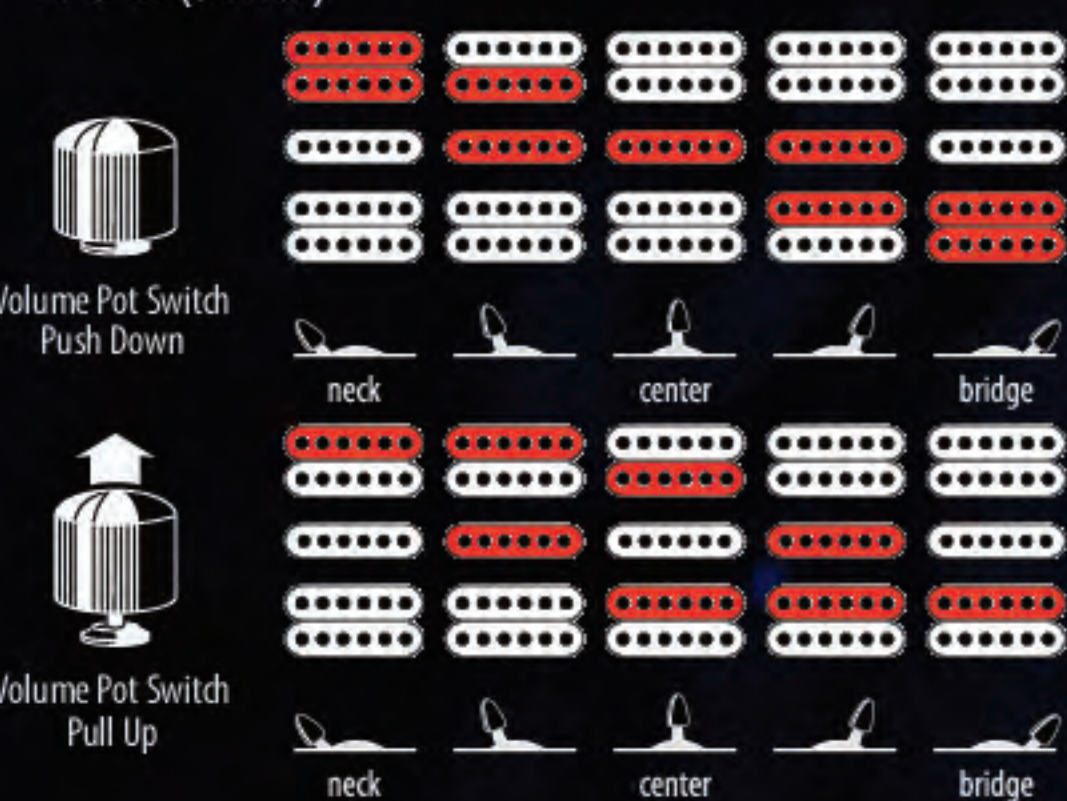

Herman Li SIGNATURE MODEL



**TVF**  
(Transparent Violet Flat)  
¥336,000 (本体価格 ¥320,000)

EGEN18

MADE IN JAPAN

- 5pc EGEN Maple/Walnut neck
- Flamed Maple top / Mahogany body
- Rosewood fretboard
- 25.5 inch Scale
- Edge-Zero tremolo bridge w/ ZPS3
- DiMarzio® HLM (H) neck PU
- DiMarzio® HLM (S) middle PU
- DiMarzio® HLM (H) bridge PU
- hardware color : Gold
- string : .009~.042 Round Wound (D'Addario:EXL120)
- color : TVF (Transparent Violet Flat)
- includes : Hardshell case

Herman Li SIGNATURE MODEL



**PLB**  
(Platinum Blonde)  
¥99,750 (本体価格 ¥95,000)

EGEN8

- 3pc Wizard III Maple neck
- Flamed Maple top / Mahogany body
- Rosewood fretboard
- 25.5 inch Scale
- Edge III tremolo bridge (Herman Li Special)
- Ibanez V7 (H) neck PU
- Ibanez S1 (S) middle PU
- Ibanez V8 (H) bridge PU
- hardware color : Gold
- string : .009~.042 Round Wound (D'Addario:EXL120)
- color : PLB (Platinum Blonde)

# Sam Totman

SIGNATURE MODEL



Switching System

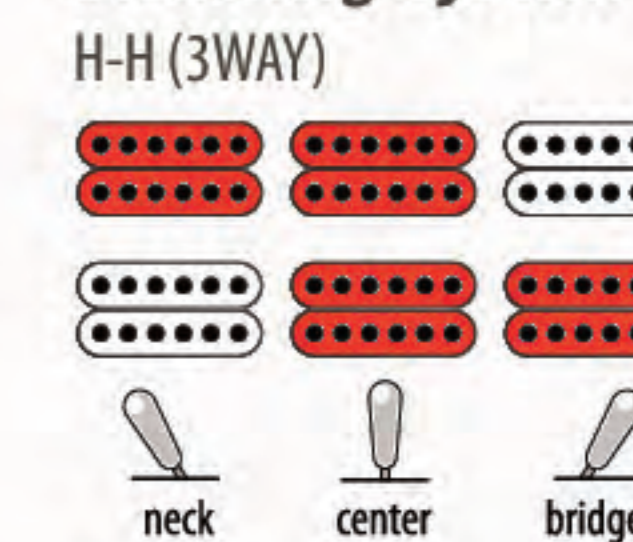

STM Control

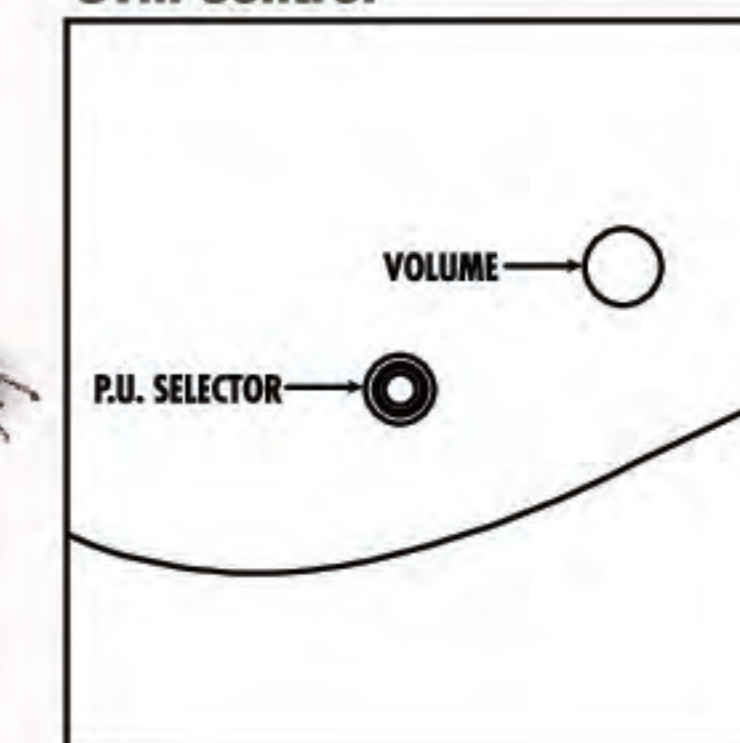

Sam Totman SIGNATURE MODEL



**SPB**  
(Sapphire Blue)  
¥141,750 (本体価格 ¥135,000)

STM2

- 5pc Wizard III Maple/Walnut neck-thru w/ KTS™ TITANIUM rods
- Flamed Maple top / Mahogany wing body
- Rosewood fretboard
- 25.5 inch Scale
- Edge III tremolo bridge
- DiMarzio® Evolution® Neck (H) neck PU
- DiMarzio® Evolution® Bridge (H) bridge PU
- hardware color : Chrome
- string : .009~.042 Round Wound (D'Addario:EXL120)
- color : SPB (Sapphire Blue)
- includes : Hardshell case

M8M Control

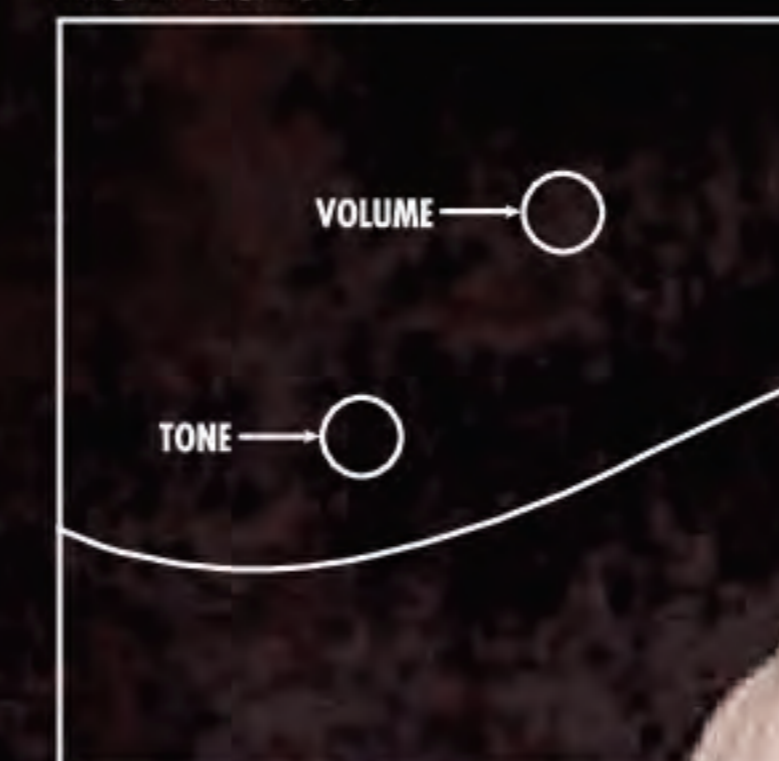

Switching System  
H-S-H (5WAY)

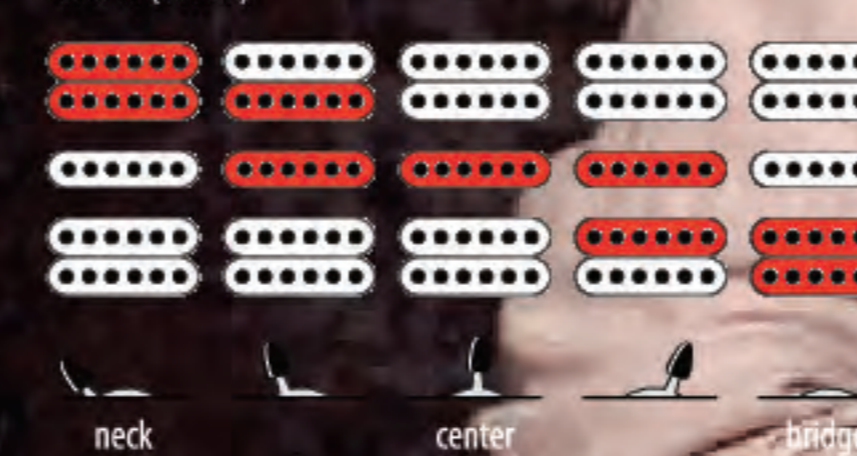

animals as leaders

# Tosin Abasi

SIGNATURE MODEL

NEW MODEL Tosin Abasi SIGNATURE MODEL 8-STRING



**TAM100**  
¥525,000 (本体価格 ¥500,000)

TAM100

MADE IN JAPAN

- 5pc TAM8 Wenge/Bubinga neck w/ KTS™ TITANIUM rods
- AAA Quilted Maple (4mm) top / Basswood (36mm) back body
- Wenge fretboard
- 27inch Scale
- FX Edge III-8 bridge
- DiMarzio® Ionizer 8™ Neck (H) neck PU
- DiMarzio® Ionizer 8™ Middle (H) middle PU
- DiMarzio® Ionizer 8™ Bridge (H) bridge PU
- hardware color : Gold
- string : .010~.074 Round Wound (D'Addario:EXL140-8)
- includes : Hardshell case
- factory tuning : 1E, 2B, 3E, 4A, 5D, 6G, 7B, 8E



# Hollow Body Guitars

## ARTSTAR

Ibanez ARTSTAR (アートスター) は、'70年代後半からGeorge BensonやJohn Scofield、Pat Methenyら数々のミュージシャンとともに築き上げたジャズ・ギターづくりのノウハウを受け継ぎ、Ibanezジャズ・ギターの新しい1ページを記すべく生まれたシリーズ。

### Switching System

H-H (3WAY)

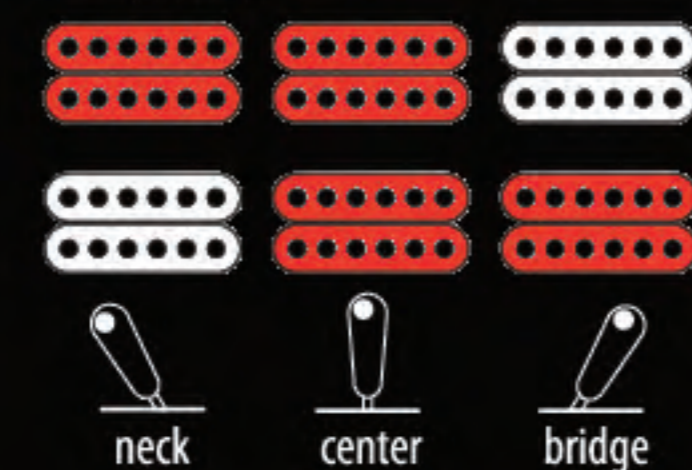

Tri-Sound SW (Neck PU)

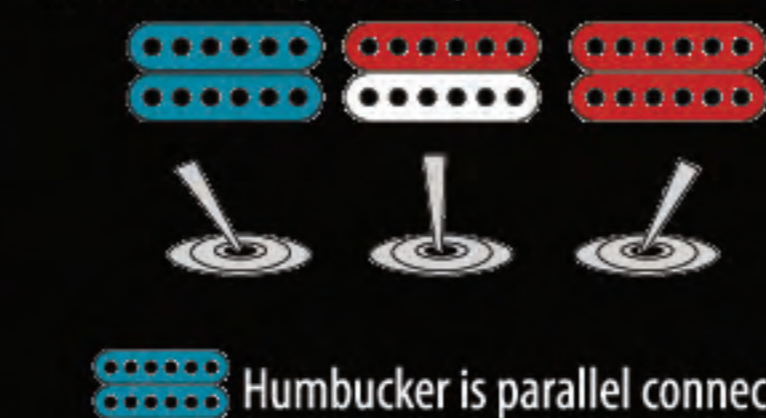

### Hollow Body Guitars Control

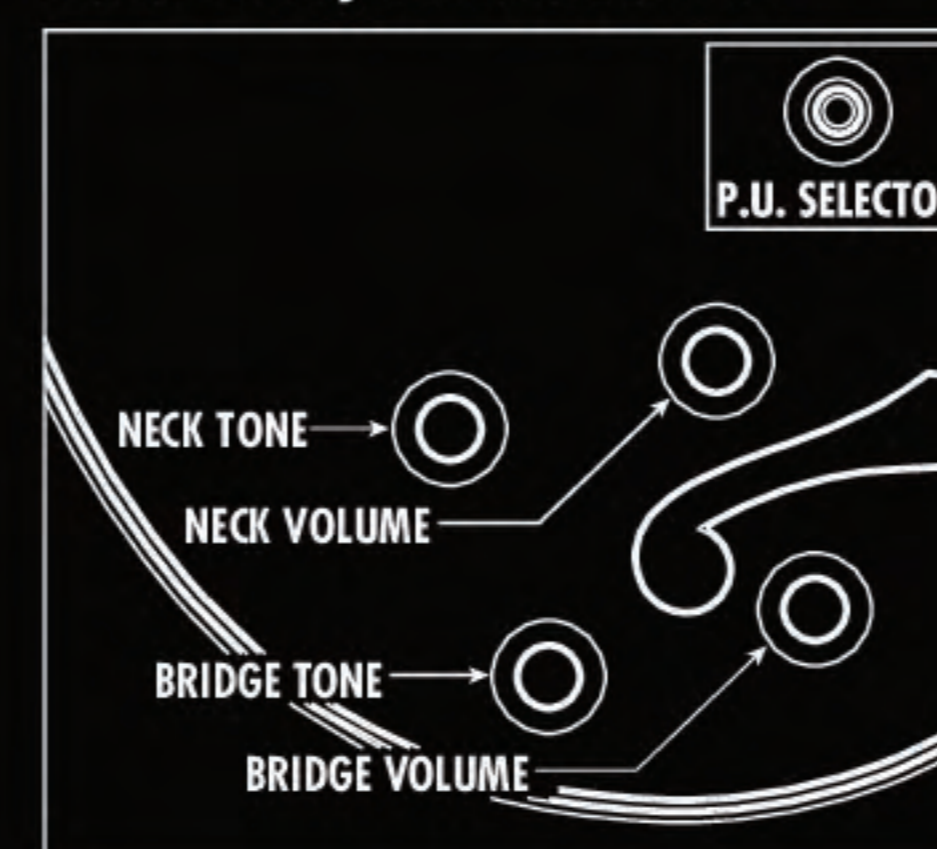

### SF301/AF151/AFJ91

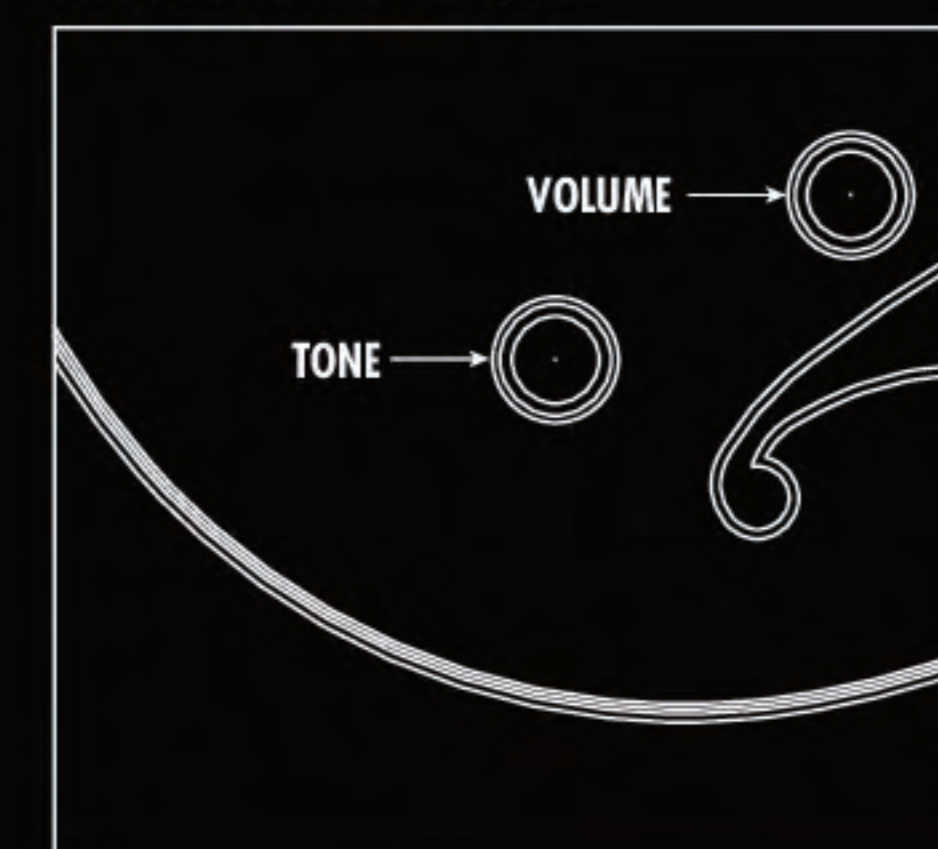

### ASF180/SAS300/AS153

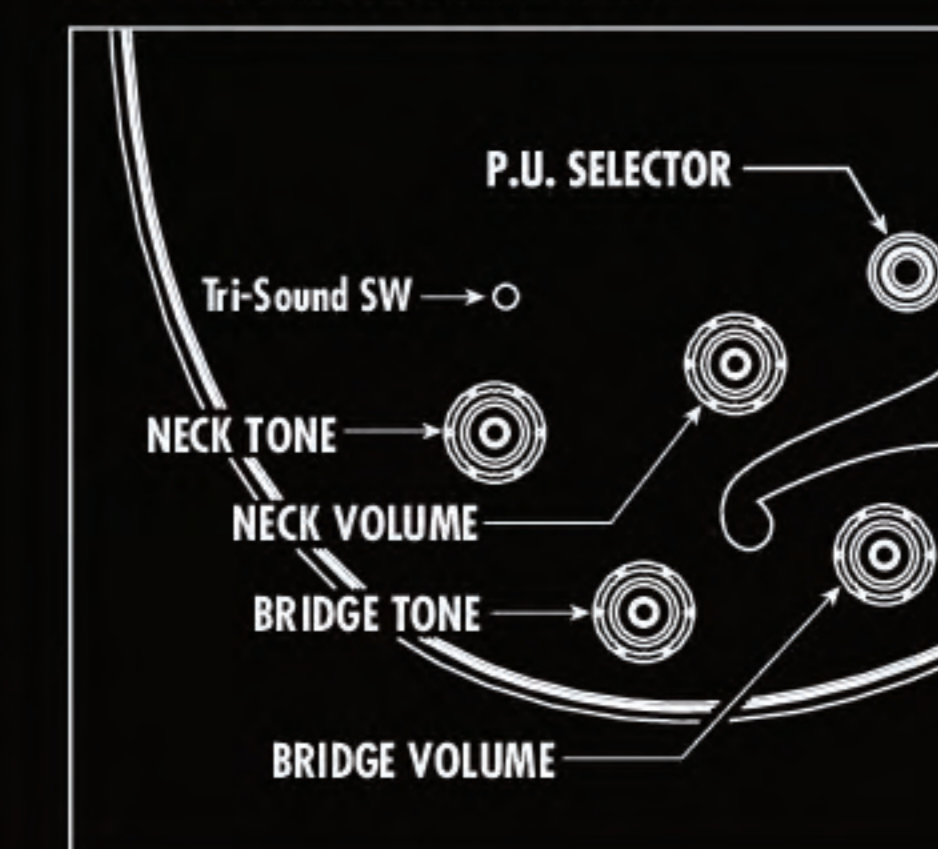

## NEW MODEL Full Hollow ARTSTAR



**AWB**  
(Aged Whiskey Burst)  
¥115,500 (本体価格 ¥110,000)

### AF155

- ARTSTAR 3pc Mahogany/Maple set-in neck
- Flamed Maple top/back/sides full-hollow body
- Ebony fretboard
- 24.7inch Scale
- ART-W wooden bridge
- VT06S tailpiece
- Ibanez Super 58 custom (H) neck PU
- Ibanez Super 58 custom (H) bridge PU
- hardware color : Gold
- string : .011~.050 Flat Wound (D'Addario:ECG24)
- color : AWB (Aged Whiskey Burst)
- includes : Hardshell case
- depth : 70mm at tail

## NEW MODEL Semi Hollow ARTSTAR



**AYS**  
(Antique Yellow Sunburst)  
¥115,500 (本体価格 ¥110,000)

### AS153

- ARTSTAR 3pc Mahogany/Maple set-in neck
- Flamed Maple top/back/sides semi-hollow body
- Ebony fretboard
- 24.7inch Scale
- ART-1 wooden bridge
- Quik Change III tailpiece
- Ibanez Super 58 custom (H) neck PU
- Ibanez Super 58 custom (H) bridge PU
- hardware color : Gold
- string : .010~.052 Round Wound (D'Addario:EXL140)
- color : AYS (Antique Yellow Sunburst)
- includes : Hardshell case
- depth : 43mm at tail



## NEW MODEL SPOT MODEL Full Hollow ARTSTAR



**BS**  
(Brown Sunburst)  
¥252,000 (本体価格 ¥240,000)

## AF180 MADE IN JAPAN

- ARTSTAR 5pc Maple/Mahogany set-in neck
- Maple top/back/sides full-hollow body
- Ebony fretboard
- 24.7inch Scale
- Ebony bridge
- AF Special tailpiece
- Ibanez Super 58 (H) neck PU
- Ibanez Super 58 (H) bridge PU
- hardware color : Gold
- string : .011~.050 Flat Wound (D'Addario:ECG24)
- color : BS (Brown Sunburst)
- includes : Hardshell case
- depth : 70mm at tail

## NEW MODEL Full Hollow ARTSTAR



**AWB**  
(Aged Whiskey Burst)  
¥115,500 (本体価格 ¥110,000)

## AF151

- ARTSTAR 3pc Mahogany/Maple set-in neck
- Flamed Maple top/back/sides full-hollow body
- Ebony fretboard
- 24.7inch Scale
- ART-W wooden bridge
- VT06S tailpiece
- Ibanez Super 58 custom (H) neck PU
- hardware color : Gold
- string : .011~.050 Flat Wound (D'Addario:ECG24)
- color : AWB (Aged Whiskey Burst)
- includes : Hardshell case
- depth : 70mm at tail

## NEW MODEL SPOT MODEL Full Hollow ARTSTAR



**AV**  
(Antique Violin)  
¥252,000 (本体価格 ¥240,000)

## ASF180 MADE IN JAPAN

- ARTSTAR 1pc Mahogany set-in neck
- Maple top/back/sides full-hollow body
- Ebony fretboard
- 24.7inch Scale
- Gotoh® 510BN bridge
- AFS Special tailpiece
- Ibanez Super 58 (H) neck PU
- Ibanez Super 58 (H) bridge PU
- hardware color : Gold
- string : .013~.052 Round Wound (D'Addario:PL013/016/022, NW032/042/052)
- color : AV (Antique Violin)
- includes : Hardshell case
- depth : 43mm at tail

## NEW MODEL Full Hollow



**SRD**  
(Sunset Red)  
¥78,750 (本体価格 ¥75,000)

## AFJ91

- Expressionist 3pc Mahogany/Maple set-in neck
- Spruce top / Flamed Maple back & sides full-hollow body
- Rosewood fretboard
- 24.7inch Scale
- ART-W bridge
- VT04 tailpiece
- Ibanez Super 58 custom (H) neck PU
- hardware color : Gold
- string : .011~.050 Flat Wound (D'Addario:ECG24)
- color : SRD (Sunset Red)
- depth : 70mm at tail

## NEW MODEL SPOT MODEL Full Hollow ARTSTAR



**VLS**  
(Violin Sunburst)  
¥157,500 (本体価格 ¥150,000)

## SAS300

- ARTSTAR 5pc Maple/Walnut set-in neck
- Solid Spruce top, Flamed Maple back/sides full-hollow body
- Ebony fretboard
- 24.7inch Scale
- ART-1 bridge
- VT06L tailpiece
- Ibanez Super 58 custom (H) neck PU
- Ibanez Super 58 custom (H) bridge PU
- hardware color : Gold
- string : .010~.052 Round Wound (D'Addario:EXL140)
- color : VLS (Violin Sunburst)
- includes : Hardshell case
- depth : 43mm at tail

## NEW MODEL Full Hollow



**VSB**  
(Vintage Sunburst)  
¥78,750 (本体価格 ¥75,000)

## AFJ95

- Expressionist 3pc Mahogany/Maple set-in neck
- Spruce top / Flamed Maple back & sides full-hollow body
- Rosewood fretboard
- 24.7inch Scale
- ART-W bridge
- VT06 tailpiece
- Ibanez Super 58 custom (H) neck PU
- Ibanez Super 58 custom (H) bridge PU
- hardware color : Gold
- string : .011~.050 Flat Wound (D'Addario:ECG24)
- color : VSB (Vintage Sunburst)
- depth : 70mm at tail

## NEW MODEL SPOT MODEL Full Hollow ARTSTAR



**VN**  
(Vintage Natural)  
¥157,500 (本体価格 ¥150,000)

## SF301

- ARTSTAR 5pc Maple/Walnut set-in neck
- Solid Spruce top, Flamed Maple back/sides full-hollow body
- Ebony fretboard
- 24.7inch Scale
- ART-W bridge
- VT06S tailpiece
- Ibanez Floating Mini Humbucker (H) neck PU
- hardware color : Gold
- string : .011~.050 Flat Wound (D'Addario:ECG24)
- color : VN (Vintage Natural)
- includes : Hardshell case
- depth : 80mm at tail

## NEW MODEL Full Hollow 7-STRING



**VSB**  
(Vintage Sunburst)  
¥84,000 (本体価格 ¥80,000)

## AFJ957

- Expressionist 3pc Mahogany/Maple set-in neck
- Spruce top / Flamed Maple back & sides full-hollow body
- Rosewood fretboard
- 24.7inch Scale
- ART-7 bridge
- Wooden tailpiece
- Ibanez ACH7 (H) neck PU
- Ibanez ACH7 (H) bridge PU
- hardware color : Gold
- string : .011~.065 Flat Wound (D'Addario:ECG24-7)
- color : VSB (Vintage Sunburst)
- depth : 70mm at tail



## NEW MODEL Full Hollow



VYS

(Vintage Yellow Sunburst)

¥78,750 (本体価格 ¥75,000)

## AKJ95

- Expressionist 3pc Mahogany/Maple set-in neck
- Flamed Maple top/back/sides full-hollow body
- Rosewood fretboard
- 24.7inch Scale
- ART-W bridge
- VT06 tailpiece
- Ibanez Super 58 custom (H) neck PU
- Ibanez Super 58 custom (H) bridge PU
- hardware color: Gold
- string: .011~.050 Flat Wound (D'Addario:ECG24)
- color: VYS (Vintage Yellow Sunburst)
- depth: 70mm at tail

## NEW MODEL Full Hollow



VLS

(Violin Sunburst)

¥78,750 (本体価格 ¥75,000)

## AF95

- Expressionist 3pc Mahogany/Maple set-in neck
- Flamed Maple top/back/sides full-hollow body
- Rosewood fretboard
- 24.7inch Scale
- ART-1 bridge
- VT06 tailpiece
- Ibanez Super 58 custom (H) neck PU
- Ibanez Super 58 custom (H) bridge PU
- hardware color: Gold
- string: .010~.052 Round Wound (D'Addario:EXL140)
- color: VLS (Violin Sunburst)
- depth: 70mm at tail

## NEW MODEL Full Hollow



DBS

(Dark Brown Sunburst)

¥78,750 (本体価格 ¥75,000)

## AG95

- Expressionist 3pc Mahogany/Maple set-in neck
- Figured Bubinga top/back/sides full-hollow body
- Rosewood fretboard
- 24.7inch Scale
- ART-1 bridge
- VT06 tailpiece
- Ibanez Super 58 custom (H) neck PU
- Ibanez Super 58 custom (H) bridge PU
- hardware color: Gold
- string: .010~.052 Round Wound (D'Addario:EXL140)
- color: DBS (Dark Brown Sunburst)
- depth: 70mm at tail

## NEW MODEL Semi Hollow



VLS

(Violin Sunburst)

¥78,750 (本体価格 ¥75,000)

## AS93

- Expressionist 3pc Mahogany/Maple set-in neck
- Flamed Maple top/back/sides semi-hollow body
- Rosewood fretboard
- 24.7inch Scale
- ART-1 bridge
- Quik Change III tailpiece
- Ibanez Super 58 custom (H) neck PU
- Ibanez Super 58 custom (H) bridge PU
- hardware color: Gold
- string: .013~.052 Round Wound (D'Addario:EXL140)
- color: VLS (Violin Sunburst)
- depth: 43mm at tail

## Full Hollow



TRD

(Transparent Red)

¥63,000 (本体価格 ¥60,000)

## AFS75T

- Artcore 1pc Mahogany set-in neck
- Maple top/back/sides full-hollow body
- Rosewood fretboard
- 24.7inch Scale
- ART-2 Roller bridge
- VBF70 vibrato tremolo
- Ibanez ACH1 (H) neck PU
- Ibanez ACH2 (H) bridge PU
- hardware color: Chrome
- string: .010~.052 Round Wound (D'Addario:EXL140)
- color: TRD (Transparent Red)
- depth: 43mm at tail

## NEW MODEL SPOT MODEL Semi Hollow



VB

(Vintage Burst)

¥63,000 (本体価格 ¥60,000)

## ASR70

- Artcore 1pc Mahogany set-in neck
- Maple top/back/sides full-hollow body
- Rosewood fretboard
- 24.7inch Scale
- ART-1 bridge
- VT06 tailpiece
- Ibanez DS1 (S) neck PU
- Ibanez DS2 (S) bridge PU
- hardware color: Chrome
- string: .010~.052 Round Wound (D'Addario:EXL140)
- color: VB (Vintage Burst)
- depth: 43mm at tail

## JSM100 Control

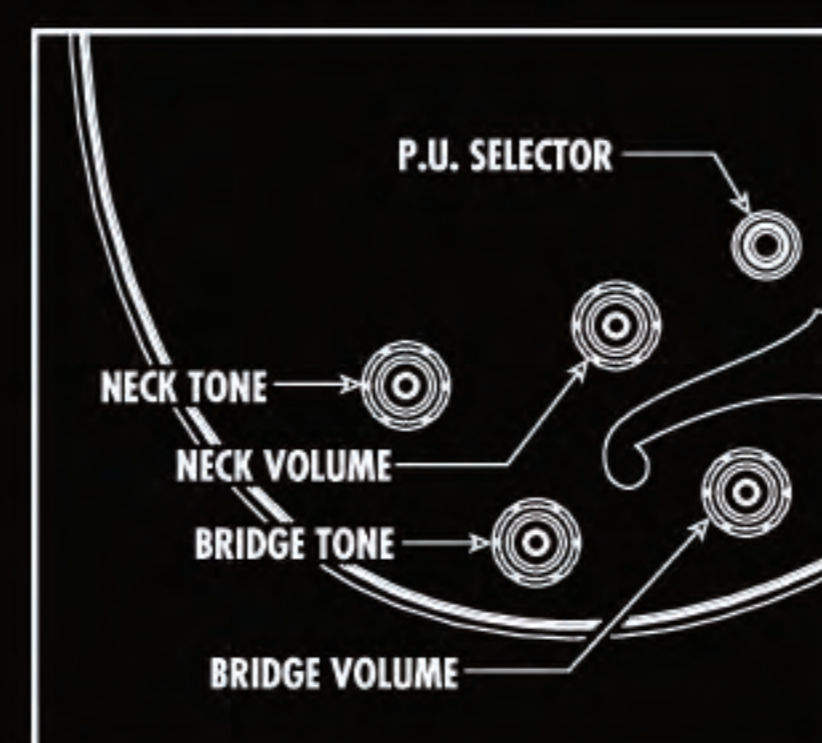

# John Scofield

## SIGNATURE MODEL

## Switching System

H-H (3WAY)

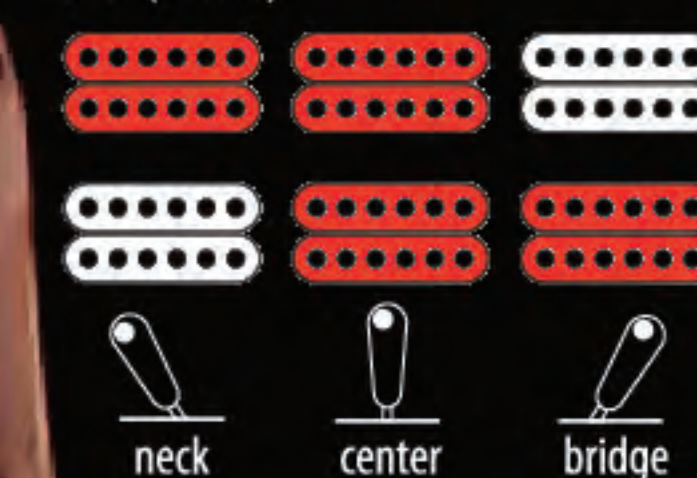

## John Scofield SIGNATURE MODEL Semi Hollow



VT

(Vintage Sunburst)

¥273,000 (本体価格 ¥260,000)

## JSM100

MADE IN JAPAN

- JSM 1pc Mahogany set-in neck
- Flamed Maple top / back / sides body
- Ebony fretboard
- 24.75 inch Scale
- Gotoh® 510BN bridge
- Gotoh® GE101A tailpiece
- Ibanez Super 58 (H) neck PU
- Ibanez Super 58 (H) bridge PU
- hardware color: Gold
- string: .013~.052 Round Wound (D'Addario:PL013/016/022, NW032/042/052)
- color: VT (Vintage Sunburst)
- includes: Hardshell case
- depth: 43mm at tail





# George Benson

## SIGNATURE MODELS

### Switching System

H-H (3WAY)

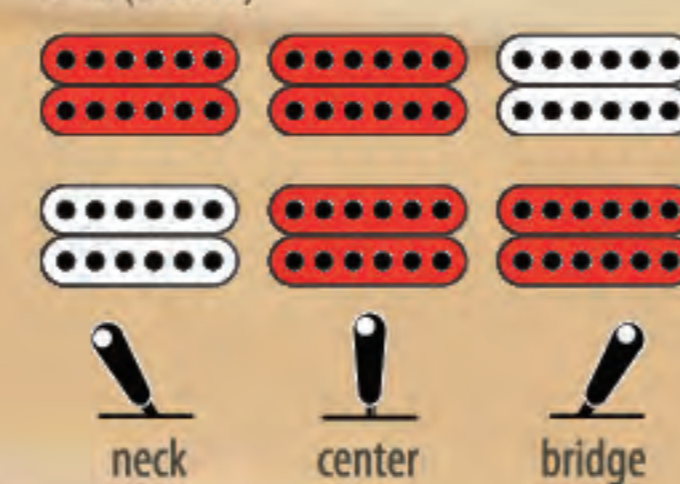

### LGB300 Control

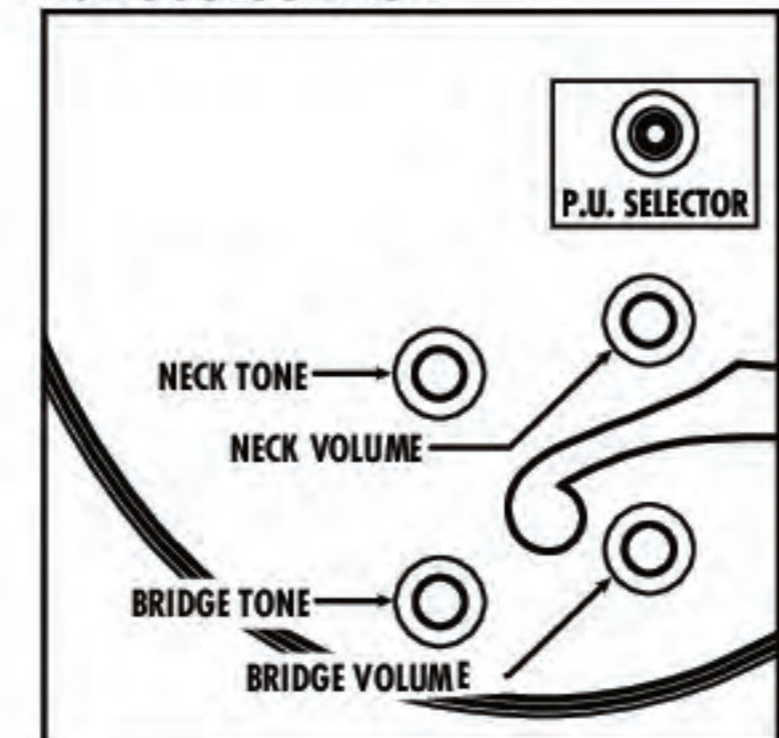

### GB10 Control

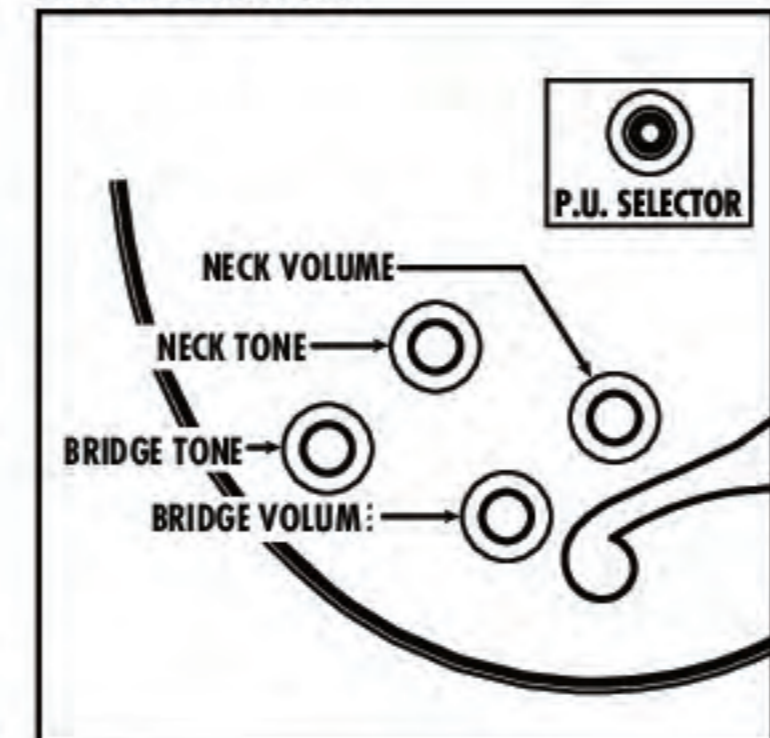

### George Benson SIGNATURE MODEL Full Hollow



**VYS**  
(Vintage Yellow Sunburst)  
¥393,750 (本体価格 ¥375,000)

### LGB300

MADE IN JAPAN

- LGB 3pc Maple set-in neck
- Spruce top / Maple back & sides body
- Ebony fretboard
- 24.7 inch Scale
- Ebony bridge
- LGB300 tailpiece
- Ibanez Super 58 (H) neck PU
- Ibanez Super 58 (H) bridge PU
- hardware color : Gold
- string : .011~.050 Flat Wound (D'Addario:ECG24)
- color : VYS (Vintage Yellow Sunburst)
- includes : Hardshell case
- depth : 80mm at tail

### George Benson SIGNATURE MODEL Full Hollow



**BS**  
(Brown Sunburst)

### GB10

MADE IN JAPAN

- GB 3pc Maple set-in neck
- Spruce top / Maple back & sides body
- Ebony fretboard
- 24.7 inch Scale
- Ebony bridge
- GB10 tailpiece
- Ibanez GB Special (H) neck PU
- Ibanez GB Special (H) bridge PU
- hardware color : Gold
- string : .011~.050 Flat Wound (D'Addario:ECG24)
- color : BS (Brown Sunburst)
- includes : Hardshell case
- depth : 65mm at tail



**NT**  
(Natural)  
¥309,750 (本体価格 ¥295,000)

### Switching System

H-H (3WAY)

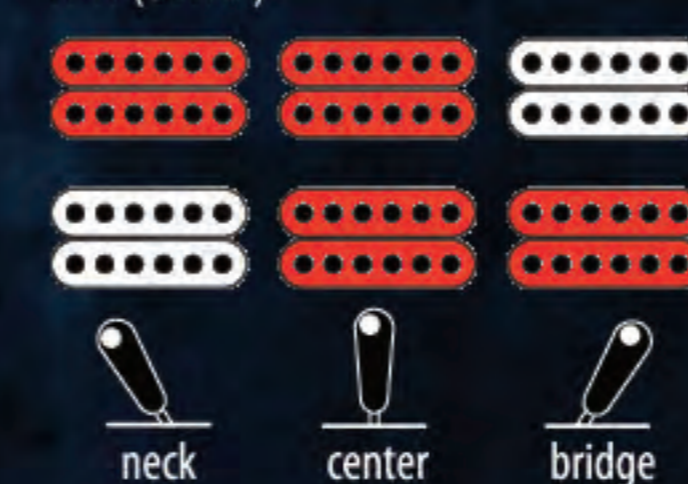

### PM200/PM35 Control

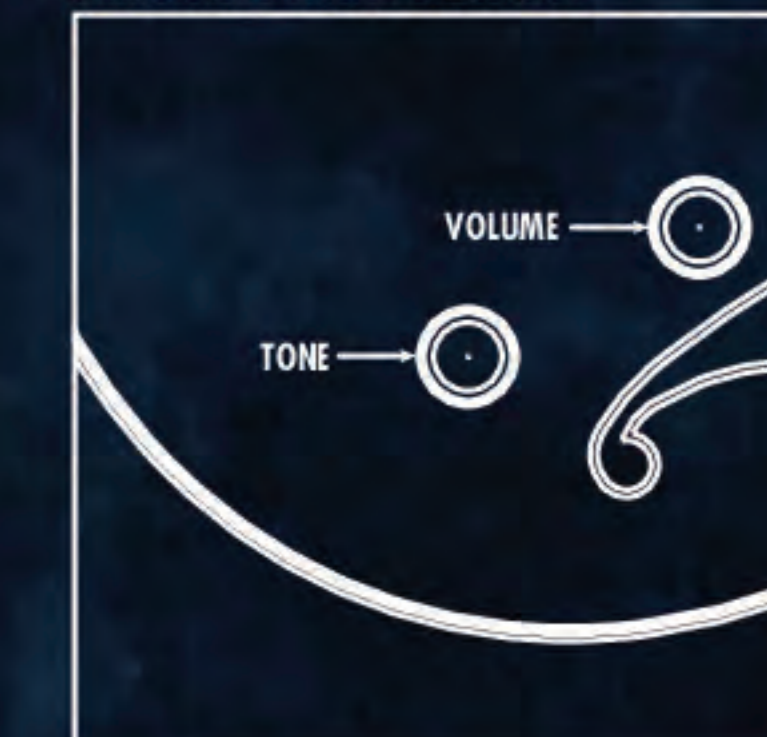

### PM120 Control

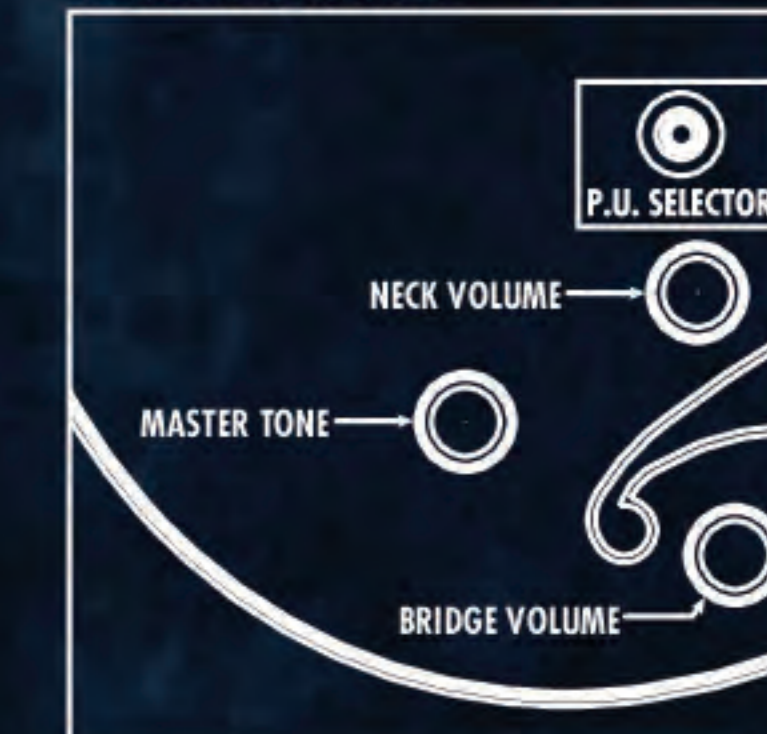

# Pat Metheny

## SIGNATURE MODELS

### NEW MODEL Pat Metheny SIGNATURE MODEL Full Hollow



**NT**  
(Natural)  
¥357,000 (本体価格 ¥340,000)

### PM200

MADE IN JAPAN

- PM 1pc Mahogany set-in neck
- Maple top/back/sides full-hollow body
- Ebony fretboard
- 24.7 inch Scale
- Gotoh® GE103B bridge
- PM tailpiece
- Ibanez Silent 58 (H) neck PU
- hardware color : Gold
- string : .011~.050 Flat Wound (D'Addario:ECG24)
- color : NT (Natural)
- includes : Hardshell case
- depth : 80mm at tail

### Pat Metheny SIGNATURE MODEL Full Hollow



**NT**  
(Natural)  
¥346,500 (本体価格 ¥330,000)

### PM120

MADE IN JAPAN

- PM 1pc Mahogany set-in neck
- Maple top / back / sides full-hollow body
- Ebony fretboard
- 24.7 inch Scale
- Gotoh® GE103B bridge
- PM tailpiece
- Ibanez Silent 58 (H) neck PU
- Ibanez Silent 58 (H) bridge PU
- hardware color : Gold
- string : .011~.050 Flat Wound (D'Addario:ECG24)
- color : NT (Natural)
- includes : Hardshell case
- depth : 50mm at tail

### NEW MODEL Pat Metheny SIGNATURE MODEL Full Hollow



**AA**  
(Antique Amber)  
¥105,000 (本体価格 ¥100,000)

### PM2

- PM 3pc Mahogany/Maple set-in neck
- Maple top/back/sides full-hollow body
- Ebony fretboard
- 24.7inch Scale
- ART-1 bridge
- KT30 tailpiece
- Ibanez Super 58 custom (H) neck PU
- hardware color : Gold
- string : .011~.050 Flat Wound (D'Addario:ECG24)
- color : AA (Antique Amber)
- includes : Hardshell case
- depth : 70mm at tail



# Electric Basses



## TABLE OF CONTENTS

Electric Guitars .....	P.2
<b>Electric Bases</b> .....	P.48
Grooveline .....	P.50
Prestige .....	P.52
PREMIUM .....	P.54
SR .....	P.56
ATK / BTB / Artcore Bass .....	P.60
Signature Model .....	P.62
<b>Acoustic Guitars</b> .....	P.66
<b>Amplifiers / Effects / Accessories</b> ...	P.76





# Grooveline

サウンドはもちろんのことプレイアビリティやバランス、フィット感に至るまで、プレイヤーとしてのこだわりとその追求に妥協をしない。そういうベーシストにこそ弾いて貰いたい、Ibanez Grooveline。



¥283,500 (本体価格 ¥270,000)

## G104

MADE IN JAPAN

- 5pc Grooveline-4 Wenge/Bubinga neck w/ KTS™ TITANIUM rods
- Ash / Alder / Ash body
- Rosewood fretboard
- 34 inch Scale
- Tight-End Bass 4 bridge (19mm string spacing)
- CAP-SAH4 neck PU
- CAP-SAH4 bridge PU
- E4 3-band EQ
- hardware color : Cosmo Black
- string : .045~.105 Round Wound (D'Addario:EXL165)
- color : BBT (Brown Burst)  
NT (Natural)
- includes : Hardshell case

**BBT**  
(Brown Burst)  
**NEW FINISH**

**NT**  
(Natural)

## 5-STRING



¥294,000 (本体価格 ¥280,000)

## G105

MADE IN JAPAN

- 5pc Grooveline-5 Wenge/Bubinga neck w/ KTS™ TITANIUM rods
- Ash / Alder / Ash body
- Rosewood fretboard
- 34 inch Scale
- Tight-End Bass 5 bridge (18mm string spacing)
- CAP-SAH5 neck PU
- CAP-SAH5 bridge PU
- E5 3-band EQ
- hardware color : Cosmo Black
- string : .045~.130 Round Wound (D'Addario:EXL 165 + XLB130)
- color : BBT (Brown Burst)  
NT (Natural)  
TOR (Transparent Orange)
- includes : Hardshell case

**BBT**  
(Brown Burst)  
**NEW FINISH**

**NT**  
(Natural)

**TOR**  
(Transparent Orange)

## NEW MODEL 6-STRING



¥336,000 (本体価格 ¥320,000)

## G106

MADE IN JAPAN

- 5pc Grooveline-6 Wenge/Bubinga neck w/ KTS™ TITANIUM rods
- Ash / Alder / Ash body
- Rosewood fretboard
- 34 inch Scale
- Tight-End Bass 6 bridge (18mm string spacing)
- CAP-SAH6 neck PU
- CAP-SAH6 bridge PU
- E6 3-band EQ
- hardware color : Cosmo Black
- string : .032~.130 Round Wound (D'Addario:EXL165 + XLB032/130)
- color : NT (Natural)
- includes : Hardshell case

**受注生産品**  
**NT**  
(Natural)





# Prestige Precision, Performance, Playability

## EVERYTHING YOU'VE EVER DREAMED OF IN A GUITAR OR BASS

緻密に作り上げられ、高性能・高機能であり、さらには優れたプレイアビリティを備えていること。実践機に必要なそれら要素を全て備え、Made in Japanで完成される、Ibanez Prestige。

# SR Prestige

Ibanezベースの代名詞 "Soundgear (サウンド・ギア)" —SR。ベアシストの「弾きやすく、使いやすい」、つまりプレイアビリティの追求が25年にわたり不変のプロダクト・コンセプト。オリジナル・アクティブ・サーキットとのコンビネーションでサウンドには多彩さを求め、あらゆるジャンルに対応可能だ。

### LIMITED MODEL 5-STRING



**RB**  
(Ruby)  
¥367,500 (本体価格 ¥350,000)

### SR5JCTLT

MADE IN JAPAN

- 5pc Atlas-5 HP Wenge/Bubinga neck w/ KTS™ TITANIUM rods
- Japanese Horse Chestnut / Mahogany / Japanese Horse Chestnut body
- Wenge fretboard
- 34 inch Scale
- MR-4 bridge (16.5mm string spacing)
- Bartolini™ Custom neck PU
- Bartolini™ Custom bridge PU
- PWC III 3-band EQ
- hardware color : Gold
- string : .045/.065/.085/.105/.130 (Elixir)
- color : RB (Ruby)
- includes : Hardshell case

### SR5000E

MADE IN JAPAN

- 5pc Atlas-4 HP Wenge/Bubinga neck w/ KTS™ TITANIUM rods
- Wenge / Mahogany / Wenge body
- Wenge fretboard
- 34 inch Scale
- MR-4 bridge (19mm string spacing)
- Bartolini™ Custom neck PU
- Bartolini™ Custom bridge PU
- PWC III 3-band EQ
- hardware color : Gold
- string : .045/.065/.085/.105 (Elixir)
- color : OL (Oil)
- includes : Hardshell case

### SR5005E

MADE IN JAPAN

- 5pc Atlas-5 HP Wenge/Bubinga neck w/ KTS™ TITANIUM rods
- Wenge / Mahogany / Wenge body
- Wenge fretboard
- 34 inch Scale
- MR-4 bridge (16.5mm string spacing)
- Bartolini™ Custom neck PU
- Bartolini™ Custom bridge PU
- PWC III 3-band EQ
- hardware color : Gold
- string : .045/.065/.085/.105/.130 (Elixir)
- color : OL (Oil)
- includes : Hardshell case

### SR5006E

MADE IN JAPAN

- 5pc Atlas-6 HP Wenge/Bubinga neck w/ KTS™ TITANIUM rods
- Wenge / Mahogany / Wenge body
- Wenge fretboard
- 34 inch Scale
- MR-4 bridge (16.5mm string spacing)
- Bartolini™ Custom neck PU
- Bartolini™ Custom bridge PU
- PWC III 3-band EQ
- hardware color : Gold
- string : .032/.045/.065/.085/.105/.130 (Elixir)
- color : OL (Oil)
- includes : Hardshell case

### 5-STRING



**OL**  
(Oil)  
¥294,000 (本体価格 ¥280,000)

### 6-STRING



**OL**  
(Oil)  
¥304,500 (本体価格 ¥290,000)

### NEW MODEL SPOT MODEL



**BK**  
(Black)  
**CW**  
(Crimson Wine)  
¥168,000 (本体価格 ¥160,000)

### SR2500

MADE IN JAPAN

- 3pc SR4-custom Maple neck
- Alder body
- Rosewood fretboard
- 34 inch Scale
- MR-4 bridge (19mm string spacing)
- CAP-SA44 neck PU
- CAP-SA44 bridge PU
- BEQIII 3band-EQ w/3way mid freq. selector
- hardware color : Cosmo Black
- string : .045~.105 Round Wound (D'Addario:EXL165)
- color : BK (Black)  
CW (Crimson Wine)
- includes : Hardshell case

### NEW MODEL SPOT MODEL 5-STRING



**BK**  
(Black)  
¥178,500 (本体価格 ¥170,000)

### SR2505

MADE IN JAPAN

- 3pc SR5-custom Maple neck
- Alder body
- Rosewood fretboard
- 34 inch Scale
- MR-4 bridge (16.5mm string spacing)
- CAP-SA45 neck PU
- CAP-SA45 bridge PU
- BEQIII 3band-EQ w/3way mid freq. selector
- hardware color : Cosmo Black
- string : .045~.130 Round Wound (D'Addario:EXL165 + XLB130)
- color : BK (Black)
- includes : Hardshell case

# ATK Prestige

大型のメタル・プレート・ブリッジとオリジナル・デザインのピックガードが唯一無二の存在感を放つ "Attack(アタック)" —ATK。アッシュ・ボディが生み出す申し分のない音域バランスとサステイン。しっかりと握り心地のメイプル・ネックが実現するレンジの広さ、そしてCAP-Double Humbuckerのパンチの効いたサウンドが特徴だ。



**NT**  
(Natural)  
¥194,250 (本体価格 ¥185,000)

### ATK1200

MADE IN JAPAN

- 3pc ATK4 HP Maple neck
- Ash body
- Maple fretboard
- 34 inch Scale
- ATK4 bridge (19mm string spacing)
- CAP-SA44 neck PU
- CAP-DH bridge PU
- ATK N3 3-band EQ
- hardware color : Chrome
- string : .045~.105 Round Wound (D'Addario:EXL165)
- color : NT (Natural)
- includes : Hardshell case

### NEW MODEL SPOT MODEL 5-STRING



**NT**  
(Natural)  
¥204,750 (本体価格 ¥195,000)

### ATK1205

MADE IN JAPAN

- 3pc ATK5 HP Maple neck
- Ash body
- Maple fretboard
- 34 inch Scale
- ATK5 bridge (18mm string spacing)
- CAP-SA45 neck PU
- CAP-DH5 bridge PU
- ATK N3 3-band EQ
- hardware color : Chrome
- string : .045~.130 Round Wound (D'Addario:EXL165 + XLB130)
- color : NT (Natural)
- includes : Hardshell case





## PREMIUM

### PERFORMANCE BEYOND EXPECTATION

プレイヤービリティ、ハードウェアの性能とオリジナリティ。

それらはIbanezのギターとベースが追求するハイ・パフォーマンスには欠かせない要素である。

カスタム・モデルや高級品ならいざ知らず、

それらを選ばなくとも信頼性とパフォーマンスの高い製品をもっと多くの

ギタリストやベーシストに届けることができないだろうか？

これらを命題に、既存のイメージを覆すほどの可能性を秘めた

"期待以上のハイ・パフォーマンス・ギア"、Ibanez "Premium"。

## SR PREMIUM



VNF  
(Vintage Natural Flat)  
¥141,750 (本体価格 ¥135,000)

### SR1200

- 5pc Atlas-4 HP Wenge/Bubinga neck w/ KTS™ TITANIUM rods
- Ovangkol top / Mahogany body
- Rosewood fretboard
- 34 inch Scale
- MR-4 bridge (19mm string spacing)
- Nordstrand™ BigSingle 4 neck PU
- Nordstrand™ BigSingle 4 bridge PU
- EQB-IIISC 3-band EQ
- hardware color: Gold
- string: .045/.065/.085/.105 (Elixir)
- color: VNF (Vintage Natural Flat)
- includes: Gigcase

### 5-STRING



VNF  
(Vintage Natural Flat)  
¥152,250 (本体価格 ¥145,000)

### SR1205

- 5pc Atlas-5 HP Wenge/Bubinga neck w/ KTS™ TITANIUM rods
- Ovangkol top / Mahogany body
- Rosewood fretboard
- 34 inch Scale
- MR-4 bridge (16.5mm string spacing)
- Nordstrand™ BigSingle 5 neck PU
- Nordstrand™ BigSingle 5 bridge PU
- EQB-IIISC 3-band EQ
- hardware color: Gold
- string: .045/.065/.085/.105/.130 (Elixir)
- color: VNF (Vintage Natural Flat)
- includes: Gigcase

### SPOT MODEL 6-STRING



VNF  
(Vintage Natural Flat)  
¥162,750 (本体価格 ¥155,000)

### SR1206

- 5pc Atlas-6 HP Wenge/Bubinga neck w/ KTS™ TITANIUM rods
- Ovangkol top / Mahogany body
- Rosewood fretboard
- 34 inch Scale
- MR-4 bridge (16.5mm string spacing)
- Nordstrand™ BigSingle 6 neck PU
- Nordstrand™ BigSingle 6 bridge PU
- EQB-IIISC 3-band EQ
- hardware color: Gold
- string: .032/.045/.065/.085/.105/.130 (Elixir)
- color: VNF (Vintage Natural Flat)
- includes: Gigcase

## ATK PREMIUM

### NEW MODEL



WNF  
(Walnut Flat)  
¥89,250 (本体価格 ¥85,000)

### ATK800

- 3pc ATK4 Maple neck
- Ash body
- Maple fretboard
- 34inch Scale
- ATK4 bridge (19mm string spacing)
- CAP-SAH4 neck PU
- CAP-DH bridge PU
- ATK N3 3-band EQ
- hardware color: Chrome
- string: .045~.105 Round Wound (D'Addario:EXL165)
- color: WNF (Walnut Flat)
- includes: Gigcase

### NEW MODEL SPOT MODEL 5-STRING



WNF  
(Walnut Flat)  
¥99,750 (本体価格 ¥95,000)

### ATK805

- 3pc ATK5 Maple neck
- Ash body
- Maple fretboard
- 34inch Scale
- ATK5 bridge (18mm string spacing)
- CAP-SAH5 neck PU
- CAP-DH5 bridge PU
- ATK N3 3-band EQ
- hardware color: Chrome
- string: .045~.130 Round Wound (D'Addario:EXL165 + XLB130)
- color: WNF (Walnut Flat)
- includes: Gigcase

## BTB PREMIUM

### NEW MODEL 5-STRING



VNF  
(Vintage Natural Flat)  
¥178,500 (本体価格 ¥170,000)

### BTB1405

- 7pc BTB5 Maple/Bubinga/Walnut neck-thru
- Flamed Maple top / Mahogany back wing body
- Rosewood fretboard
- 35inch Scale
- Mono-rail 4 bridge (19mm string spacing)
- Nordstrand™ BigSingle 5 neck PU
- Nordstrand™ BigSingle 5 bridge PU
- EQB-IIISC 3-band EQ
- hardware color: Gold
- string: .045/.065/.085/.105/.130 (Elixir)
- color: VNF (Vintage Natural Flat)
- includes: Gigcase

### NEW MODEL 6-STRING



VNF  
(Vintage Natural Flat)  
¥189,000 (本体価格 ¥180,000)

### BTB1406

- 7pc BTB6 Maple/Bubinga/Walnut neck-thru
- Flamed Maple top / Mahogany back wing body
- Rosewood fretboard
- 35inch Scale
- Mono-rail 4 bridge (17mm string spacing)
- Nordstrand™ BigSingle 6 neck PU
- Nordstrand™ BigSingle 6 bridge PU
- EQB-IIISC 3-band EQ
- hardware color: Gold
- string: .032/.045/.065/.085/.105/.130 (Elixir)
- color: VNF (Vintage Natural Flat)
- includes: Gigcase





## NEW MODEL



¥110,250 (本体価格 ¥105,000)

## SR800

- 5pc SR4 Jatoba/Bubinga neck
- Poplar Burl top/Mahogany body
- Rosewood fretboard
- 34inch Scale
- Accu-Cast B300 bridge (19mm string spacing)
- Bartolini® MK1 neck PU
- Bartolini® MK1 bridge PU
- EQB-IIIS 3-band EQ
- hardware color: Gold
- string: .045/.065/.085/.105 (Elixir)
- color: AM (Amber)

AM  
(Amber)

## 5-STRING



¥120,750 (本体価格 ¥115,000)

## SR805

- 5pc SR5 Jatoba/Bubinga neck
- Poplar Burl top/Mahogany body
- Rosewood fretboard
- 34inch Scale
- Accu-Cast B305 bridge (16.5mm string spacing)
- Bartolini® MK1 neck PU
- Bartolini® MK1 bridge PU
- EQB-IIIS 3-band EQ
- hardware color: Gold
- string: .045/.065/.085/.105/.130 (Elixir)
- color: AM (Amber)

AM  
(Amber)



BM  
(Brown Mahogany)

## SR500

- 5pc SR4 Jatoba/Bubinga neck
- Mahogany body
- Rosewood fretboard
- 34 inch Scale
- Accu-Cast B300 bridge (19mm string spacing)
- Bartolini® MK1 neck PU
- Bartolini® MK1 bridge PU
- EQB-IIIS 3-band EQ
- hardware color: Cosmo Black
- string: .045/.065/.085/.105 (Elixir)
- color: BM (Brown Mahogany)
- TKF (Transparent Black Flat)

TKF  
(Transparent Black Flat)



¥89,250 (本体価格 ¥85,000)

## 5-STRING



BM  
(Brown Mahogany)



TKF  
(Transparent Black Flat)

¥99,750 (本体価格 ¥95,000)

## SR505

- 5pc SR5 Jatoba/Bubinga neck
- Mahogany body
- Rosewood fretboard
- 34 inch Scale
- Accu-Cast B305 bridge (16.5mm string spacing)
- Bartolini® MK1 neck PU
- Bartolini® MK1 bridge PU
- EQB-IIIS 3-band EQ
- hardware color: Cosmo Black
- string: .045/.065/.085/.105/.130 (Elixir)
- color: BM (Brown Mahogany)
- TKF (Transparent Black Flat)

## 6-STRING



BM  
(Brown Mahogany)

¥110,250 (本体価格 ¥105,000)

## SR506

- 5pc SR6 Jatoba/Bubinga neck
- Mahogany body
- Rosewood fretboard
- 34 inch Scale
- Accu-Cast B306 bridge (16.5mm string spacing)
- Bartolini® MK1 neck PU
- Bartolini® MK1 bridge PU
- EQB-IIIS 3-band EQ
- hardware color: Cosmo Black
- string: .032/.045/.065/.085/.105/.130 (Elixir)
- color: BM (Brown Mahogany)

## NEW MODEL



TK  
(Transparent Black)



TR  
(Transparent Red)

¥78,750 (本体価格 ¥75,000)

## SR450QM

- 5pc SR4 Maple/Rosewood neck
- Quilted Maple top / Alder body
- Rosewood fretboard
- 34 inch Scale
- Accu-Cast B300 bridge (19mm string spacing)
- Duncan / Ibanez J neck PU
- Duncan / Ibanez J bridge PU
- EQB-IIIS 3-band EQ
- hardware color: Cosmo Black
- string: .045-.105 Round Wound (D'Addario:EXL165)
- color: TK (Transparent Black)
- TR (Transparent Red)

## NEW MODEL



TFB  
(Tri Fade Burst)

¥73,500 (本体価格 ¥70,000)

## SR420

- 5pc SR4 Maple/Rosewood neck
- Alder body
- Rosewood fretboard
- 34 inch Scale
- Accu-Cast B300 bridge (19mm string spacing)
- Duncan / Ibanez J neck PU
- Duncan / Ibanez J bridge PU
- EQB-IIIS 3-band EQ
- hardware color: Cosmo Black
- string: .045-.105 Round Wound (D'Addario:EXL165)
- color: TFB (Tri Fade Burst)





**CNB**  
(Charcoal Brown Burst)



**TGB**  
(Transparent Gray Burst)



**TLB**  
(Transparent Lavender Burst)



**TRB**  
(Transparent Red Burst)  
¥68,250 (本体価格 ¥65,000)

### SR400FM

- 5pc SR4 Maple/Rosewood neck
- Flamed Maple top / Mahogany body
- Rosewood fretboard
- 34 inch Scale
- Accu-Cast B300 bridge (19mm string spacing)
- CAP EXF-N2 neck PU
- CAP EXF-N2 bridge PU
- EQB-IIID 3-band EQ
- hardware color : Cosmo Black
- string : .045~.105 Round Wound (D'Addario:EXL165)
- color : CNB (Charcoal Brown Burst)  
TGB (Transparent Gray Burst)  
TLB (Transparent Lavender Burst)  
TRB (Transparent Red Burst)



**CNB**  
(Charcoal Brown Burst)



**TGB**  
(Transparent Gray Burst)



**TRB**  
(Transparent Red Burst)  
¥78,750 (本体価格 ¥75,000)

### SR405FM

- 5pc SR5 Maple/Rosewood neck
- Flamed Maple top / Mahogany body
- Rosewood fretboard
- 34 inch Scale
- Accu-Cast B305 bridge (16.5mm string spacing)
- CAP EXF-N2 neck PU
- CAP EXF-N2 bridge PU
- EQB-IIID 3-band EQ
- hardware color : Cosmo Black
- string : .045~.130 Round Wound (D'Addario:EXL165 + XLB130)
- color : CNB (Charcoal Brown Burst)  
TGB (Transparent Gray Burst)  
TRB (Transparent Red Burst)



**CA**  
(Candy Apple)



**IPT**  
(Iron Pewter)



**PW**  
(Pearl White)  
¥52,500 (本体価格 ¥50,000)

### SR300

- 5pc SR4 Maple/Rosewood neck
- Agathis body
- Rosewood fretboard
- 34 inch Scale
- Accu-Cast B120 bridge (19mm string spacing)
- CAP EXF-N2 neck PU
- CAP EXF-N2 bridge PU
- EQB-IIID 3-band EQ
- hardware color : Cosmo Black
- string : .045~.105 Round Wound (D'Addario:EXL165)
- color : CA (Candy Apple)  
IPT (Iron Pewter)  
PW (Pearl White)

### SPOT MODEL Left-handed



**IPT**  
(Iron Pewter)  
¥63,000 (本体価格 ¥60,000)

### SR300L

- 5pc SR4 Maple/Rosewood neck
- Agathis body
- Rosewood fretboard
- 34 inch Scale
- Accu-Cast B120 bridge (19mm string spacing)
- CAP EXF-N2 neck PU
- CAP EXF-N2 bridge PU
- EQB-IIID 3-band EQ
- hardware color : Cosmo Black
- string : .045~.105 Round Wound (D'Addario:EXL165)
- color : IPT (Iron Pewter)



**IPT**  
(Iron Pewter)



**PW**  
(Pearl White)  
¥63,000 (本体価格 ¥60,000)

### SR305

- 5pc SR5 Maple/Rosewood neck
- Agathis body
- Rosewood fretboard
- 34 inch Scale
- Accu-Cast B125 bridge (16.5mm string spacing)
- CAP EXF-N2 neck PU
- CAP EXF-N2 bridge PU
- EQB-IIID 3-band EQ
- hardware color : Cosmo Black
- string : .045~.130 Round Wound (D'Addario:EXL165 + XLB130)
- color : IPT (Iron Pewter)  
PW (Pearl White)



## ATK



NT  
(Natural)  
¥60,900 (本体価格 ¥58,000)

## ATK200

- 3pc ATK4 Maple neck
- Ash body
- Rosewood fretboard
- 34 inch Scale
- ATK4 bridge (19mm string spacing)
- CAP-DH bridge PU
- ATK N2 3-band EQ
- hardware color: Chrome
- string: .045~.105 Round Wound (D'Addario:EXL165)
- color: BK (Black)  
NT (Natural)

## 5-STRING



NT  
(Natural)  
¥66,150 (本体価格 ¥63,000)

## ATK205

- 3pc ATK5 Maple neck
- Ash body
- Maple fretboard
- 34inch Scale
- ATK5 bridge (18mm string spacing)
- CAP-DHS bridge PU
- ATK N2 3-band EQ
- hardware color: Chrome
- string: .045~.130 Round Wound (D'Addario:EXL165 + XLB130)
- color: NT (Natural)

## BTB

35インチ・エクストラ・ロング・スケールのスルーネック構造に、他弦の振動の影響をうけにくく各弦毎に独立した構造のモノレール・ブリッジを搭載。専用に設計されたBartolini® BH1ピックアップと3バンドEQを搭載し、ハイスペックと共に自由な表現力を備えたベース、それがIbanez BTB—Boutique Bass。

## 5-STRING



NTF  
(Natural Flat)  
¥110,250 (本体価格 ¥105,000)

## BTB675

- 5pc BTB5 Maple/Bubinga neck-thru
- Walnut top / Ash wing body
- Rosewood fretboard
- 35 inch Scale
- MR-2 bridge (19mm string spacing)
- Bartolini® BH1-N neck PU
- Bartolini® BH1-B bridge PU
- EQB-III S 3-band EQ
- hardware color: Cosmo Black
- string: .045/.065/.085/.105/.130 (Elixir)
- color: NTF (Natural Flat)

## 6-STRING



NTF  
(Natural Flat)  
¥120,750 (本体価格 ¥115,000)

## BTB676

- 5pc BTB6 Maple/Bubinga neck-thru
- Walnut top / Ash wing body
- Rosewood fretboard
- 35 inch Scale
- MR-2 bridge (17mm string spacing)
- Bartolini® BH1-N neck PU
- Bartolini® BH1-B bridge PU
- EQB-III S 3-band EQ
- hardware color: Cosmo Black
- string: .032/.045/.065/.085/.105/.130 (Elixir)
- color: NTF (Natural Flat)

## 5-STRING



AM  
(Amber)  
¥126,000 (本体価格 ¥120,000)

## BTB775PB

- 5pc BTB5 Maple/Bubinga neck-thru
- Poplar Burl top / Mahogany wing body
- Rosewood fretboard
- 35 inch Scale
- MR-2 bridge (19mm string spacing)
- Bartolini® BH1-N neck PU
- Bartolini® BH1-B bridge PU
- EQB-III S 3-band EQ
- hardware color: Cosmo Black
- string: .045/.065/.085/.105/.130 (Elixir)
- color: AM (Amber)

## 6-STRING



AM  
(Amber)  
¥136,500 (本体価格 ¥130,000)

## BTB776PB

- 5pc BTB6 Maple/Bubinga neck-thru
- Poplar Burl top / Mahogany wing body
- Rosewood fretboard
- 35 inch Scale
- MR-2 bridge (17mm string spacing)
- Bartolini® BH1-N neck PU
- Bartolini® BH1-B bridge PU
- EQB-III S 3-band EQ
- hardware color: Cosmo Black
- string: .032/.045/.065/.085/.105/.130 (Elixir)
- color: AM (Amber)

## ARTCORE BASS

クラシカルなベース・サウンドを求めるプレイヤーに最適なARTCORE BASS。セミ・ホロウボディの“AGB” / “ASB”、フル・ホロウボディの“AFB”。いずれも30インチ・ショート・スケールのセットイン・ネックを採用、5弦モデルもラインナップ。

## NEW MODEL



SRD  
(Sunset Red)  
¥78,750 (本体価格 ¥75,000)

## AFB200

- Artcore 3pc Mahogany/Maple set-in neck
- Maple top/back/sides full-hollow body
- Rosewood fretboard
- 30.3inch Scale
- Rosewood bridge (19mm string spacing)
- FBT40 tailpiece
- Ibanez ACHB-2 neck PU
- Ibanez ACHB-2 bridge PU
- hardware color: Gold
- string: .050~.105 Round Wound (D'Addario:EXL160M)
- color: SRD (Sunset Red)



TBR  
(Transparent Brown)  
¥73,500 (本体価格 ¥70,000)

## AGB200

- 3pc Artcore Bass Mahogany/Maple set-in neck
- Maple top / back / sides semi-hollow body
- Rosewood fretboard
- 30.3 inch Scale
- Gibraltar III bass bridge (19mm string spacing)
- Quik Change III bass tailpiece
- Ibanez ACHB-2 neck PU
- Ibanez ACHB-2 bridge PU
- hardware color: Gold
- string: .050~.105 Round Wound (D'Addario:EXL160M)
- color: TBR (Transparent Brown)

## NEW MODEL 5-STRING



DVS  
(Dark Violin Sunburst)  
¥84,000 (本体価格 ¥80,000)

## AGB205

- Artcore 3pc Mahogany/Maple set-in neck
- Maple top/back/sides semi-hollow body
- Rosewood fretboard
- 30.3inch Scale
- Artcore Custom 5 bridge (15mm string spacing)
- Artcore Custom 5 tailpiece
- Ibanez ACHB-2 neck PU
- Ibanez ACHB-2 bridge PU
- hardware color: Gold
- string: .055~.145 Round Wound (D'Addario:EXL230 + XLB145)
- color: DVS (Dark Violin Sunburst)

## NEW MODEL



BS  
(Brown Sunburst)  
¥73,500 (本体価格 ¥70,000)

## ASB180

- Artcore 3pc Mahogany/Maple set-in neck
- Maple top/back/sides semi-hollow body
- Rosewood fretboard
- 30.3inch Scale
- Gibraltar III bass bridge (19mm string spacing)
- Quik Change III bass tailpiece
- Ibanez ACHB-3 neck PU
- Ibanez ACHB-2 bridge PU
- hardware color: Chrome
- string: .050~.105 Round Wound (D'Addario:EXL160M)
- color: BS (Brown Sunburst)





## Peter Iwers SIGNATURE MODEL 5-STRING



**PW**  
(Pearl White)  
¥194,250 (本体価格 ¥185,000)

## PIB2

- 5pc PIB Maple/Bubinga neck
- Maple body
- Rosewood fretboard
- 34 inch Scale
- MR-4 bridge (16.5mm string spacing)
- Bartolini® Custom neck PU
- Bartolini® Custom bridge PU
- 1 Volume Control w/ PIB Active Circuit
- hardware color: Gold
- string: .045~.120 Round Wound (D'Addario:EXL165 + XLB120)
- color: PW (Pearl White)
- includes: Hardshell case
- factory tuning: 1D#, 2A#, 3F, 4C, 5A#



## Fieldy SIGNATURE MODEL 5-STRING



**BKF**  
(Black Flat)  
¥168,000 (本体価格 ¥160,000)

## K5

- 5pc K5 Maple/Bubinga neck
- Mahogany body
- Rosewood fretboard
- 34 inch Scale
- Die-Cast EB-7 bridge (15.8 mm string spacing)
- Ibanez ADX5N neck PU
- Ibanez ADX5B bridge PU
- Vari-mid III 3-band EQ
- hardware color: Black
- string: .045/.065/.085/.105/.130 (Elixir)
- color: BKF (Black Flat)
- includes: Hardshell case

Vari-mid III 3-band EQ



EQB-IIDX 2-band EQ

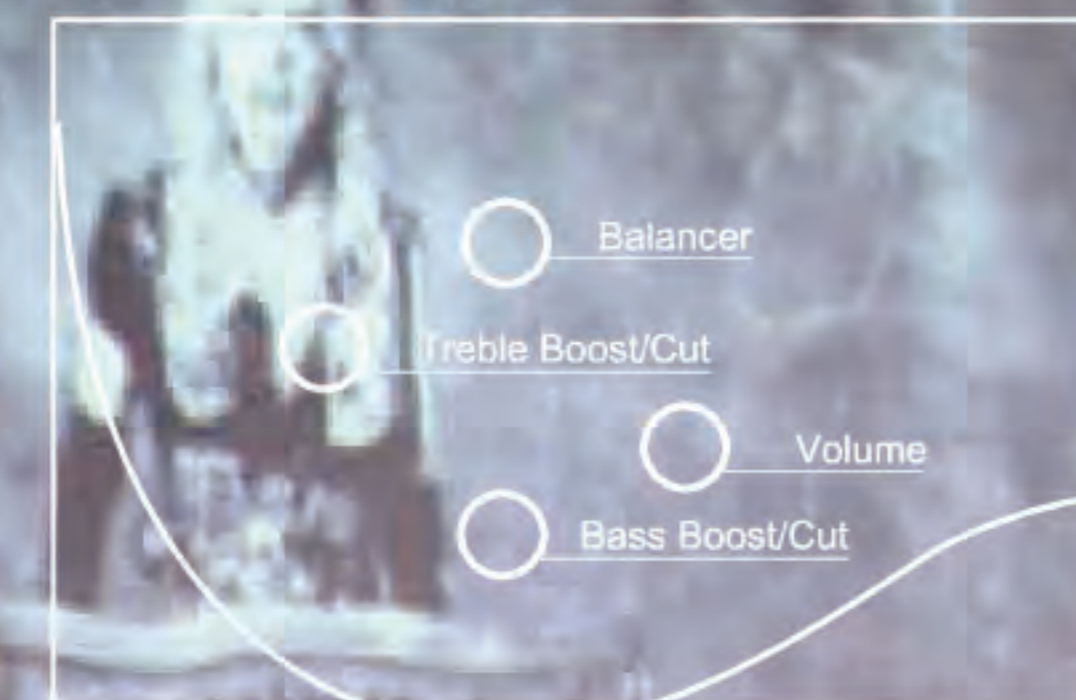

## Sharlee D'Angelo SIGNATURE MODEL



**PW**  
(Pearl White)  
¥126,000 (本体価格 ¥120,000)

## SDB3

- 5pc SDB Maple/Bubinga neck-thru
- Mahogany wing body
- Rosewood fretboard
- 34 inch Scale
- MR-4 bridge (19mm string spacing)
- PFR-N4 neck PU
- PFR-B4 bridge PU
- EQB-IIDX 2-band EQ
- hardware color: Cosmo Black
- string: .060~.120 Round Wound (D'Addario:XLB060/080/100/120)
- color: WHF (White Flat)
- includes: Hardshell case
- factory tuning: 1D#, 2A#, 3F, 4C



## Mike D'Antonio SIGNATURE MODEL



**BK**  
(Black)  
¥157,500 (本体価格 ¥150,000)

## MDB3

- 3pc MDB Maple neck
- Mahogany body
- Rosewood fretboard
- 34 inch Scale
- Accu-cast B200 bridge (19mm string spacing)
- Seymour Duncan® SPB-3 PU
- hardware color: Cosmo Black
- string: .055~.120 Round Wound (D'Addario:XLB055/075/095/120)
- color: BK (Black)
- includes: Hardshell case
- factory tuning: 1F, 2C, 3G, 4C





# Gerald Veasley

## SIGNATURE MODEL

Aguilar® OBP-3 3-band EQ



### Gerald Veasley SIGNATURE MODEL 6-STRING

GVB1006

MADE IN JAPAN



AM  
(Amber)  
受注生産品  
¥787,500 (本体価格 ¥750,000)

- 3pc GVB Maple/Wenge neck
- Figured Maple top / Alder body
- Rosewood fretboard
- 34 inch Scale
- MR-4 bridge (14mm string spacing)
- Bartolini® P45C-B neck PU
- Bartolini® P45C-T bridge PU
- Aguilar® OBP-3 3-band EQ
- hardware color : Cosmo Black
- string : .030/.040/.060/.080/.100/.120 (Jim Dunlop)
- color : AM (Amber)
- includes : Hardshell case
- factory tuning : 1C, 2G, 3D, 4A, 5E, 6B

# Gary Willis

## SIGNATURE MODEL

### Gary Willis SIGNATURE MODEL 5-STRING

GWB1005

MADE IN JAPAN



NTF  
(Natural Flat)  
受注生産品  
¥472,500 (本体価格 ¥450,000)

- 3pc GWB Maple neck
- Swamp Ash body
- Rosewood fretboard
- 34 inch Scale
- STD-5 bridge (16.5mm string spacing)
- Bartolini® GWB bridge PU
- Bartolini® NTBT 2-band EQ
- hardware color : Black
- string : .045~.130 Coated (D'Addario:EXP165 + EXPXLB130)
- color : NTF (Natural Flat)
- includes : Hardshell case

Bartolini® NTBT 2-band EQ

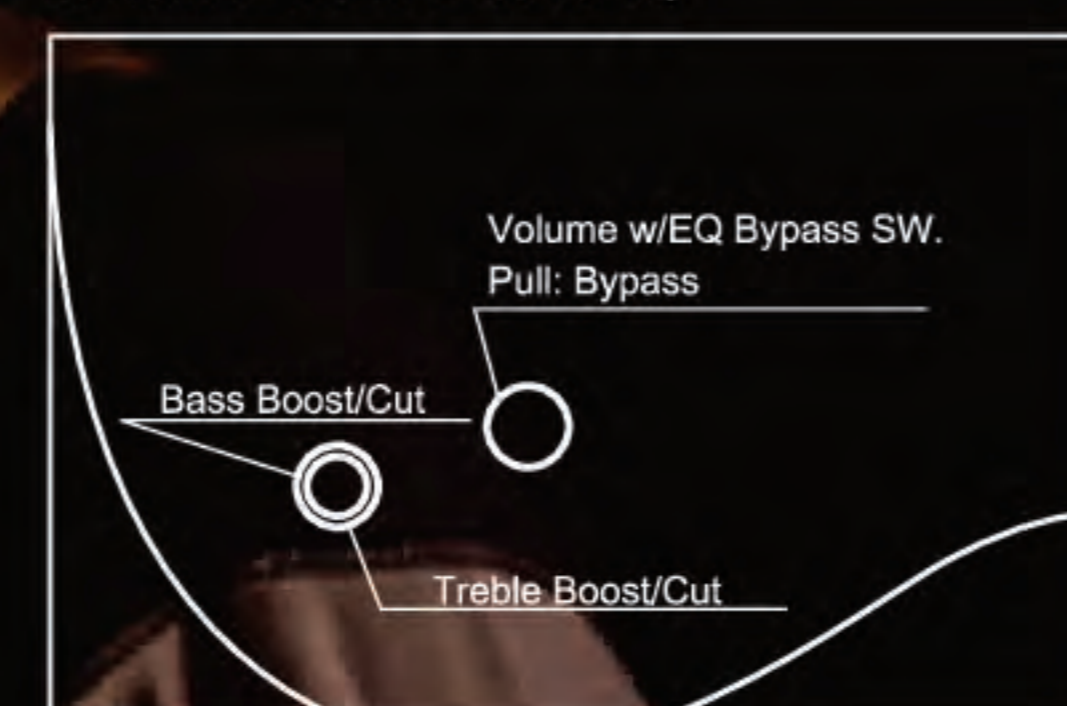

## Bass EQ

E4 / E5 / E6 3-band EQ

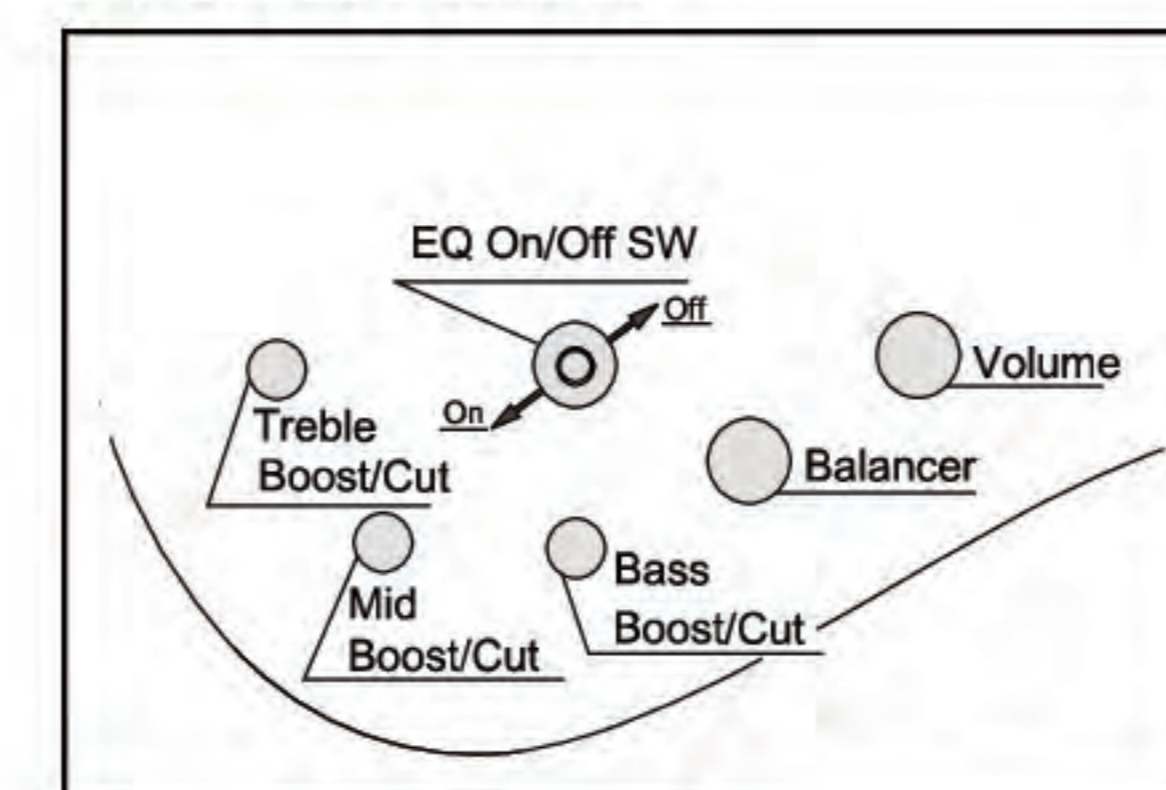

PWC III 3-band EQ

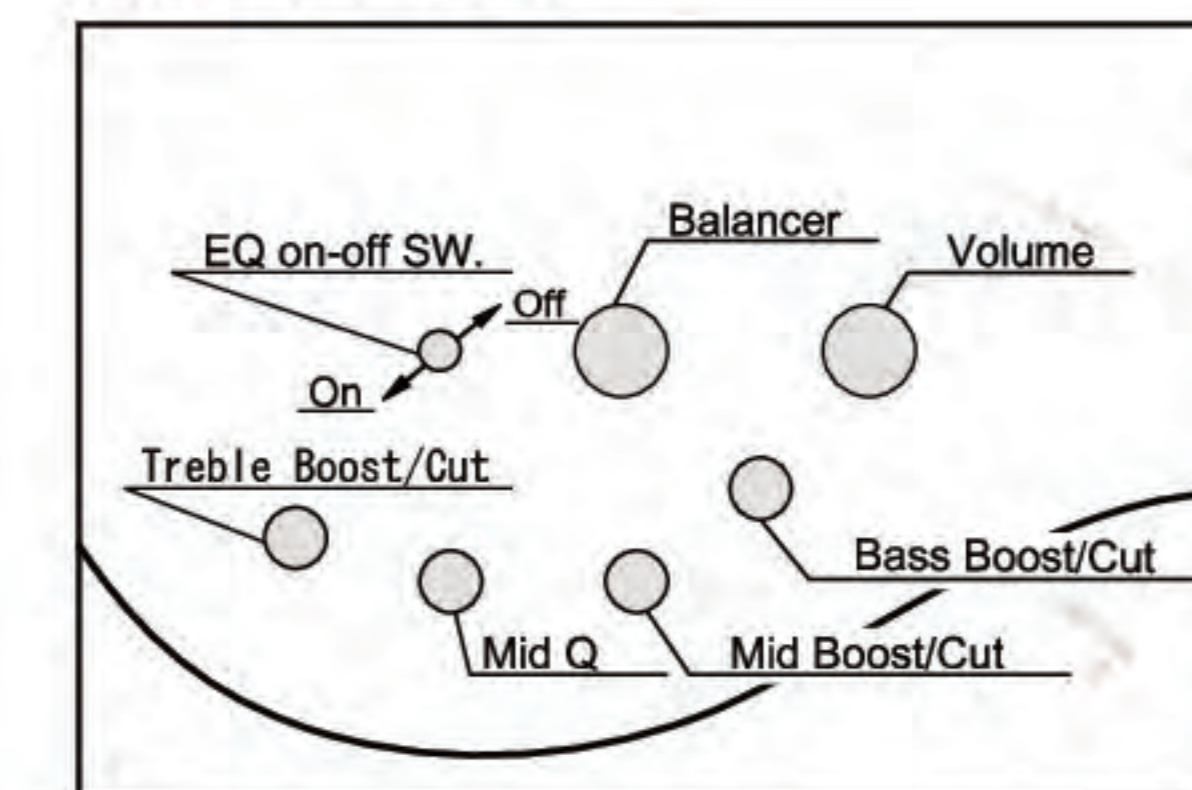

ATK N3 3-band EQ

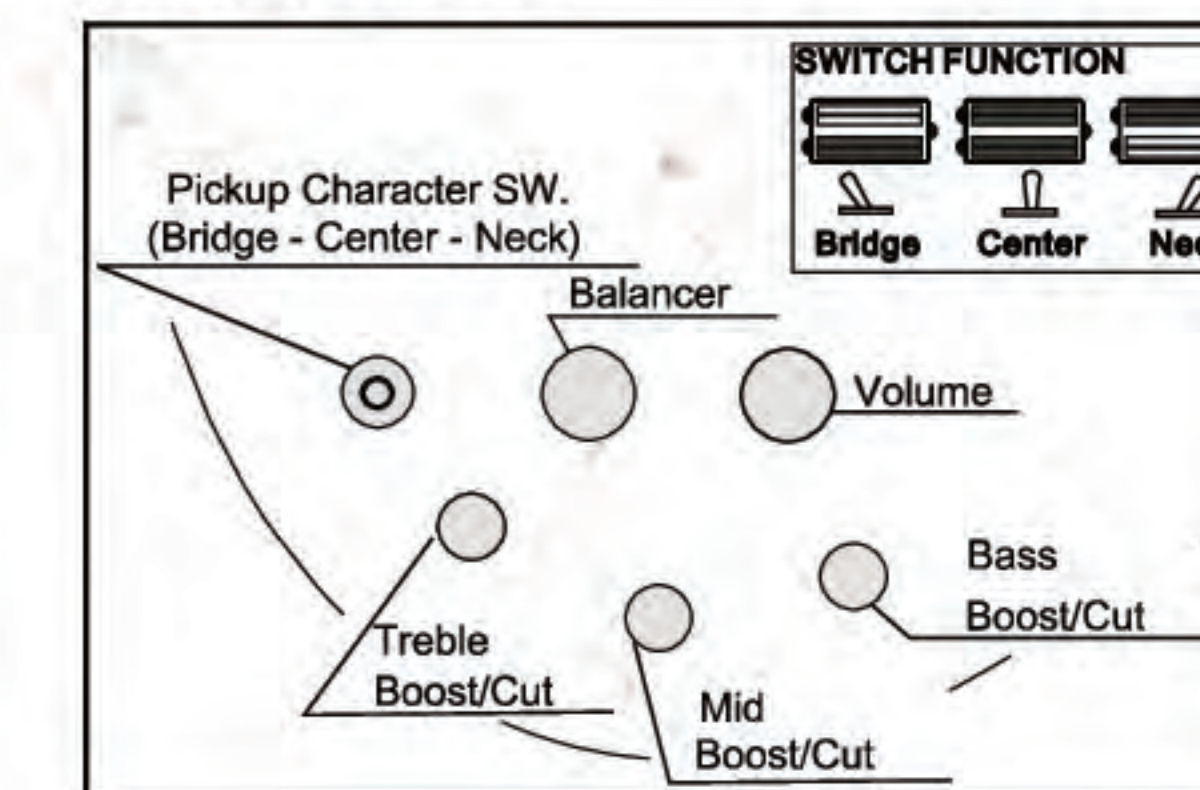

EQB-IIISC 3-band EQ

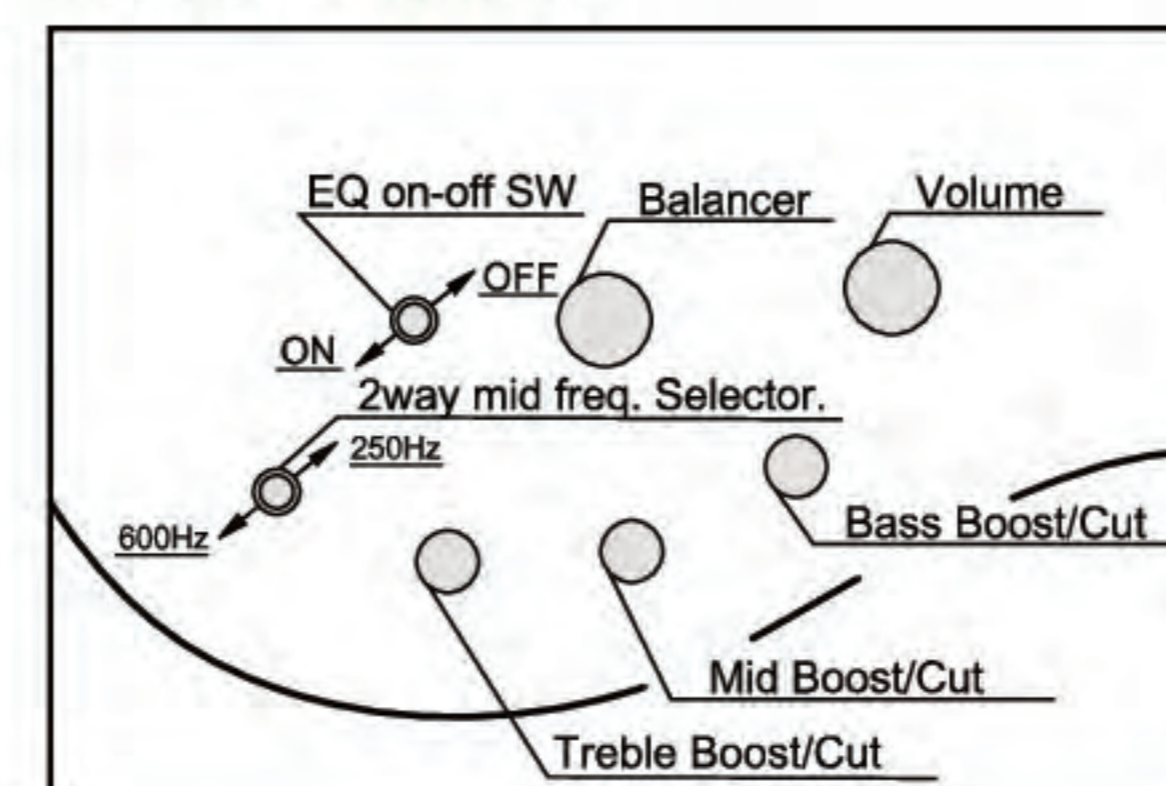

EQB-IIIS 3-band EQ

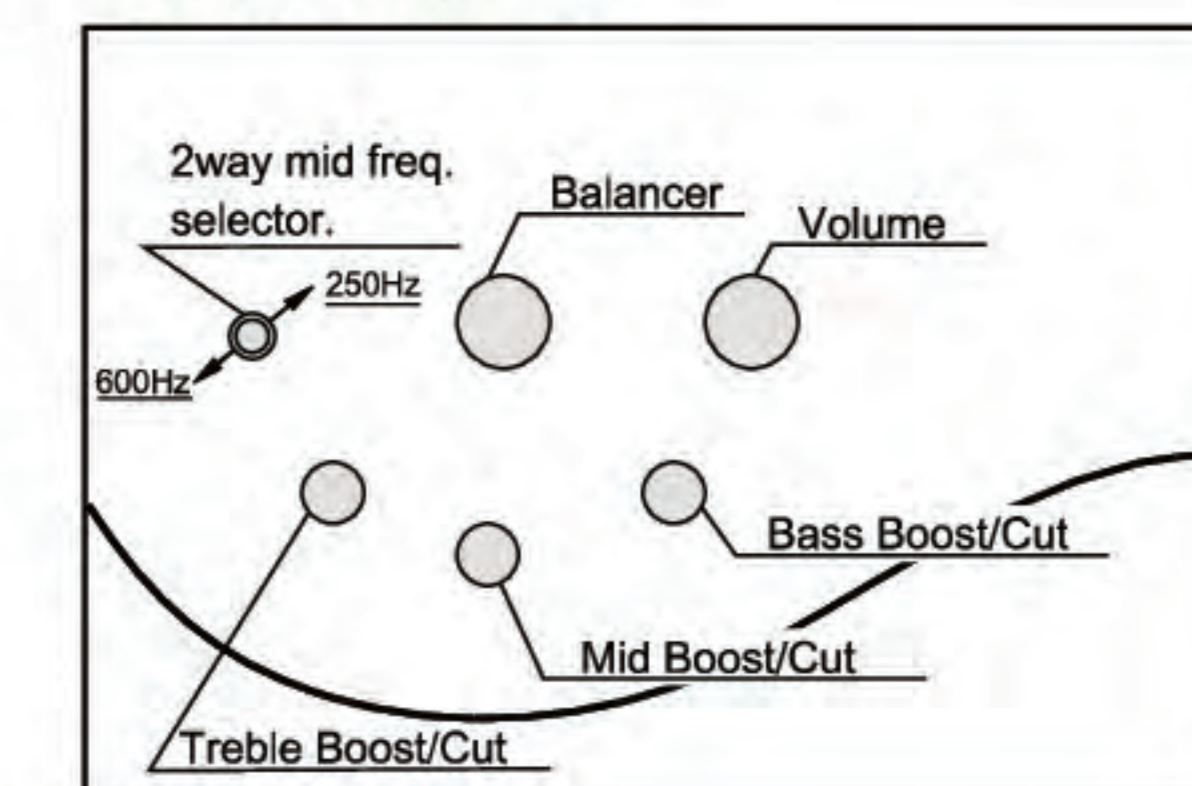

EQB-IIID 3-band EQ

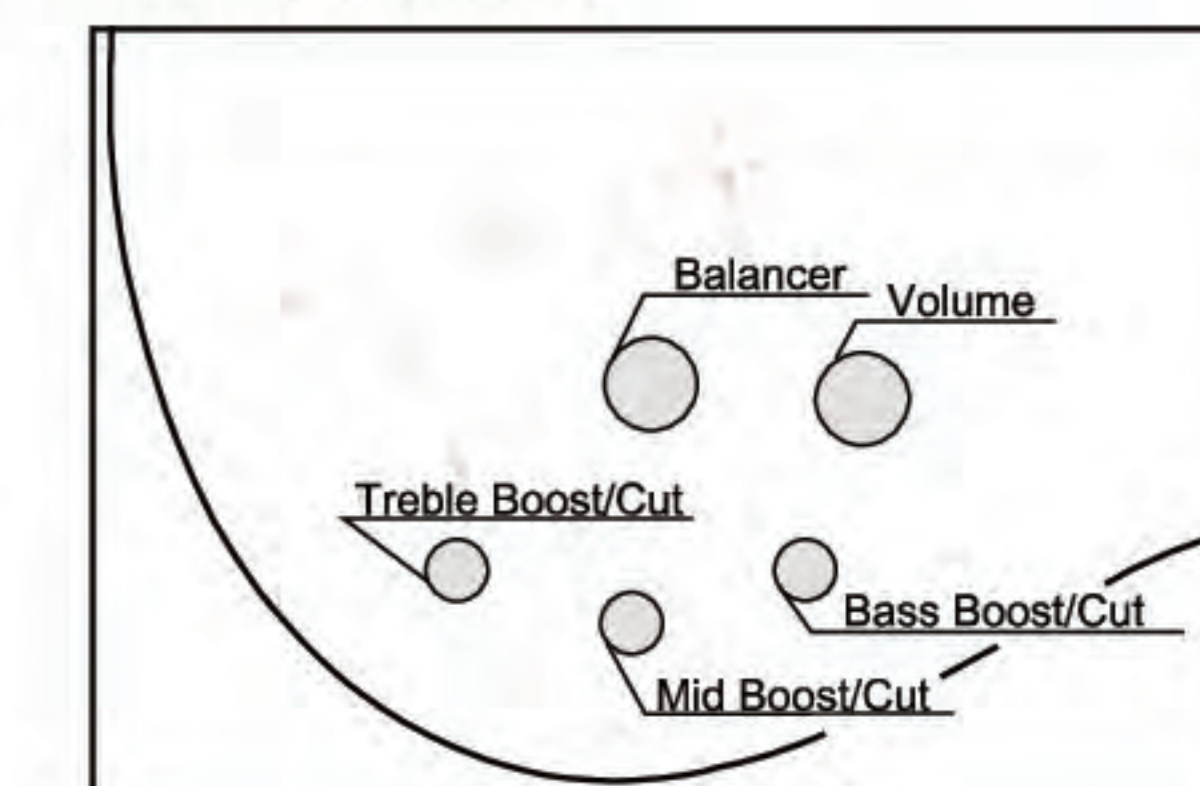

ATK N2 3-band EQ

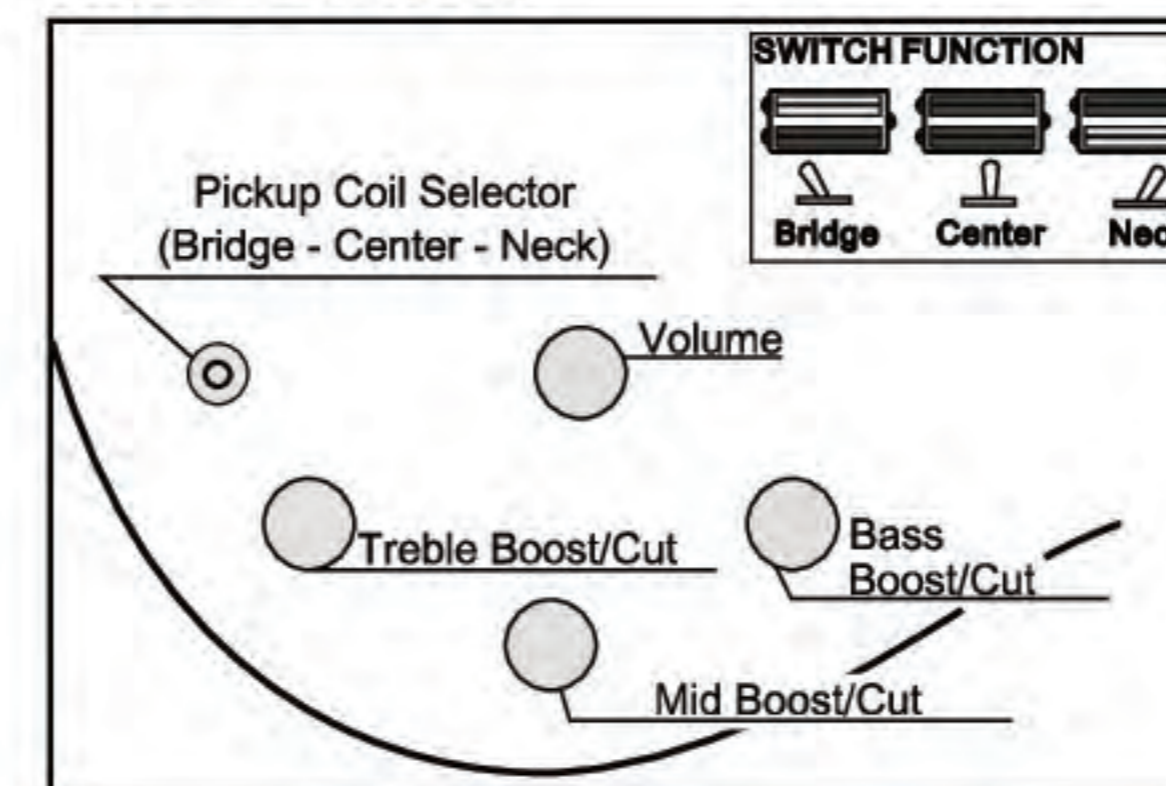

BEQIII 3band-EQ w/3way mid freq. selector

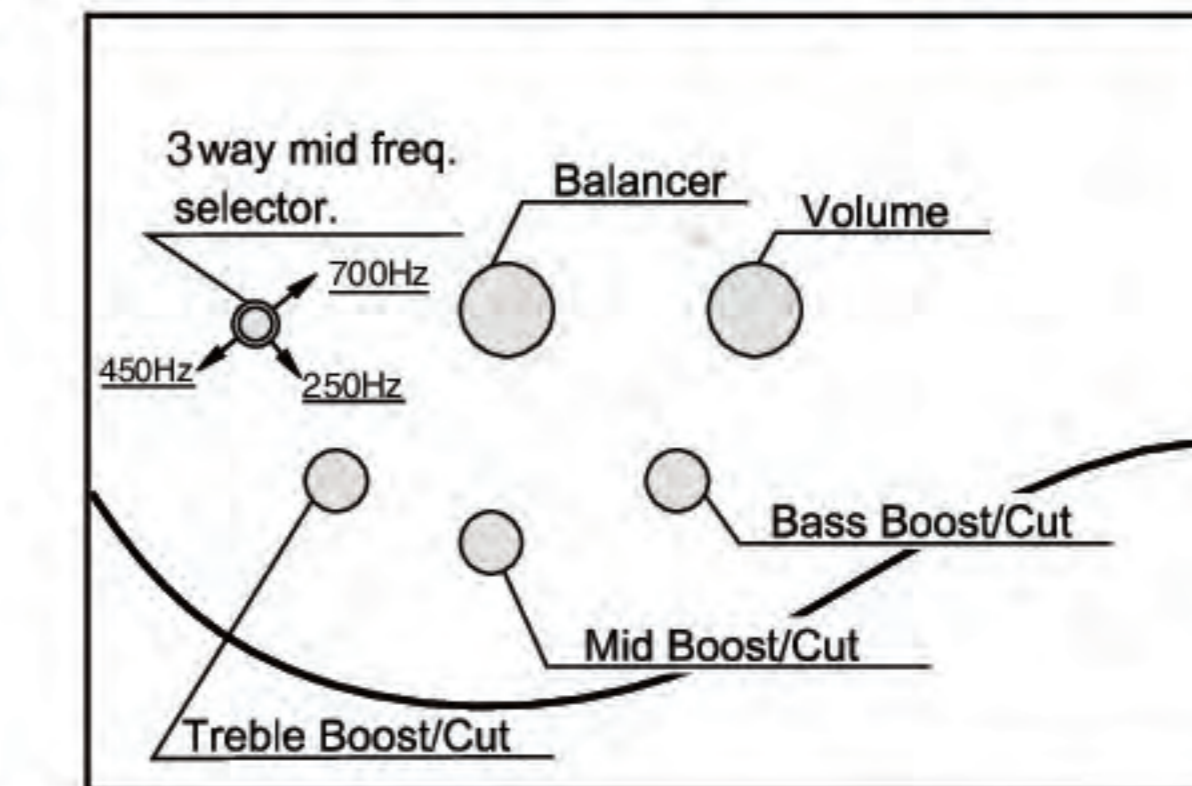

Artcore Bass Control

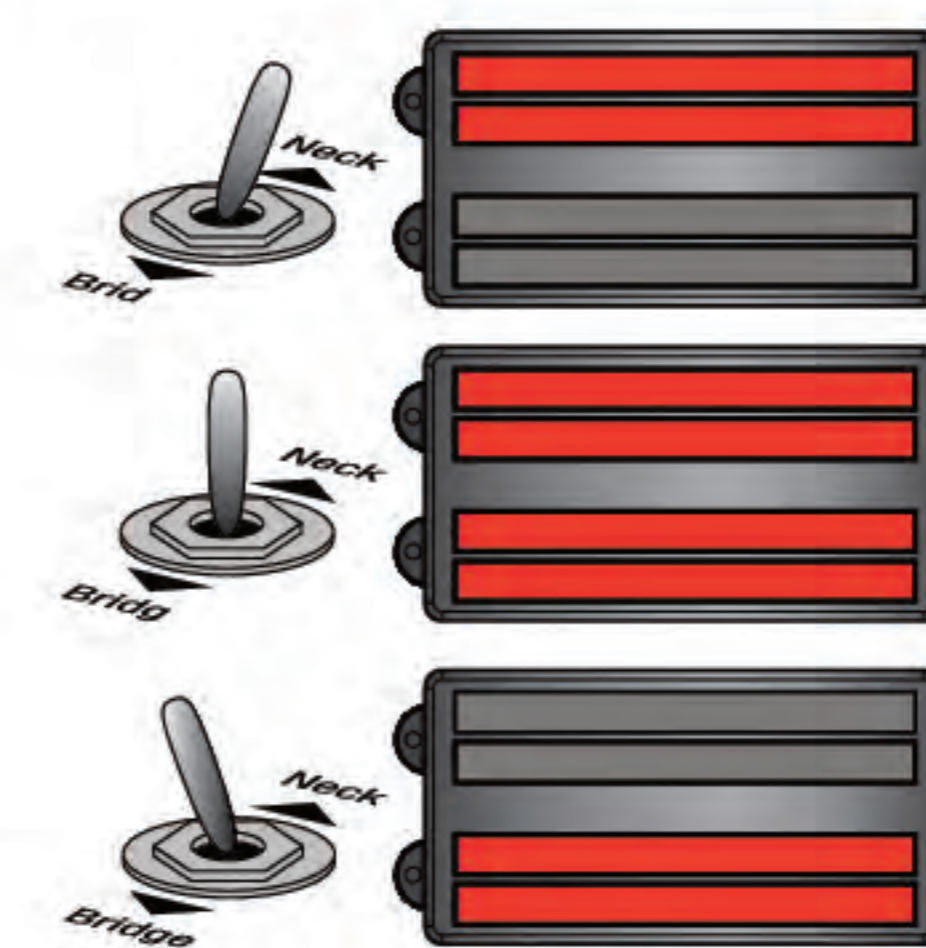
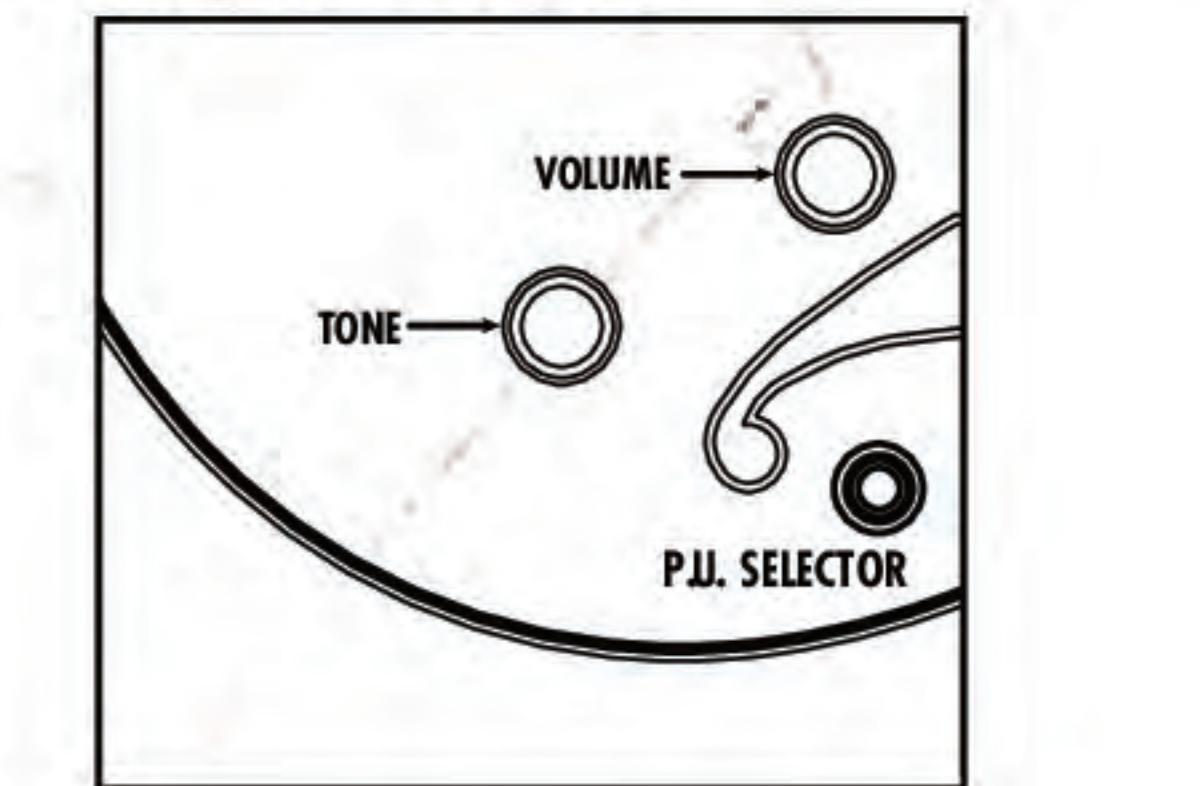

### CAP Double Humbucker Pickup(ATK)

CAP-DHピックアップはセラミック・マグネットを採用した3種類の特徴的なサウンドが得られるハムバックング・ピックアップ。

- ネック・ポジション  
ピックアップを多用するプレイヤーに最適なダイナミックなボトムとクリアなミッド・レンジが特徴
- ミドル・ポジション  
スラップに最適なファットかつ粒立ちの良いブライトなトーンが特徴
- ブリッジ・ポジション  
バンド・サウンドの中で埋もれない、スムーズなトラディショナル・サウンドが特徴

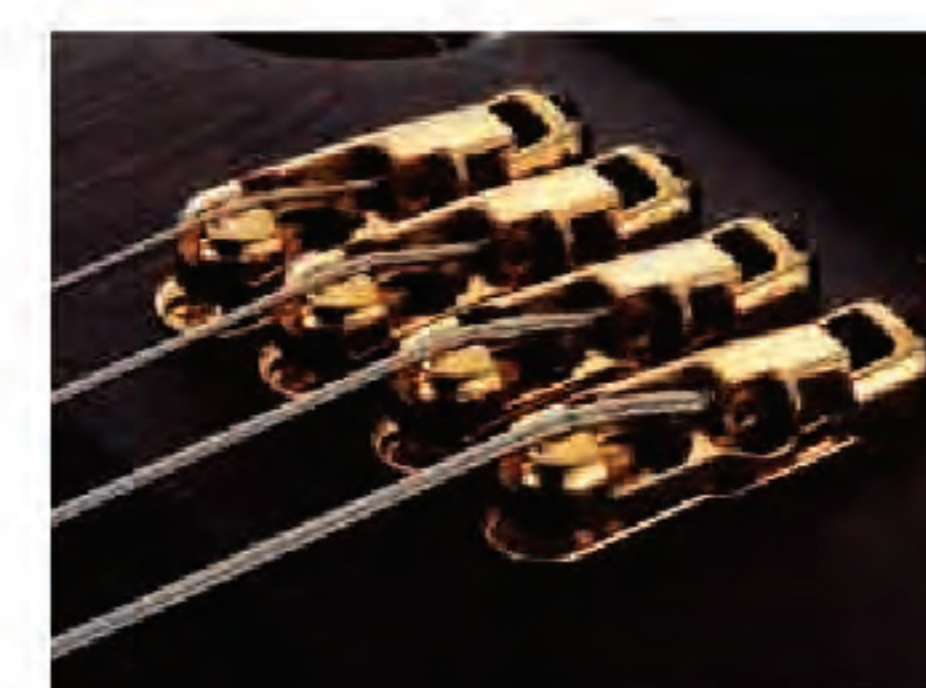

### MR-4 Mono-Rail Bridge / MR-2 Mono-Rail Bridge

他の弦の振動の影響をうけにくい、各弦独立構造のMono-Rail(モノレール)ブリッジ。サドルはブリッジ本体にスクリューで固定され、弦振動をより確実にボディへと伝達する。



### Tight-End Bass bridge

がっちりサドルが固定されたベースプレートとボディがフルコンタクトする事で、弦振動をロス無く伝えるハード・テイル・ブリッジ。材質をプラス製としたことで、特有の倍音溢れる音色を実現。(4弦用:弦間ピッチ 19mm、5弦用:弦間ピッチ 18mm、6弦用:弦間ピッチ 18mm)



### ATK Bridge

ATKならではの大きいベース・プレートと弦をボディ背面から通す構造のブリッジにより、弦振動をボディ本体へと豊かに伝達可能。





# Acoustic Guitars

## TABLE OF CONTENTS

Electric Guitars .....	P.2
Electric Bases .....	P.48
Acoustic Guitars .....	P.66
AEG / AEGB .....	P.68
AEL .....	P.70
ARTWOOD .....	P.72
GA / UEW .....	P.74
Amplifiers / Effects / Accessories .....	P.76



# AEG/AEGB

“全ての弾き手にとってパフォーマンスの負担にならず、抱えやすく取り回しの良いコンパクトなサイズ”がコンセプトのAEG。2013年モデルでは、ギターとしての演奏のしやすさや演奏の仕方に一層着目し、各部のサイズ、設計やスタイルを見直すと共に、ユニークなボディ・サイズのモデルもラインナップしました。



**RLV**  
(Resonant Natural Low Gloss Finish)

**OAB**  
(Open Pore Antique Brown Sunburst)  
¥73,500 (本体価格 ¥70,000)

## AEG4011

- Solid Spruce top, Flamed Maple back & sides body
- Mahogany neck
- Rosewood bridge and fretboard
- Fishman® Sonicore pickup
- Ibanez AEQ-SP1 preamp w/Onboard tuner
- Gold Die-cast tuners
- Ibanez Advantage™ bridge pins
- Abalone rosette
- string : .012~.053 Coated (D'Addario:EXP11)
- color : RLV (Resonant Natural Low Gloss Finish)  
OAB (Open Pore Antique Brown Sunburst)

## AEG2411

- Flamed Maple top, Mahogany back & sides body
- Mahogany neck
- Rosewood bridge and fretboard
- Fishman® Sonicore pickup
- Ibanez AEQ210TF preamp w/Onboard tuner
- Gold Die-cast tuners
- Ibanez Advantage™ bridge pins
- Abalone rosette
- string : .012~.053 Coated (D'Addario:EXP11)
- color : TGB (Transparent Gray Burst)  
THS (Transparent Hibiscus Red Sunburst)



**TGB**  
(Transparent Gray Burst)



**THS**  
(Transparent Hibiscus Red Sunburst)  
¥52,500 (本体価格 ¥50,000)

## AEG1011

- Spruce top, Mahogany back & sides body
- Mahogany neck
- Rosewood bridge and fretboard
- Fishman® Sonicore pickup
- Ibanez AEQ-SP1 preamp w/Onboard tuner
- Chrome Die-cast tuners
- Ibanez Advantage™ bridge pins
- Abalone rosette
- string : .012~.053 Coated (D'Addario:EXP11)
- color : BK (Black)  
TRS (Transparent Red Sunburst)



**BK**  
(Black)



**TRS**  
(Transparent Red Sunburst)  
¥39,900 (本体価格 ¥38,000)

## AEGB20E

- Flamed Maple top, Mahogany back & sides body
- Mahogany neck
- Rosewood bridge and fretboard
- Ibanez Under Saddle pickup
- Ibanez SPT Shape Shifter™ preamp w/Onboard tuner
- Chrome Die-cast tuners
- Ibanez Advantage™ bridge pins
- string : .045~.100 Round Wound (D'Addario:EXP170)
- color : VV (Vintage Violin)



**VV**  
(Vintage Violin)  
¥63,000 (本体価格 ¥60,000)



# AEL

厚さ100-125mmの大振りなボディから生み出される“ふくよかなサウンド”がコンセプトのAEL。弾き語りのボーカリストや、存在感あるサウンドを求めるギタリストに最適です。



**RLV**

(Resonant Natural Low Gloss Finish)  
¥68,250 (本体価格 ¥65,000)

## AEL40SE

- Solid Spruce top, Flamed Maple back & sides body
- Mahogany neck
- Rosewood bridge and fretboard
- Fishman® Sonicore pickup
- Ibanez SST Shape Shifter™ preamp w/Onboard tuner
- Gold Die-cast tuners
- Ibanez Advantage™ bridge pins
- Abalone rosette
- string : .012~.053 Coated (D'Addario:EXP11)
- color : RLV (Resonant Natural Low Gloss Finish)

## AEL30SE

- Solid Spruce top, Mahogany back & sides body
- Mahogany neck
- Rosewood bridge and fretboard
- Fishman® Sonicore pickup
- Ibanez SST Shape Shifter™ preamp w/Onboard tuner
- Gold Die-cast tuners
- Ibanez Advantage™ bridge pins
- Abalone rosette
- string : .012~.053 Coated (D'Addario:EXP11)
- color : BK (Black)

**BK**  
(Black)

¥63,000 (本体価格 ¥60,000)



## AEL15E

- Spruce top, Maple back & sides body
- Mahogany neck
- Rosewood bridge and fretboard
- Ibanez Under Saddle pickup
- Ibanez SPT Shape Shifter™ preamp w/Onboard tuner
- Chrome Die-cast tuners
- Ibanez Advantage™ bridge pins
- string : .012~.053 Coated (D'Addario:EXP11)
- color : BK (Black)
- THS (Transparent hibiscus red sunburst)
- TOS (Transparent ocean blue sunburst)

**BK**  
(Black)



**TOS**

(Transparent ocean blue sunburst)



**THS**

(Transparent hibiscus red sunburst)  
¥39,900 (本体価格 ¥38,000)



## AEL1512E

- Spruce top, Maple back & sides body
- Mahogany neck
- Rosewood bridge and fretboard
- Ibanez Under Saddle pickup
- Ibanez SPT Shape Shifter™ preamp w/Onboard tuner
- Chrome Die-cast tuners
- Ibanez Advantage™ bridge pins
- string : .010~.047 Coated (D'Addario:EXP36)
- color : NT (Natural)

**NT**  
(Natural)

¥52,500 (本体価格 ¥50,000)







# Artwood

伝統的かつ現代的、相反するふたつの要素を融合させたアコースティック・ギター、それがIbanezアートウッド・シリーズです。サウンドを重視したしっかりとした握り心地のUシェイブ・ネック。選び抜かれた高品質のエンゲルマン・スプルース/マホガニーのボディ材。効率良く弦振動をボディに伝え、かつ現代的にデザインされたブリッジ。そして、トラディショナルなネック・ジョイント方式と牛骨ナット&サドル。アートウッド・シリーズには透明感のあるアコースティック・サウンドと優れた演奏性を追求したこだわりが込められています。全ては奏者の思いに応えるために。



Bone Saddle



Grover® Machineheads and Bone Nut



Dovetail Neck Joint

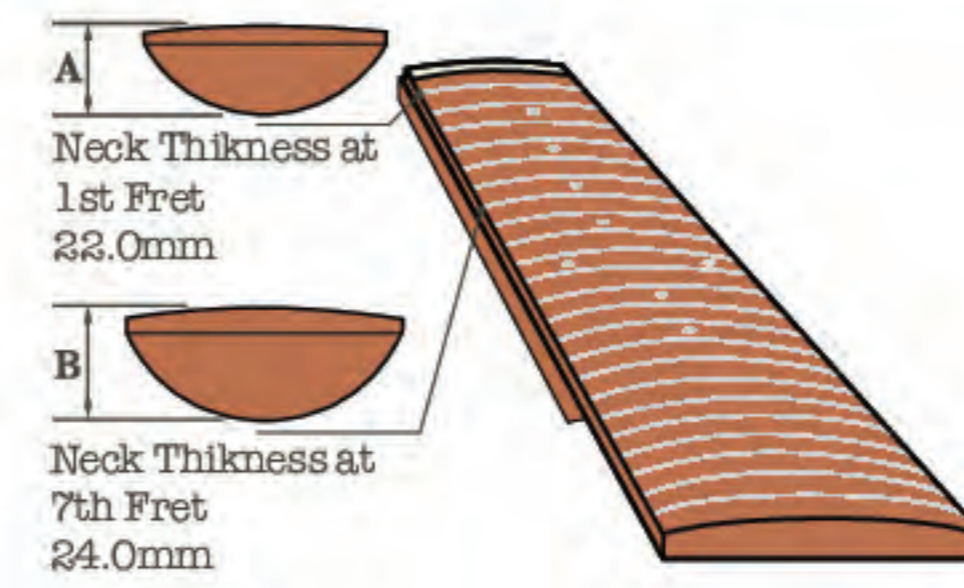

Neck Dimension



NT  
(Natural)  
¥66,150 (本体価格 ¥63,000)

## AC3000

- Solid Engelmann Spruce top, Solid Mahogany back & sides body
- Mahogany neck
- Rosewood bridge and fretboard
- Gold Grover® tuners w/Brown Pearl knobs
- Ibanez Advantage™ bridge pins
- Abalone rosette
- string : .012~.053 Coated (D'Addario:EXP11)
- color : NT (Natural)



NT  
(Natural)  
¥66,150 (本体価格 ¥63,000)

## AW3000

- Solid Engelmann Spruce top, Solid Mahogany back & sides body
- Mahogany neck
- Rosewood bridge and fretboard
- Gold Grover® tuners w/Brown Pearl knobs
- Ibanez Advantage™ bridge pins
- Abalone rosette
- string : .012~.053 Coated (D'Addario:EXP11)
- color : NT (Natural)



NT  
(Natural)  
¥38,850 (本体価格 ¥37,000)

## AC300

- Solid Engelmann Spruce top, Mahogany back & sides body
- Mahogany neck
- Rosewood bridge and fretboard
- Chrome Grover® tuners
- Ibanez Advantage™ bridge pins
- Abalone rosette
- string : .012~.053 Coated (D'Addario:EXP11)
- color : NT (Natural)



NT  
(Natural)  
¥38,850 (本体価格 ¥37,000)

## AW300

- Solid Engelmann Spruce top, Mahogany back & sides body
- Mahogany neck
- Rosewood bridge and fretboard
- Chrome Grover® tuners
- Ibanez Advantage™ bridge pins
- Abalone rosette
- string : .012~.053 Coated (D'Addario:EXP11)
- color : NT (Natural)



OPN  
(Open Pore Natural Finish)  
¥38,850 (本体価格 ¥37,000)

## AC240

- Solid Mahogany top, Mahogany back & sides body
- Mahogany neck
- Rosewood bridge and fretboard
- Chrome Grover® tuners
- Ibanez Advantage™ bridge pins
- Abalone rosette
- string : .012~.053 Coated (D'Addario:EXP11)
- color : OPN (Open Pore Natural Finish)



NT  
(Natural)  
¥52,500 (本体価格 ¥50,000)

## AW300ECE

- Solid Engelmann Spruce top, Mahogany back & sides body
- Mahogany neck
- Rosewood bridge and fretboard
- Fishman® Sonicore pickup
- Ibanez SST Shape Shifter™ preamp w/Onboard tuner
- Chrome Grover® tuners
- Ibanez Advantage™ bridge pins
- Abalone rosette
- string : .012~.053 Coated (D'Addario:EXP11)
- color : NT (Natural)



NT  
(Natural)  
¥52,500 (本体価格 ¥50,000)

## AC300ECE

- Solid Engelmann Spruce top, Mahogany back & sides body
- Mahogany neck
- Rosewood bridge and fretboard
- Fishman® Sonicore pickup
- Ibanez SST Shape Shifter™ preamp w/Onboard tuner
- Chrome Grover® tuners
- Ibanez Advantage™ bridge pins
- Abalone rosette
- string : .012~.053 Coated (D'Addario:EXP11)
- color : NT (Natural)





# GA

一人でも多くの人に気軽にガット・サウンドを楽しんでもらいたい、それがIbanezエレクトリック・ガット・ギター、GAシリーズに込められた願いです。即座にチューニングが可能なオンボード・チューナー、宅録ユースで便利なXLRアウトプット、ノイズ低減を実現するPHASEスイッチなど、手にしたその瞬間から多くのシーンで楽しんで頂ける実践的な仕様を備えています。

## GA37STCE

- Solid Spruce top, Sapele back & sides body
- Mahogany neck
- Rosewood bridge and fretboard
- Ibanez Under Saddle pickup
- Ibanez AEQ210T preamp w/Onboard tuner
- Gold Classic tuners
- color : DV (Dark Violin Sunburst)
- NT (Natural)
- TR (Transparent Red)



TR  
(Transparent Red)



NT  
(Natural)



DV  
(Dark Violin Sunburst)  
¥35,700 (本体価格 ¥34,000)

## GA40SFCE

- Solid Spruce top, Flamed Maple back & sides body
- Mahogany neck
- Rosewood bridge and fretboard
- Ibanez Under Saddle pickup
- Ibanez AEQ210T preamp w/Onboard tuner
- Gold Classic tuners
- color : AM (Amber)



AM  
(Amber)  
¥44,100 (本体価格 ¥42,000)

# Ukulele

思わず南国ハワイを想起してしまうウクレレ・サウンドを、Ibanezらしくエレクトロニカリーに楽しむ、そんなウクレレを世界に広めたい。これをコンセプトに提案するのがエレクトリック・ウクレレ、UEWシリーズです。

## UEW20SME

- Spalted Maple top/back/sides body
- Mahogany neck
- Rosewood bridge and fretboard
- Ibanez Under Saddle pickup
- Ibanez UK300-T preamp w/Onboard tuner
- Gold Grover® tuners
- Abalone rosette



¥26,250 (本体価格 ¥25,000)

## Body

Body Width, Depth and Length



AW

Width・Depth・Length  
400mm・125mm・505mm



AC

Width・Depth・Length  
388mm・106mm・494mm



AEL

Width・Depth・Length  
410mm・125mm・510mm



AEG / AEGB

Width・Depth・Length  
382mm・85mm・488mm  
382mm・70mm・488mm (AEG24II)



GA

Width・Depth・Length  
357mm・70mm・484mm (GA37)  
357mm・90mm・484mm (GA40)



UEW

Width・Depth・Length  
210mm・70mm・267mm

## Neck Dimensions

Neck Model	Scale Length	Fretboard Radius	Thickness at 1st Fret	Thickness at 7th Fret	Width at Nut	Width at 14th Fret
AEG	634mm	400mmR	20mm	21mm	43mm	55mm
AEGB20E	815mm	400mmR	21mm	23.5mm	43mm	58mm
AEL	650mm	250mm	20mm	21mm	42mm	54mm
AEL1512E	650mm	250mm	21mm	22mm	45mm	58mm
AW	648mm	300mmR	22mm	24mm	43mm	55mm
AC	634mm	300mmR	22mm	24mm	44.5mm	57mm
GA37STCE	650mm	FLAT	21mm	23mm	46mm	58mm
GA40SFCE	650mm	FLAT	22mm	24mm	52mm	63.5mm
UEW	378mm	FLAT	17.6mm	20.6mm	35mm	44mm

## Ibanez ADVANTAGE™ Bridge Pin

ボールエンドを常に正しい位置にセットすることが可能なIbanez ADVANTAGE™ Bridge Pin。



<従来のブリッジ・ピン>

弦のボールエンドがブリッジ・ピンの先端に引っかかりやすく、ピンが押し戻されてしまう。

<Ibanez ADVANTAGE™ Bridge Pin>

テーパ状に設定されたピンの先端がボールエンドを正しい位置へと導きます。



## Ibanez AEQ-SP1 Preamp w/Built-in tuner

Fishman® Sonicore ピックアップ用に開発された、Ibanez AEQ-SP1 プリアンプ。コントロール部とバッテリーボックスをコンパクトに一体化し、ギターボディ側面上部に搭載することで操作性を向上させています。シンプルな操作に加え、音作りの幅を広げる3バンドEQ、視認性の高いオンボード・チューナー、ハウリング対策のPHASEスイッチを搭載し、快適な演奏環境を作り上げることが可能です。(電池：006P×1)



## Ibanez SST Preamp w/Built-in tuner

Fishman® Sonicore ピックアップにあわせて開発したIbanez SST プリアンプ。簡単操作のコントロール・パネルに視認性の高いオンボード・チューナーを搭載しています。音作りの幅を広げる3バンドEQに加え、音全体の輪郭を調整するSHAPEコントロール、さらにはPHASEスイッチを搭載しハウリングに対する備えも万全です。(電池：単3乾電池×2)



## Ibanez SPT Preamp w/Built-in tuner

音作りの幅を広げる3バンドEQに加え、音全体の輪郭を調整するSHAPEコントロール、さらにはPHASEスイッチを搭載しハウリングに対する備えも万全です。オンボード・チューナーの搭載により常に安定した演奏環境を作り上げることが可能です。(電池：単3乾電池×2)



## Ibanez AEQ210T/AEQ210TF Preamp w/Built-in tuner

シンプルなサウンド・メイクが可能な2バンドのEQは、小型ボディのギターにありがちな低音域の不足を補うようキャラクター付けをしています。また、PHASEシフト・スイッチによりハウリングを防止、どんなシーンでも安心してプレイして頂けます。もちろん、オンボード・チューナーを内蔵しています。(電池：006P×1)



# Amplifiers Effects Accessories



## TABLE OF CONTENTS

Electric Guitars .....	P.2
Electric Bases .....	P.48
Acoustic Guitars .....	P.66
Amplifiers / Effects / Accessories .....	P.76
TUBE SCREAMER AMPLIFIER .....	P.78
promethean .....	P.80
IBZ / DA .....	P.82
TROUBADOUR .....	P.83
Effects / Tuner .....	P.84
Case / Bag .....	P.88
Cable / Strap / Stand .....	P.90
Pick .....	P.92



# Ibanez Guitar Amplifiers

## TUBE SCREAMER AMPLIFIER

Overdriveの代名詞としてエフェクター史にその名を刻むIbanez TUBE SCREAMER。そんなTUBE SCREAMERの回路を搭載した真空管アンプが、「Ibanez TUBE SCREAMER Amplifier」です。真空管アンプならではのナチュラルなクリーン・サウンドとキレの良いランチ・サウンドはもちろんのこと、現行のTS9サーキットをアンプ専用に変更したTUBE SCREAMERセクションを組み合わせることで獲得したウォームで心地よいオーバードライブ・サウンドをお楽しみ頂けます。



### TSA30

Guitar Combo Amplifier

¥72,450 (本体価格 ¥69,000)

- output power 30W@4Ω / 8Ω / 16Ω
- speaker unit 12" Celestion® Seventy80
- controls Boost/Normal Switch, TUBE SCREAMER On/Off Switch, Gain, Volume, Bass, Middle, Treble, TUBE SCREAMER Section: Overdrive, Tone, Level
- i/o's Input, Footswitch, Effect Loop (Send / Return), Speaker Output, External Speaker Output 2 outputs (4Ω / 8Ω / 16Ω switchable)
- cabinet Semi open back
- tube 12AX7 x 3, 6L6GC x 2
- size 478(W) x 445(H) x 265(D) mm
- weight 17.7kg



### IFS2G

Footswitch

¥4,200 (本体価格 ¥4,000)

TUBE SCREAMER セクションと BOOST 機能のオン / オフが可能です。フットスイッチが接続されていると、フロント・パネルの各スイッチは無効になります。

### Gain and Tone Control

クリーンで癖が少なくナチュラルなチューブ・サウンド。VOLUME と3バンドのトーン・コントロールでアンプ全体の音量とトーンを、GAIN とブースト・スイッチで歪みを調整することで、多彩で繊細なサウンドを作り出すことが可能。

### TSA30 control panel

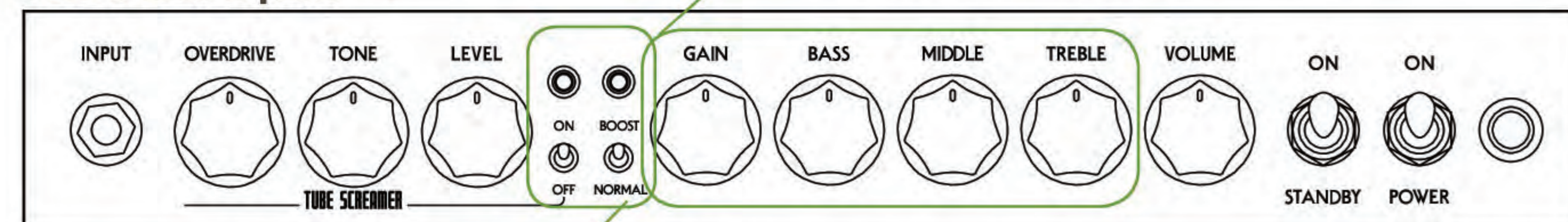

### Boost Switch

ONにすると6dbのゲインUPが可能。チューブのキャラクターをより濃くサウンドに反映。



### TSA15H

Guitar Amplifier Head

¥37,800 (本体価格 ¥36,000)

- output power 15W (5極管モード) or 5W (3極管モード) @8Ω
- controls Boost/Normal Switch, TUBE SCREAMER On/Off Switch, Volume, Bass, Treble, TUBE SCREAMER Section: Overdrive, Tone, Level, Output Mode Switch
- i/o's Input, Footswitch, Effect Loop (Send/Return) Speaker Output (2x4Ω, 2x8Ω, 1x16Ω)
- tube 12AX7 x 2, 6V6GT x 2
- size 368(W) x 172(H) x 200(D) mm
- weight 7.6kg

### TSA112C

Speaker Cabinet

¥24,150 (本体価格 ¥23,000)

- power handling 80W@8Ω
- speaker 12" Celestion® Seventy80
- i/o's Input 8Ω
- size 460(W) x 410(H) x 305(D) mm
- weight 13.0kg



### IFS2G

Footswitch

¥4,200 (本体価格 ¥4,000)

TUBE SCREAMER セクションと BOOST 機能のオン / オフが可能です。フットスイッチが接続されていると、フロント・パネルの各スイッチは無効になります。



### Speaker Outputs

バリエーションに富んだ出力端子を装備、大多数のキャビネットに接続可能。お気に入りのスピーカー・キャビネットでフル・チューブ・サウンドが楽しめる。

### Boost Switch

ONにすると6dbのゲインUPが可能。チューブのキャラクターをより濃くサウンドに反映。

### TSA15H control panel

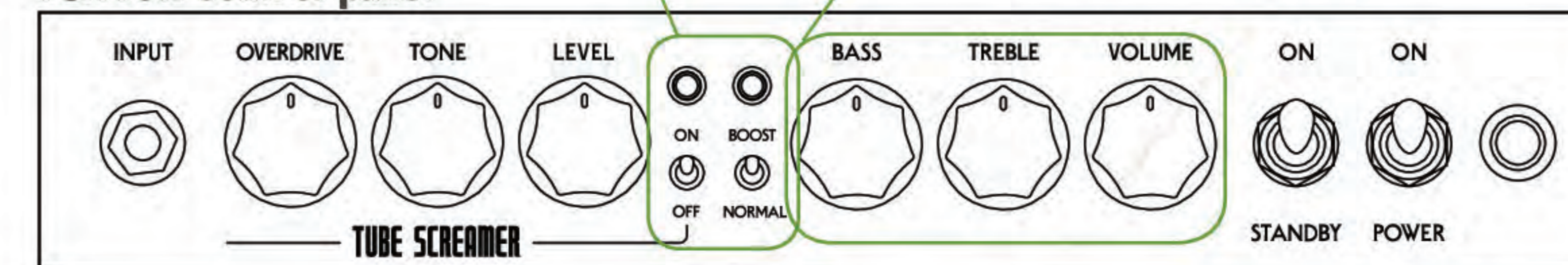

### Tone Control

クリーンで癖が少なくナチュラルなチューブ・サウンド。またコントロールもシンプルで2バンド・コントロール搭載。いわゆるMIDの設定は無いものの、主に中音域に強く作用するTUBE SCREAMERモードではDRIVEをカットしTONEを操る、あるいはボリュームを上げBASS/TREBLE共にカットの方向で操作することで十分にMIDのサウンドを反映させることが可能。



### TSA5 control panel

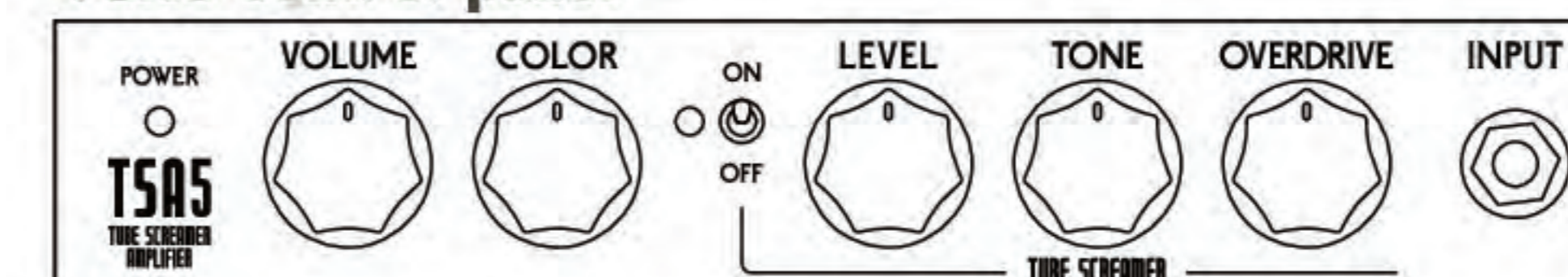

### TSA5

Guitar Combo Amplifier

OPEN PRICE

- output power 5W@8Ω
- speaker unit 10" Celestion® Tube10
- controls TUBE SCREAMER On/Off Switch, Volume, Color, TUBE SCREAMER Section: Overdrive, Tone, Level
- i/o's Input, Footswitch, External Speaker output 1 output (External Speaker Output / 8Ω)
- cabinet Semi open back
- tube 12AX7 x 1, 6V6GT x 1
- size 335(W) x 310(H) x 195(D) mm
- weight 7.9kg



### IFS1G

Footswitch

¥2,625 (本体価格 ¥2,500)

TUBE SCREAMER セクションのオン / オフが可能です。フットスイッチが接続されていると、フロント・パネルの各スイッチは無効になります。



# Ibanez Bass Amplifiers

## PROMETHEAN

こんな小さなアンプで大音量が出せるものか、と訝る人がいるかもしれません。けれども、ギリシャ神話の火の神"プロメテウス"にあやかって名付けられたpromethean(プロメシアン)ならば、不可能なことではありません。会場から会場へと飛び回るワーキング・ミュージシャンのために開発されたprometheanは、そのコンパクト・ボディの中に様々なシチュエーション、ライブ環境での要求に応える為のプレイヤー本位の機能を多数備えながら、300W@4Ωのアウトプット・パワーを備えています。

多くの現役ミュージシャン達からも支持される、そのサイジング、ファンクション、そしてサウンドは常に傍らに置く相棒として何ら不足は無いと断言します。



### Limiter On/Off Switch

リミッター・スイッチをONにすると、強くビッキングした際などにパワーアンプが歪まない程度に信号レベルを抑えることが可能。



### 3 Band Tone Control & Phat Control

それぞれ、低音域/中音域/高音域のブースト/カットをコントロールする3バンドEQを搭載。またスラップ・プレイに適した音色が簡単に得られるのがファット・コントロール。コントロール・ノブを時計回りにまわすと、中音域をカットしつつ、低音域/高音域をブーストすることが可能。



### P300H

Bass Amplifier Head

¥39,900 (本体価格 ¥38,000)

- output power 300W@4Ω, 150W@8Ω
- controls Gain, High, Mid, Low, Phat, Master, Limiter On / Off Switch
- i/o's Input, AUX Input, Headphones Out, Balanced Line Out(XLR), Speaker Out (1/4" x 2)
- size 240(W) x 54(H) x 230(D) mm
- weight 2.3kg



### P3115

Bass Combo Amplifier

¥55,650 (本体価格 ¥53,000)

- output 300W @4Ω
- speaker 15" Speaker, Piezo Tweeter
- controls Gain, High, Mid, Low, Phat, Master, Limiter On / Off Switch
- i/o's Input, AUX Input, Headphones Out, Balanced Line Out(XLR)
- cabinet Closed back
- size 437(W) x 522(H) x 390(D) mm
- weight 17.0kg



### NEW MODEL

### P3110D

Bass Combo Amplifier

¥50,400 (本体価格 ¥48,000)

- output power 300W @4Ω
- speaker unit 10" Speaker, Piezo(Coaxial) Tweeter
- controls Gain, High, Mid, Low, Phat, Master, Limiter On / Off Switch
- i/o's Input, AUX Input, Headphones Out, Balanced Line Out(XLR)
- cabinet Closed Back Cabinet w/ Tilt-up bar
- size 320(W) x 345(H) x 310(D) mm
- weight 10.5Kg

\*このキャビネットを用いてのシステム拡張はできません。



### P410CC

Speaker Cabinet

¥63,000 (本体価格 ¥60,000)

- power handling 250W@8Ω
- speaker 4x10" Speaker, Horn Tweeter
- i/o's 1/4" jack x 2
- cabinet Ported Cabinet
- size 620(W) x 620(H) x 400(D) mm
- weight 33.2kg



### P115CC

Speaker Cabinet

¥50,400 (本体価格 ¥48,000)

- power handling 250W@8Ω
- speaker 15" Speaker, Horn Tweeter
- i/o's 1/4" jack x 2
- cabinet Ported Cabinet
- size 620(W) x 470(H) x 400(D) mm
- weight 24.5kg



# IBZ10W AMPS

- Ibanez プラクティス・アンプ、IBZ10G、IBZ10B。  
プラグ・インしたその瞬間から、  
本格的なギター/ベース・サウンドを楽しめます。
- それぞれに6.5インチ・オリジナル・スピーカーを搭載。10Wながら迫力溢れるサウンド。
  - 使いやすさを追求したシンプルなコントロール。
  - 3.6kgの軽量コンパクト・ボディ。
  - ヘッドフォン端子、AUX端子付。



**IBZ10G** Guitar Amplifier

### OPEN PRICE

• output power	10W@4Ω
• speaker unit	6.5" speaker
• controls	Distortion On/Off Switch, Gain, Bass, Treble, Volume
• i/o's	Guitar Input, Headphone, AUX Input
• cabinet	Closed Back
• size	255(W) x 275(H) x 174(D) mm
• weight	3.6kg



**IBZ10B** Bass Amplifier

### OPEN PRICE

• output power	10W@4Ω
• speaker unit	6.5" speaker
• controls	Bass, Middle, Treble, Volume
• i/o's	Bass Input, Headphone, AUX Input
• cabinet	Closed Back
• size	255(W) x 275(H) x 174(D) mm
• weight	3.6kg

# DESKTOP AMPS

デスクに置いたり、時には外にも持ち運べるコンパクト・サイズ。アダプターは勿論、006P乾電池駆動のも可能なことから命名されたデスクトップ・アンプ、DAG1、DAB1。

- ワンタッチで、ギター用はヘヴィなディストーション・サウンドを、ベース用はミッド・ブースト効果が得られるHOTモード・スイッチを搭載。
- デジタル・オーディオ・プレイヤーやその他再生デバイスを繋げば、音楽に合わせて演奏することが可能。(HOT, EQ部バイパス)
- ヘッドフォン端子付き。



**DAG1** Desktop Guitar Amplifier

¥4,725 (本体価格 ¥4,500)

• output power	1.6W@8Ω
• speaker unit	3" speaker
• controls	Distortion On/Off Switch, Treble, Contour, Volume
• i/o's	Guitar Input, Headphone, CD Input
• size	102(W) x 116(H) x 63(D) mm
• power source	9V (006P) 乾電池 (別売) または付属専用ACアダプター

**DAB1** Desktop Bass Amplifier

¥4,725 (本体価格 ¥4,500)

• output power	1.6W@8Ω
• speaker unit	3" speaker
• controls	Mid-Boost On/Off Switch, Treble, Contour, Volume
• i/o's	Bass Input, Headphone, CD Input
• size	102(W) x 116(H) x 63(D) mm
• power source	9V (006P) 乾電池 (別売) または付属専用ACアダプター

# Ibanez Acoustic Guitar Amplifiers TROUBADOUR

カフェや比較的小さなライブハウスで演奏するとき、多くのプレイヤーにとってステージへ持ち込むアコースティック・アンプに最も必要なことは何でしょうか? 「深くしみわたるような、自然な鳴り」だと答える人がいるかもしれません。そして「持ち運びやすさ」と答える人も多いのではないのでしょうか。まるでハンド・クラフトのブティック・アンプのような落ち着いた雰囲気を持つTroubadour(トルバドール)はそんなプレイヤーに最適なアコースティック・ギター・アンプといえます。例えば近くのカフェ・ライブで弾く。例えばパーティ会場でかき鳴らす。そんなとき、Troubadourのサウンドがきくと部屋中を満たしてくれるでしょう。Troubadourは「サウンド」と「ポータビリティ」を追求してデザインされているのだから。



**NEW MODEL T15** Acoustic Guitar Combo Amplifier

¥13,650 (本体価格 ¥13,000)

• output power	15W@6Ω
• speaker unit	6.5" Full Range Speaker
• controls	Volume, Bass, Treble, Chorus On/Off
• i/o's	Guitar input, Headphone out
• cabinet	Closed back w / Tilt up System
• size	240(W) x 230(H) x 160(D) mm
• weight	2.9kg / 6.4lbs



**T30** Acoustic Guitar Combo Amplifier

¥26,250 (本体価格 ¥25,000)

• output	30W@8Ω
• speaker	8" Coaxial Speaker(with tweeter)
• controls	Guitar Channel : Volume, Bass, Treble, Chorus Speed On/Off Switch, Microphone Channel : Volume, Bass, Treble, Reverb, Master Volume
• i/o's	Guitar Input, Microphone Input(XLR), Headphone out, AUX Input
• cabinet	Closed Back with Tilt-up System
• size	338(W) x 270(H) x 240(D) mm
• weight	6.9kg



**IFS2U** Footswitch

¥4,200 (本体価格 ¥4,000)

T150S/T80N 用のフットスイッチ。  
A : Channel 1 Chorus / Reverb  
B : Channel 2 Chorus / Reverb  
C : Mute / Phase Invert / Notch Filter の機能がコントロール可能。



**T80N** Acoustic Guitar Combo Amplifier

¥39,900 (本体価格 ¥38,000)

• output	80W@8Ω
• speaker	10" Coaxial Speaker(with tweeter)
• controls	Volume, Treble, Middle, Bass, Chorus, Reverb, Notch Filter, Master Volume, AUX Volume, Level Switch, Phantom On/Off Switch, Phase Invert Switch, Mute Switch
• i/o's	2x1/4" Input, 2x XLR Input, AUX Input, Headphones Out with Stereo FX, Line-Out(Left), Line-Out(Right), 3xFootswitch-Input
• cabinet	Closed Back with Tilt-up System
• size	340(W) x 335(H) x 305(D) mm
• weight	9.2kg



**T150S** Acoustic Guitar Combo Amplifier

¥57,750 (本体価格 ¥55,000)

• output	2 x 75W@6Ω
• speaker	2x6.5" Coaxial(Stereo) Speaker(with tweeter)
• controls	Volume, Treble, Middle, Bass, Chorus, Reverb, Notch Filter, Master Volume, AUX Volume, Level Switch, Phantom On/Off Switch, Phase Invert Switch, Mute Switch
• i/o's	2x1/4" Input, 2x XLR Input, AUX Input, Headphones Out with Stereo FX, Line-Out(Left), Line-Out(Right), 3xFootswitch-Input
• cabinet	Closed Back with Tilt-up System
• size	364(W) x 270(H) x 280(D) mm
• weight	8.8kg



# TUBE SCREAMER

1970年代から現在に至るまで、オーバードライブの代名詞として、多くのギタリストに愛用され続けているTUBE SCREAMERシリーズ。TS808やTS9を筆頭にベース用TS9Bまでバリエーション・モデルをラインナップしています。



**TS808HW** TUBE SCREAMER  
¥54,600(本体価格¥52,000)

■コントロール: OVERDRIVE, TONE, LEVEL  
オーバードライブの代名詞として、1970年代から現在に至るまで多くのプレイヤーを魅了し続けるチューブスクリーマー。その輝かしい歴史に新たな1ページを刻む究極のチューブスクリーマーこそTS808HWに他ならない。選り抜かれた線材や内部パーツ、そして「ハンドワイヤリング」で実現する至高のオーバードライブ・サウンドを是非堪能してほしい。(1/8"ミニプラグ変換コード付属)  
9V(006P)乾電池×1駆動  
AC509 ¥2,205(本体価格¥2,100) \*別売



**TS808** TUBE SCREAMER  
¥19,425(本体価格¥18,500)

■コントロール: OVERDRIVE, TONE, LEVEL  
1970年代後半に海外で発売され、多くのプロ・ミュージシャンに愛用された伝説のコンパクト・エフェクターTUBE SCREAMER Overdrive Pro TS808のリイシュー・モデル。粘りある中音域と激し過ぎない柔らかな歪みは、このモデルにしか出せない味わいと言える。(復刻版オーナーズ・マニュアル、1/8"ミニプラグ変換コード付属)  
9V(006P)乾電池×1駆動  
AC509 ¥2,205(本体価格¥2,100) \*別売



**TS9** TUBE SCREAMER  
¥14,175(本体価格¥13,500)

■コントロール: DRIVE, TONE, LEVEL  
オーバードライブの代名詞とも呼べるTS9 チューブスクリーマー。ウォームで粘りあるオーバードライブ・サウンドは第一線で活躍する多くのプレイヤーにジャンルを超えて愛され続けている。  
9V(006P)乾電池×1駆動  
AC509 ¥2,205(本体価格¥2,100) \*別売



**TS9DX** TUBE SCREAMER  
¥17,325(本体価格¥16,500)

■コントロール: DRIVE, LEVEL, TONE, MODE(TURBO/HOT+/TS9)  
TS9DX ターボ・チューブスクリーマーは、ノーマルのTS9 サウンドに加え、TS9 よりも少しざらついた歪みの「+(プラス)」、中音域をブーストさせる「HOT」、より現代的かつパワフルな歪みを得るために中低音域を強力にブーストさせる「TURBO」の計4種の歪みモードを用意したデラックス仕様モデル。  
9V(006P)乾電池×1駆動  
AC509 ¥2,205(本体価格¥2,100) \*別売



**TS9B** BASS TUBE SCREAMER  
¥17,325(本体価格¥16,500)

■コントロール: OVERDRIVE, MIX, BASS, TRBLE  
ベース専用のTUBE SCREAMER。BASSとTREBLE、2つのコントロールに加え、クリーン成分とディストーション成分とのMIX比を調節可能にすることでベース用オーバードライブにありがちな「輪郭を失った歪み」を回避しやすくなるMIXコントロールを搭載。  
9V(006P)乾電池×1駆動  
AC509 ¥2,205(本体価格¥2,100) \*別売

# WH10V2

ギター用としてもベース用としても対応するレンジ切り替え方式を採用したワウ・ペダル、WH10V2。レンジの広さと掛かり具合の良さ、可変幅の広さなどの点から脚光を浴びた初代WH10のサウンド/機能はそのままに、アルミダイキャストボディを採用したことで耐久性が格段に向上。周波数域によってゲインの量も変化する一般的なインダクティブ・タイプのワウ・ペダルと違い、オペアンプによる増幅回路を用いることで、どの周波数域においても同じゲインを保つ。さらに、随所に盛り込んだバッファ回路でワウの宿命とも言える音ヤセを防止している。

**WH10V2** Classic Wah Pedal  
¥13,125(本体価格¥12,500)

■controls  
■switches  
■i/o's  
■size  
■power source

DEPTH  
Effect ON/OFF, Frequency range(GTR/BASS)  
INPUT, OUTPUT, DRY OUT  
87(W) x 82(H) x 202(D) mm  
9V (006P) 乾電池×1駆動  
AC509 ¥2,205(本体価格¥2,100) \*別売



# 9 series

TUBE SCREAMERシリーズだけでなく、数多の定番モデルを輩出してきた9シリーズに、SD9M(Sonic Distortion Mod.)、JD9(Jet Driver)、BB9(Bottom Booster)の3機種を加え、Ibanezの歪み系エフェクターはより充実したラインナップとなりました。



**BB9** Bottom Booster  
¥14,490(本体価格¥13,800)

■コントロール: GAIN, TONE, LEVEL  
クリーン・トーンを基調としつつ歪みパートをも重要視されるポップ・ロックや、曲を通じて音量感・音圧感と共に適度な歪みが求められるハード・ロックのジャンルで活躍するギタリストに最適な、ステージ向け即戦力ブースター。大型キャビネットの複数台スタック使用などプロの現場で求められる許容量の大きな機材を十分に鳴らすことを想定した高出力設定。トゥルー・バイパス仕様。  
9V(006P)乾電池×1駆動  
AC509 ¥2,205(本体価格¥2,100) \*別売



**SD9M** Sonic Distortion Mod.  
¥14,490(本体価格¥13,800)

■コントロール: DIST., TONE, LEVEL  
往年の名機と名高いSonic Distortionを、さらに現代的ディストーションへ昇華させるMid/Gain 2つのモード・スイッチを追加した「SD9M」。  
9V(006P)乾電池×1駆動  
AC509 ¥2,205(本体価格¥2,100) \*別売



**JD9** Jet Driver  
¥13,440(本体価格¥12,800)

■コントロール: DRIVE, MID, VOLUME, TONE  
粒立ちの良い上質なディストーション・サウンドを追求した、ロック・ミュージック指向ペダル。TONEに加えMIDコントロールを備えることでディストーションのアレンジ幅を拡大、クラシック・サウンドから現代的なハード・ロックまで幅広くマッチする。トゥルー・バイパス仕様。  
9V(006P)乾電池×1駆動  
AC509 ¥2,205(本体価格¥2,100) \*別売

# WEEPING DEMON

現代のミュージック・シーンに求められる多彩なサウンド、そしてさまざまな奏法用途に応える新機構のギター/ベース兼用ワウ・ペダル、WD7-Weeping Demon。フット・スイッチのオン/オフによって、好きなペダルの角度でエフェクトのオン/オフが行えるFOOT SWモードと、ペダルを踏み始めると自動的にエフェクト・オンになり、足を離せば自動的にオフになるAUTO SWモードを選ぶことができる画期的なレバー・スイッチ構造。そして安定したペダル・アクションとノイズレス環境を実現する光学方式を採用したペダル。ギターの周波数帯域と、ベースや7弦ギターの周波数帯域とを切り替えるRANGEスイッチを搭載し、また豊富なコントロールにより、ヴィンテージ風ワウ・サウンドから、ロー・パス・フィルターによる野太いワウ・サウンド、さらにはピークを持ち上げた過激なワウ・サウンドまで、容易にサウンドメイクが可能。

**WD7** Weeping Demon  
¥14,490(本体価格¥13,800)

■controls  
■i/o's  
■size  
■power source

LEVEL, AUTO OFF DELAY, Q, LO, RANGE FINE TUNING, Foot SW, MODE Lever  
INPUT, OUTPUT  
154(W) x 117(H) x 259(D) mm  
9V (006P) 乾電池×1駆動  
AC509 ¥2,205(本体価格¥2,100) \*別売

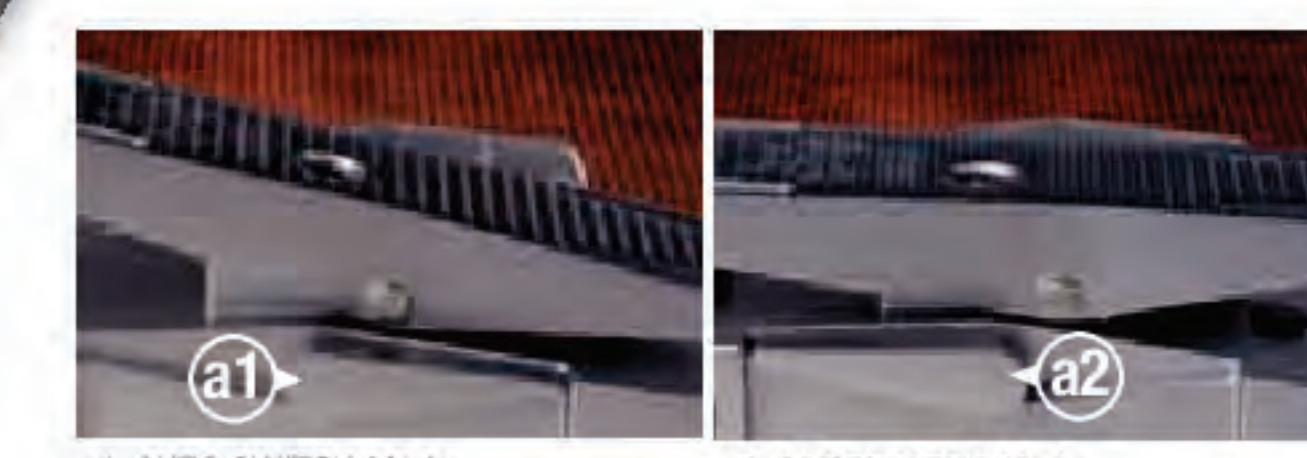

a1. AUTO SWITCH Mode a2. FOOTSWITCH Mode

**Mode Lever**  
FOOT SWモード/AUTO SWモードの切り替えを行います。  
a1. AUTO SWモード  
フットスイッチによってエフェクトのオン/オフをおこないます。  
a2. FOOT SWモード  
ペダルを踏み始めると自動的にエフェクト・オン、足を離せば自動的にオフになります。



# Echo Shifter

## Analog delay pedal

BBD (Bucket Brigade Device) 素子によるアナログ・ディレイに加え、強烈な発振を可能にするOSCILLATION、コーラスからピッチシフト・サウンドまでカバーするMODULATION、タップテンポ等多彩な機能を、ウッド・サイドウォールとスライドノブのクラシカルなデザインで包みました。アナログ×デジタルのヴァーサティリティが、プレイヤーを無限の世界へ誘うでしょう。

### NEW MODEL ES2

Analog Delay

¥17,850 (本体価格 ¥17,000)

• controls	FEEDBACK w/ OSCILLATION ON/OFF, DEPTH w/ MODULATION ON/OFF, MIX, TAP, DELAY TIME
• delay time	30ms - 1000ms
• size	120(W) x 65(H) x 160(D) mm
• weight	600g
• power source	9V (006P) 乾電池 x1 駆動 AC509 ¥2,205 (本体価格 ¥2,100) *別売



# Paul Gilbert Signature Flanger

## AIRPLANE FLANGER

Ibanez が Paul Gilbert のアイデアを基に完成させたペダル、その名も "AIRPLANE FLANGER"。Paul Gilbert 自身によってデザインされた筐体とユニークなネーミングのこのフランジャー・ペダルはスイッチひとつで2つのサウンドを使い分けることが可能。ひとつはオーソドックスなコーラス/フランジャーとして、そしてもう一つは Paul Gilbert お得意のまるで爆撃機のような激しいジェット・サウンドを楽しめるペダルです。



### AF2 Paul Gilbert Signature Flanger "AIRPLANE FLANGER"

¥24,150 (本体価格 ¥23,000)

• modes	TAXI : Flange/Chorus Type Modulation Effect TAKEOFF : Jet Sound (shifting pitch up and down)
• controls	MANUAL : Delay Time, SPEED : Modulation Speed, RANGE : Depth of Modulation ENHANCE : Feedback, EFFECT ON/OFF Switch, TAXI/TAKEOFF Switch
• i/o's	INPUT/OUTPUT (Mono)
• size	180(W) x 65(H) x 134(D) mm
• power source	専用ACアダプター付属

# DC Splitter Cords



### AC509

¥2,205 (本体価格 ¥2,100)

Ibanez のコンパクト・エフェクターに使用可能な AC アダプター (9V/500mA)



### DC3

¥1,890 (本体価格 ¥1,800)

コンパクト・エフェクター 3 台に電源を分配供給するコード (Ibanez AC アダプター推奨)



### DC5

¥2,310 (本体価格 ¥2,200)

コンパクト・エフェクター 5 台に電源を分配供給するコード (Ibanez AC アダプター推奨)

# TUNER

ギター/ベース/ウクレレ兼用  
クロマチック・クリップチューナー



### NEW MODEL PU2

¥2,100 (本体価格 ¥2,000)

• Tuning Range	A0 (27.50Hz) ~ C8 (4186Hz)
• Calibration	430 Hz - 450 Hz
• Power Supply	Lithium battery (CR2032) x 1 (3V)
• Dimension	30 (W) x 41 (H) x 57 (D) mm
• Weight	30g (including battery)

# TREMOLO ARM

Ultralite Tremolo Arm™

### NEW MODEL UTA20

¥7,350 (本体価格 ¥7,000)

- Carbon Graphite arm grip
- Light, durable & thicker arm grip for increased tremolo arm control.
- for Edge / Lo-Pro Edge / Edge-Pro / Edge-Zero / SynchroniZR / ZR-2 Tremolo Bridge



Edge-Zero / SynchroniZR / ZR-2 Tremolo Bridgeに  
ご使用の際は装着されている  
白いプッシュをすべて取り外してください





## COMPACT & LIGHT WEIGHT MOLDED CASE Cases

For Electric Guitar

**M5C**

¥16,800 (本体価格 ¥16,000)

for RG, RGA, RGD, S, SV, SA, JEM, UV, JS, AT, EGEN, APEX

\*楽器本体の厚みに合わせて使用する“振れ止め”が付属します。  
\*26.5"スケール以上の7弦モデルや8弦モデルは入りません。

For Electric Bass

**MB5C**

¥18,900 (本体価格 ¥18,000)

for SR, K5, GWB, GVB, PIB



M5C



MB5C

## Gig Bags



G.S.M.  
growing stars meeting

お気に入りのギターを持ち運ぶ。  
そのとき、バッグに求められるポイントとは何だろうか。

- 実用性?
- デザイン性?
- 収容力や耐久性?

G.S.M.がその問いに向けて出した答えこそ、  
“LEATHONE”ギグ・バッグ・シリーズ。

- 生活防水  
(レザー部:防水 / ファスナー部:撥水加工)
- 着脱可能なダブル・ストラップ  
(肩への負担を軽減するロング・サイズ・ショルダー・パッド付)
- スコア、エフェクターが収容可能な大容量ポケット  
(開閉はマグネット・ボタン)
- 手掛け部分は手にしっくり馴染む本体同素材の  
グリップ・ベルト仕様
- 変機をキズや破損から守るファー生地内装

For Electric Guitar

**LZG02**

¥16,590 (本体価格 ¥15,800)

ABK, CDB, DB

For Electric Bass

**LZB02**

¥18,690 (本体価格 ¥17,800)

ABK, CDB



Color : ABK



Color : CDB



Color : DB

## Power Pad Gig Bags

For Electric Guitar

**IGB621P**

¥7,875 (本体価格 ¥7,500)

BK, KH

- 25mm厚のハード・クッション(POWER PAD)を底面とサイドに使用
- Smart Pocket装備
- エフェクターやシールドなどをまとめて収納可能なボード付

\*変形モデルなど、一部の商品は収納できません。



Color : BK

Color : KH

For Electric Bass

**IBB621P**

¥7,875 (本体価格 ¥7,500)

BK, KH

- 25mm厚のハード・クッション(POWER PAD)を底面とサイドに使用
- Smart Pocket装備
- エフェクターやシールドなどをまとめて収納可能なボード付

\*変形モデルなど、一部の商品は収納できません。

For Electric Guitar

**IGB521**

¥5,250 (本体価格 ¥5,000)

BK

- 25mm厚のハード・クッション(POWER PAD)を底面とサイドに使用

\*変形モデルなど、一部の商品は収納できません。



IGB521

IBB521

For Electric Bass

**IBB521**

¥5,250 (本体価格 ¥5,000)

BK

- 25mm厚のハード・クッション(POWER PAD)を底面とサイドに使用

\*変形モデルなど、一部の商品は収納できません。

For Electric Bass

**IGB531**

¥5,250 (本体価格 ¥5,000)

CCT, CGR, CSD

- 25mm厚のハード・クッション(POWER PAD)を底面とサイドに使用

\*変形モデルなど、一部の商品は収納できません。



Color : CCT

Color : CGR

Color : CSD



# Ukulele BAG

## NEW MODEL IULC10 GR

¥3,150 (本体価格 ¥3,000)

コンサート・サイズ・ウクレレ用

## IULS10 BE

¥3,150 (本体価格 ¥3,000)

ソプラノ・サイズ・ウクレレ用



# Cable

## NEW MODEL SERIES PFC

アンフェノール・プラグを採用した、しなやかさと取り回しの良さが特徴の演奏者=Performer向けハイエンド・ケーブル。

- ① Amphenol Plug
- ② Velcro Tie included
- ③ Flexible PVC Jacket For Easy Handling
- ④ Diameter of the Cable : 6mm
- ⑤ Double Shield : Conductive PVC and Spiral Shielding Wires

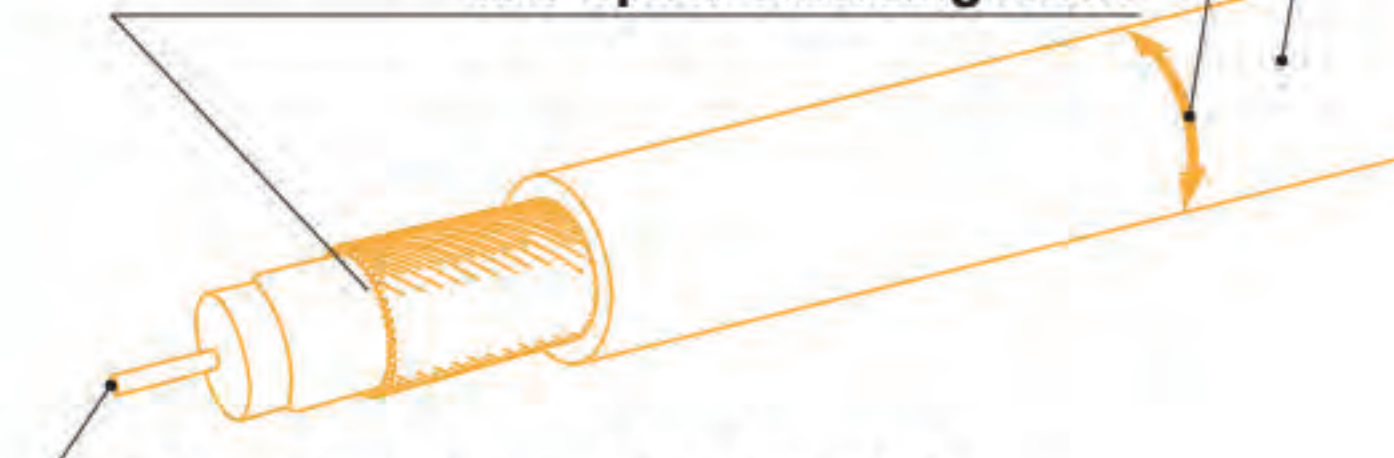

- ⑥ Oxygen Free Copper For Core Wire



- ① 堅牢でスタイリッシュなダイキャスト・ボディと、柔軟性に優れた樹脂ブッシュ・プラグ・エンドのAmphenol (アンフェノール) 社製プラグ
- ② 収納性に優れたベルクロ結束タイを装備
- ③ 当社従来素材を上回るしなやかさと取り回しの良いオリジナルPVCアウター・ジャケット
- ④ 必要な耐久性とストレスの無い重量感を両立させた6mm径サイズ
- ⑤ ノイズをシャット・アウトするPVC&スパイラル・シールド線による二重シールド構造
- ⑥ オーディオ・ケーブルのようなクリアでナチュラルな高音域を追求したOFC (無酸素銅) 芯線

Model	Configuration	Length	Price
PFC05LL	Right Angle & Right Angle	0.5ft / 15cm	¥3,465 (¥3,300)
PFC10	Straight & Straight	10ft / 3.05m	¥5,250 (¥5,000)
PFC10L	Straight & Right Angle	10ft / 3.05m	¥5,460 (¥5,200)
PFC20	Straight & Straight	20ft / 6.10m	¥6,090 (¥5,800)
PFC20L	Straight & Right Angle	20ft / 6.10m	¥6,300 (¥6,000)

Model	Configuration	Length	Price
STC05LL	Right Angle & Right Angle	0.5ft / 15cm	¥1,050 (¥1,000)
STC10	Straight & Straight	10ft / 3.05m	¥1,470 (¥1,400)
STC10L	Straight & Right Angle	10ft / 3.05m	¥1,680 (¥1,600)
STC20	Straight & Straight	20ft / 6.10m	¥2,100 (¥2,000)
STC20L	Straight & Right Angle	20ft / 6.10m	¥2,310 (¥2,200)

### Model Number System

Series

PFC: Series PFC  
STC: Series STC

P F C 0 5 L L

Plug Type

L: Straight - Right Angle  
LL: Right Angle - Right Angle  
none: Straight - Straight

Length

Length	05	10	20
0.5ft/15cm			
10ft/3.05m			
20ft/6.10m			

## SERIES STC

低価格ながらLow Noise、スタンダード・ギター・ケーブル。

- ① 耐久性に優れたオリジナル・プラグ形状
- ② 結束用オリジナル・ストラップ付属(10ft / 20ft)



# Straps

## GS1000T

¥1,050 (本体価格 ¥1,000)

BK, CA, DG, WH 最長145cm

プリントが施されたGS1000T。トライバルタトゥーでシャープな印象に。



## GS1800BP

¥1,890 (本体価格 ¥1,800)

BK

最長150cm

パレット・ブルーフ (防弾) 素材を使用したGS1800BP。軽量かつしなやかな触り心地で、スタンディング・プレイをしっかりサポートします。

## GS1600

¥1,680 (本体価格 ¥1,600)

最長165cm

体になじむ柔らかいビニール・レザーを使用したヴィンテージ・タイプのストラップ。ショルダー・パッドの裏側には滑り止め加工が施されています。



## GS1500

¥1,575 (本体価格 ¥1,500)

最長130cm

体になじむ柔らかいビニール・レザーを使用したヴィンテージ・タイプのストラップ。ショルダー・パッドの裏側には滑り止め加工が施されています。

# Stand



## ST101 Ibanez Electric/Acoustic Guitar and Bass Stand

¥2,415 (本体価格 ¥2,300)

エレクトリック・ギター / ベースを立掛けることもアコースティック・ギター / ベースを立掛けることも可能なコンパクト・スタンド。



## 839 TAMA Professional Grade Solid Guitar Stand

¥8,400 (本体価格 ¥8,000)

マイクスタンドと同じ構造を三脚部に採用することで、抜群の安定性を獲得したプロ・グレードのソリッド・ギター・スタンド。



## PT32 Pocket Titan - Solid Guitar Stand

¥1,995 (本体価格 ¥1,900)

BK, WH  
一般的なギター・バッグのポケットに収納可能な、Ibanezで最もコンパクトなスタンド。



# Picks

Actual size

様々なジャンル、プレイスタイルをカバーするIbanezピック・ラインナップ。  
プレイアビリティに大きく影響するピックのサイズや厚みはもちろんのこと、カラー・バリエーションもますます充実。  
また、プレイ中の汗によるピックの滑り落ちを防ぐGrip Wizardシリーズでは、ラバー・グリップとサンド・グリップ、  
そして新しくラインナップに加わったロゴグリップの3種類から選択可能。



## GripWizard Series / Sand Grip

すべて¥105 (本体価格 ¥100)

No.18



No.	Color	Size	Material
PA18XS	BK, WH	EXTRA HEAVY (1.2mm)	ポリアセタール
PA18HS	BK, WH	HEAVY (1.0mm)	ポリアセタール
PA18MS	BK, WH	MEDIUM (0.8mm)	ポリアセタール

No.16



No.	Color	Size	Material
PA16XS	BK, BL, RD, WH	EXTRA HEAVY (1.2mm)	ポリアセタール
PA16HS	BK, BL, RD, WH	HEAVY (1.0mm)	ポリアセタール
PA16MS	BK, BL, RD, WH	MEDIUM (0.8mm)	ポリアセタール

No.4



No.	Color	Size	Material
CE4HS	BK, BL, RD, SH, WH	HEAVY (1.0mm)	セルロイド
CE4MS	BK, BL, RD, SH, WH	MEDIUM (0.75mm)	セルロイド

## GripWizard Series / Ruber Grip

すべて¥105 (本体価格 ¥100)

No.18



No.	Color	Size	Material
PA18XR	BK, WH	EXTRA HEAVY (1.2mm)	ポリアセタール
PA18HR	BK, WH	HEAVY (1.0mm)	ポリアセタール
PA18MR	BK, WH	MEDIUM (0.8mm)	ポリアセタール

No.16



No.	Color	Size	Material
PA16XR	BK, BL, RD, WH	EXTRA HEAVY (1.2mm)	ポリアセタール
PA16HR	BK, BL, RD, WH	HEAVY (1.0mm)	ポリアセタール
PA16MR	BK, BL, RD, WH	MEDIUM (0.8mm)	ポリアセタール

No.4



No.	Color	Size	Material
CE4HR	BK, SH, WH	HEAVY (1.0mm)	セルロイド
CE4MR	BK, SH, WH	MEDIUM (0.75mm)	セルロイド

## Basic Color Series

すべて¥105 (本体価格 ¥100)

No.6



No.	Color	Size	Material
CE6H	BK, SH, WH	HEAVY (1.0mm)	セルロイド
CE6M	BK, SH, WH	MEDIUM (0.75mm)	セルロイド

No.20



No.	Color	Size	Material
CE20H	BK, SH	HEAVY (1.0mm)	セルロイド

## GripWizard Series / Logo Grip

すべて¥105 (本体価格 ¥100)

No.14



No.	Color	Size	Material
PA14HLG	BK, OR, RD, SB, WH	HEAVY (1.0mm)	ポリアセタール

## Signature Series

Steve Vai

1000SV-WHR ¥157 (本体価格 ¥150)  
その他 ¥105 (本体価格 ¥100)

No.	Color	Size	Material
1000SV-WHR	HEAVY (1.0mm)	ポリアセタール/ラバー・グリップ	
1000SV-MP	HEAVY (1.0mm)	ポリアセタール	
1000SV-BR	HEAVY (1.0mm)	ポリアセタール	
1000SV-GR	HEAVY (1.0mm)	ポリアセタール	

Paul Gilbert

2000PG ¥210 (本体価格 ¥200)  
その他 ¥105 (本体価格 ¥100)

No.	Color	Size	Material
2000PG	HEAVY (1.0mm)	セルロイド	
1000PG-PW	HEAVY (1.0mm)	セルロイド	
1000PG-CA	HEAVY (1.0mm)	PVC	
1000PG-JB	HEAVY (1.0mm)	セルロイド	
1000PG	HEAVY (1.0mm)	セルロイド	
1000PG-BK	HEAVY (1.0mm)	セルロイド	

The Offspring

すべて¥105 (本体価格 ¥100)



No.	Color	Size	Material
05-BL	HEAVY (1.0mm)	セルロイド	
05-RD	HEAVY (1.0mm)	PVC	
05-BK	HEAVY (1.0mm)	PVC	

George Benson

すべて¥105 (本体価格 ¥100)



No.	Color	Size	Material
1100GB	MEDIUM (0.75mm)	セルロイド	

John Scofield

すべて¥105 (本体価格 ¥100)



No.	Color	Size	Material
1000JS	HEAVY (1.0mm)	PVC	

Okuda Tamio

すべて¥105 (本体価格 ¥100)



No.	Color	Size	Material
TAMIO-E1	HEAVY (1.0mm)	セルロイド	
TAMIO-E2	MEDIUM (0.75mm)	セルロイド	
TAMIO-A2	MEDIUM (0.75mm)	セルロイド	





Francesco Artusato All Shall Perish	Karin Axelsson Sonic Syndicate	Robby Baca The Contortionist	Rob Balducci	Jackson Bengte (hed) planet earth	Adam Blackstone Eminem, Kanye West, Janet Jackson	Jake Bowen Periphery
Nili Brosh	John Browne Monuments	JB Brubaker August Burns Red	Stephen Bruner Suicidal Tendencies, Erykah Badu	Abel Camargo HIBRIA	Cat Casino Deathstars	Dino Cazares Fear Factory, Divine Heresy
Nick Conser Oceano	Marco Coti Zelati Lacuna Coil	James Davies The Blackout	Mark Davis Emmure	Isaac Delahaye Epica, MaYaN	Matt DeVries Fear Factory	Skinny Disco Deathstars
Fletcher Dragge Pennywise	Drop Sybreed	Martyn Evans Bleed From Within	Lee Foral After the Burial	Josh Gilbert As I Lay Dying	Chris Gomerson Glamour of the Kill	Craig Gowans Bleed From Within
Nate Grady Oh, Sleeper	Trent Hafdahl After the Burial	Daniel Haniß ESKIMO CALLBOY	Sami Hinkka Ensiferum	Nick Hipa As I Lay Dying	Dexter Holland The Offspring	Trond "Teeny" Holter Wig Wam
Jason Hook Five Finger Death Punch	Ricky Horror Motionless in White	Luke Hoskin Protest the Hero	Zach Huston Like Moths To Flames	Ihsahn Ihsahn, Emperor	Nightmare Industries Deathstars	Bernt "Flash" Jansen Wig Wam
Mark Jansen Epica, MaYaN	Pascal Jobin The Agonist	Jason Jones Oceano	Jari Kainulainen Devil's Train, Masterplan	Jesse Ketive Emmure	Mike Kingswood Glamour of the Kill	Daniel Klossek ESKIMO CALLBOY
Ryan Knight The Black Dahlia Murder	Kyle Koelsch Greeley Estates	Jukka Koskinen Wintersun, Northern, Amberian Dawn	Chase Kozlowski I, The Breather	Eric Krasno Soulive	Brad Lang Y&T	Brian Leppke Bleeding Through
Ari Levola One Morning Left	Benhur Lima HIBRIA	Petri Lindroos Ensiferum	Sean Long While She Sleeps	Justin Lowe After The Burial	Tony MacAlpine	Jari Mäenpää Wintersun
John 'Slo' Maggard Unearth	Teemu Mäntysaari Wintersun	Danny Marino The Agonist	Cameron Maynard The Contortionist	Aaran McKenzie While She Sleeps	Lewis Millen Yashin	Chris Miller You Me At Six



Larry Mitchell	Ben Monder	Monte Money Escape The Fate	James Monteith Tesseract	Kamal Musallam Kamal Musallam Group	Adam Nitti Solo Artist	Conor O'keefe Rise To Remain
Andre Olbrich Blind Guardian	Ben Orum Oblivion	Daniel Osborne Your Demise	Renato Osorio HIBRIA	Stu Paice Your Demise	Marek Pajak Vader	Pepe Reckless Love
Davie Provan Bleed From Within	Laki Ragazas Devil's Train	Brent Rambler August Burns Red	Josh Rand Stone Sour	Javier Reyes Animals as Leaders	Omar Rodriguez-Lopez Bosnian Rainbows	Patrick Rondat Patrick Rondat, Elegy
Chris Rubey The Devil Wears Prada	Jimmy Sampson Your Demise	Jessie Sanchez Bonded By Blood	V. Santura Triptykon	Pascal Schillo ESKIMO CALLBOY	Devin Shidaker Oceano	Roger Sjunnesson Sonic Syndicate
Terji Skibenæs Týr	Vanja Slajh Triptykon	Barry Stock Three Days Grace	Jesper Strömblad The Resistance	Muhammed Suiçmez Necrophagist	Fredrik Thordendal Meshuggah	Chris Tilley The Contortionist
Mike Tiner All Shall Perish	Markus Toivonen Ensiferum	J. Troy Musiq Soulchild, The Dream	Christian Vidal Therion	Angel Vivaldi	Tom G. Warrior Triptykon	Brian "Head" Welch
Mat Welsh While She Sleeps	Robert Westerholt Within Temptation	Jussi Wickström Turisas	Ryan Wombacher Bleeding Through	Sami Yli-Sirmiö Kreator, Barren Earth	Mark Young (hed) planet earth	西藤 ヒロノブ -GUITARS-
津本 幸司 -GUITARS-	野田 タロウ -GUITARS- BLACKBORDERS	平井 武士 -GUITARS-	HIRO Head Phones President	村鳥 靖 -GUITARS- MURATORIX	佑聖 -GUITARS- THE KIDDIE	零乃 -GUITARS- VIVID
JU-KEN -BASSES-	富倉 安生 -BASSES-	NARUMI -BASSES- Head Phone President	早川 岳晴 -BASSES-	依知川 伸一 -ELECTRONICS-	大山 純 -ELECTRONICS- STRAIGHTENER	黒柳 能生 -ELECTRONICS- SOPHIA
坂本 竜太 -ELECTRONICS-	Jean-Ken Johnny -ELECTRONICS- Man With A Mission	TAKE-C -ELECTRONICS- SHAKALABBITS	鳥超 啓介 -ELECTRONICS-	永井 敏己 -ELECTRONICS-	ホリエアツシ -ELECTRONICS- STRAIGHTENER	山田 章典 -ELECTRONICS-