



Fender
Custom Shop

1987 2017

30TH ANNIVERSARY

2017 Custom Guitar DESIGN GUIDE

Model Shown: Journeyman Relic 1964 Stratocaster
Gold Sparkle over Dakota Red, Built By John Cruz



Forward

A Fender Custom Shop instrument is extraordinary. You know it when you play one—it's definitely more than the sum of its parts. It's filled with intangible, electrifying elements that add a new dimension to your playing experience. It's as if the instrument itself is imbued with history, alive with the spirit of the place where it was built and the devotion of those who crafted it.

The Custom Shop is home to Fender's most skilled and talented builders. It's a bustling, noisy and creatively volcanic place that re-earns its nickname—the Dream Factory—every day. Custom Shop builders are completely dedicated to their art—part craftsman, part artist, part music fan and, more often than not, part mad scientist. They're the best at what they do, and they pour all of their

passion, hard-earned knowledge and skill into every instrument they build. It's no ordinary place, and the creations that come from it are no ordinary instruments. Welcome to the Fender Custom Shop.

For players who wish to create a completely custom instrument—anything from a humbucking pickup-equipped banjo to a custom-engraved aluminum-bodied Strat®—we offer Masterbuilt, a singular experience working one-on-one with one of our Master Builders. Custom-Built is for those prefer to start with one of our time-honored models and personalize the specifications to meet your specific needs. Use this guide to design your very own Masterbuilt or Custom-Built Fender guitar and make your dreams come true.

© 2017 Fender Musical Instruments Corporation. FENDER®, STRATOCASTER®, STRAT®, TELECASTER®, TELE®, PRECISION BASS®, P BASS®, JAZZ BASS®, J BASS®, ESQUIRE®, NOCASTER® and the distinctive headstock designs commonly found on Fender guitars are registered trademarks of FMIC. All rights reserved.

All other trademarks are the property of their respective owners.

All Fender Custom Shop instruments are expertly crafted according to exact order specifications and arrive free of defects. Those instruments not abiding by this policy will be repaired, modified or replaced by us at no cost to you. Consult your local retailer, distributor or the Custom Care™ website (customcare.fender.com) for details.

Fender Musical Instruments Corporation
 17600 North Perimeter Drive
 Scottsdale, AZ 85255-5440
 T: (480) 596-9690
 F: (480) 596-1384

fendercustomshop.com

All colors, features and specifications are subject to change without notice.

Photography by Mark Keraly ©FMIC



Contents

Masterbuilt	6
Master Builders	8
Custom-Built	12
Ordering Yours	14
Base Models	16
Stratocaster Models	17
Telecaster Models	18
Precision Bass Models	20
Jazz Bass Models	21
Offset Models	22
Aging Styles	24
Tone Wood Options	28
Body Wood	29
Neck Wood	30
Page with Wood	31
Color Options	32
Neck Shapes	36
Fret Wire	40
Pickup Option	42
Wiring Option	46
Hardware Options	54
Design Guide Order Form	59

Masterbuilt

In every art form there are those who have mastered their craft so thoroughly, through years of training and experience, their work routinely commands extra acclaim and admiration, not to mention outright awe. These astonishing artisans are the Master Builders of the Fender Custom Shop; a select group of the most talented builders recognized around the world for their matchless skill, limitless imagination and utter devotion to their art.

Crafting a guitar with a Custom Shop Master Builder is the ultimate artistic partnership—simply put, no idea is too crazy and no job too large or too small.

They'll walk you through everything—body design, neck shape, tonewoods, pickups, hardware and more—to give you the look, feel and sound that you're searching for. From start to finish the Master Builder will personally ensure that each guitar is built with the highest possible quality and to your exact specifications. Additionally, it's about more than just specifications, it's about making the instrument of your dreams a concrete reality.

MasterBuilders

Imagine the greatest artists in history gathered under one roof; Michelangelo, DaVinci, Picasso and Dali working next to each other, sharing pigments, knowledge and expertise. The Fender Custom Shop is exactly that, the world's most esteemed luthiers gathered together to create peerless instruments that are astounding works of art—the Master Builders. They are known

the world over for their skill and have built instruments for Jeff Beck, Ritchie Blackmore, Eric Clapton, Dick Dale, Mike Dirnt, Bob Dylan, Robben Ford, Buddy Guy, Merle Haggard, Reggie Hamilton, Mark Hoppus, John 5, Keith Richards, Sting and U2 ... just to name a few!



Dale Wilson

Dale Wilson arrived at Fender in 2003, joined the Custom Shop in 2005 and became a Master Builder in 2011. Building guitars has been a driving passion for the California native since childhood. "Ever since I can remember, I've always loved guitars," he said. "I didn't dream of being a rock star; I dreamt of building the ultimate guitar. I was equally enthralled with the guitars just as much as I was with the players."

Woodworking runs in the Wilson family, and the requisite Custom Shop zeal for outstanding craftsmanship has long been part of Dale's DNA. He did repair work and mods in a small guitar shop right out of high school in the late 1980s;

subsequently, he moved on to stints at Dobro and Rickenbacker before arriving at Fender, where he worked on Guild, Gretsch and Benedetto guitars before beginning his apprenticeship with various Custom Shop Master Builders.

He enjoys calling upon his extensive and varied experience as a craftsman to create highly distinctive guitars such as the Resophonic Thinline Telecaster®. Wilson also built five beautiful custom guitars for the January 2011 NAMM Show while still an apprentice and was asked to sign the back of the headstocks, garnering him his Master Builder status.



Paul Waller

Paul Waller is a Southern California native with woodworking and luthiery in his blood. He built his first guitar at age 14 in his high school woodshop, joined a cabinet shop right out of high school and, after a stint at a small Southern California guitar maker, enrolled at the acclaimed Roberto-Venn School of Luthiery in Phoenix, from which he graduated in spring of 2000.

Waller joined Fender in 2003. He spent two years working closely with master archtop craftsman Bob Benedetto, and became steeped in the many facets of building techniques from all the Custom Shop's Master Builders.

After an extensive seven-year apprenticeship, Waller became a Master Builder in 2010.

His Fender Custom Shop work includes bass guitars for U2's Adam Clayton, a custom Thinline Telecaster for U2 vocalist Bono, Telecaster guitars for the Rolling Stones' Keith Richards and co-work on a Stratocaster for fellow Stones guitarist Ronnie Wood, Stratocaster guitars for Buddy Guy, the Nile Rodgers "Hitmaker" Stratocaster, a custom double-neck Jazzmaster for Queens Of the Stone Age guitarist Troy Van Leeuwen and the George Harrison Tribute Rosewood Telecaster.



Jason Smith

A Custom Shop veteran and son of longtime Fender R&D legend Dan Smith, Jason Smith grew up on Fender — "It has always been in my family," he said, "And I was always extremely interested in everything my father did."

Born in Rochester, N.Y., and raised in California, Smith remembers meeting guitar greats from about age 5 on through his father's work with Fender—Eric Clapton, Yngwie Malmsteen, Jeff Beck and Robben Ford, to name only a few. He went to his first big rock concert at age six—Rush—and remembers going backstage with his dad and meeting Geddy Lee after the show. Before he was even in

his teens, Smith was going to see Pink Floyd, ZZ Top and many other major artists.

Rock music and Fender are part of Smith's DNA. He joined the Fender Custom Shop in 1995 and in 2006 completed a five-year apprenticeship under acclaimed Senior Master Builder John English. Among many diverse projects with English, Smith worked on a pair of double-neck Stratocaster guitars for Stone Temple Pilots guitarist Dean DeLeo. He has since crafted fine instruments for players and acts including John 5, Michael Landau, Flea, Josh Klinghoffer, Steve Harris, Reggie Hamilton, Linkin Park, Kenny Wayne Shepherd, Neon Trees and many others.



Yuriy Shishkov

From handcrafting many of his own woodworking tools to showcasing his world-class luthiery skills and custom inlay work, Yuriy Shishkov is truly a renaissance guitar builder. It was in the small confines of a root cellar in his hometown of Gomel in the former Soviet Union that Shishkov got his start building guitars for friends and colleagues.

When he arrived in the United States in 1990, Shishkov settled in the Chicago area and collaborated with a range of top artists,

including late shredder Dimebag Darrell of Pantera, Jimmy Page and Robert Plant of Led Zeppelin, Nuno Bettencourt of Extreme, Robin Zander of Cheap Trick and Paul Stanley of KISS. Shishkov joined the Fender Custom Shop's Master Builder team in 2000 and has crafted truly magnificent instruments featuring exquisite detail and inlay work.

Todd Krause

Todd Krause has built exquisitely crafted custom instruments for many of the world's greatest artists, including Jeff Beck, Eric Clapton, Bob Dylan, David Gilmour, Robbie Robertson, Kenny Wayne Shepherd, Robin Trower, Roger Waters and many others.

His guitar-building apprenticeship began in early 1981 at Jackson/Charvel guitars. Krause arrived at Fender in 1991 and steadily rose through several roles, including

one-off instrument builder, R&D model maker, and woodworking machinist. He became a Custom Shop Master Builder in 1997 and has created countless distinctive instruments, all of which embody his personal design philosophy: "Form and function are the biggest part of it," he said. "It's about the way an instrument sounds and feels. It has to look cool, and it has to compel you to play."



Dennis Galuszka

Like Fender itself, Dennis Galuszka is a Southern California native. Combining his dual passions for music and woodworking, he began building high-end acoustic guitars during his 13 years as a cabinetmaker. As a working drummer, it was a 1999 audition with one of the Fender Master Builders that led to a job interview and a new kind of steady gig—as an apprentice at the Fender Custom Shop.

After only eight months there, Galuszka was promoted to Master Builder. He has since built finely crafted instruments for influential

players including Paul McCartney, Andy Summers, Johnny Marr, Patrick Stump, Mike Dirnt, Sting and many others. He has lent his expertise to a number of truly distinctive instruments, including double-neck guitars and unusual takes on classic Fender designs along with several artist models.

"It's all about the feel and sound of an instrument," Galuszka said. "Those things are number one with me, above everything else."



Greg Fessler

Greg Fessler came to the Fender Custom Shop in 1990, working his way up through the ranks as an apprentice. He assisted with the Robben Ford signature line of guitars, eventually becoming the sole builder of those instruments and, later, Ford's personal builder. Fessler has built one-off Stratocaster and Telecaster models for a host of players, including Joe Bonnamasa, Jeff Healey, Hank Marvin, John Mayer, Rhonda Smith, Neil

Schon and Pete Wentz, to name a few.

Fessler's remarkable abilities as a Master Builder have earned him accolades from many Fender artists and from discerning customers worldwide. His meticulous attention to detail is exemplified in every instrument he creates, each of which is a perfect example of the intense commitment it takes to earn the title of Master Builder.



John Cruz

John Cruz came to Fender in 1987, joined the Custom Shop in 1993 and became a Master Builder in 2003. Being a guitarist and understanding what a great guitar should look, feel and sound like has always been a top priority for him. Custom guitars are his passion, and he is the man behind several famous Custom Shop instruments, including the replica of Stevie Ray Vaughan's famous "Number One" Stratocaster guitar, the Jeff Beck Esquire Relic (as used with the Yardbirds), the replica of Yngwie Malmsteen's famous "Duck" Stratocaster, the John Mayer Limited Edition Black 1 Stratocaster and the

famed Limited Edition Gary Moore 1961 Fiesta Red Stratocaster as well as countless others.

John has built fantastic guitars for players such as Doug Aldrich of Dio and Whitesnake, Dave Amato and Bruce Hall of REO Speedwagon, Mick Mars of Mötley Crüe, Richie Sambora of Bon Jovi, Bono of U2, Duff McKagan of Guns N' Roses and Velvet Revolver, Ike Turner, Brad Whitford of Aerosmith, Jeff Beck, John Mayer and countless others. Furthermore, his meticulous work was essential to the initial Custom Shop Relic guitars and basses and he initiated the Custom Shop's quality assurance program.



Custom-Built



Your dreams are what make the Fender Custom Shop the reality that it is today. From its inception in 1987, the Custom Shop has grown from two builders to today's more than 50 artisans—a veteran band of builders, each a specialist dedicated to their own area of expertise—working together to build your ideal Fender to your exact specifications. From neck shaping and fretwork to finishing and aging—every step of creation—each Custom Shop craftsman brings years of hard-earned skill and dedication to bear on your custom-built guitar with one goal in mind—to create an instrument and playing experience that can only come from the Fender Custom Shop.

A Fender Custom-Built guitar lets you define your ideal instrument. Begin with one of our base models and choose from our vast selection of options to customize it as little or as much as you want to meet your personal needs, aesthetic taste and playing style.

Whatever shape your dream may be, our luthiers stand ready to craft an instrument that will unlock your utmost creativity and self-expression. Their passion is bringing your dreams to reality, to create the ultimate instrument—one personally customized exclusively for you.

Ordering Yours

Is there a special Fender instrument that you have been dreaming of your whole life? We have some good news for you! The Fender Custom Shop can take your dreams and shape them into a tonal reality. The process is simple:

1. Choose your build level (Masterbuilt or Custom-built)
2. Choose a base model (list begins on pg.16)
3. Choose an aging package
4. Choose your custom options from our extensive menu of offerings
5. Use the “additional notes” section if your desired options are not listed
6. Take this completed design guide to a Custom Shop Showcase Dealer which you can find at www.fendercustomshop.com/dealers/

HOW TO USE THIS GUIDE

- 1 SELECT A **BUILD LEVEL**
- 2 SELECT A **CUSTOM SHOP BASE MODEL**
- 3 SELECT AN **AGING PACKAGE**
- 4 SELECT YOUR **OPTIONS**
- 5 **SUBMIT YOUR ORDER**

SELECT A BaseModel



Model Shown: 2017 Artisan Tamo Ash Stratocaster

STRATOCASTER BASE MODELS



Shown in 2-Color Sunburst

1955 STRATOCASTER

BODY WOOD	Ash
BODY FINISH	Nitrocellulose Lacquer
NECK WOOD	Maple
NECK SHAPE	'55 "U"
FINGERBOARD	1-piece Maple
RADIUS	7.25"
FRET SIZE	Vintage
FACE DOTS	Black Micarta - Wide Spacing
NUT	Micarta
TUNERS	Fender Gotoh Vintage
HARDWARE	Nickel / Chrome
BRIDGE	Vintage Synchronized Tremolo
PICKGUARD	1-ply White
WIRING	Vintage Strat w/ 3-way Switch
PICKUPS	FCS 1950s Strat



Shown in White Blonde

1956 STRATOCASTER

BODY WOOD	Alder
BODY FINISH	Nitrocellulose Lacquer
NECK WOOD	Maple
NECK SHAPE	10/56 "V"
FINGERBOARD	1-piece Maple
RADIUS	7.25"
FRET SIZE	Vintage
FACE DOTS	Black Micarta - Wide Spacing
NUT	Micarta
TUNERS	Fender Gotoh Vintage
HARDWARE	Nickel / Chrome
BRIDGE	Vintage Synchronized Tremolo
PICKGUARD	1-ply White
WIRING	Vintage Strat w/ 3-way Switch
PICKUPS	FCS 1950s Strat



Shown in Dakota Red

1960 STRATOCASTER

BODY WOOD	Alder
BODY FINISH	Nitrocellulose Lacquer
NECK WOOD	Maple
NECK SHAPE	'60s Oval "C"
FINGERBOARD	Slab Rosewood
RADIUS	7.25"
FRET SIZE	Vintage
FACE DOTS	Clay - Wide Spacing
NUT	Micarta
TUNERS	Fender Gotoh Vintage
HARDWARE	Nickel / Chrome
BRIDGE	Vintage Synchronized Tremolo
PICKGUARD	3-ply White
WIRING	Vintage Strat w/ 3-way Switch
PICKUPS	FCS 1960s Strat



Shown in 3-Color Sunburst

1963 STRATOCASTER

BODY WOOD	Alder
BODY FINISH	Nitrocellulose Lacquer
NECK WOOD	Maple
NECK SHAPE	'60s Oval "C"
FINGERBOARD	Round-Lam Rosewood
RADIUS	7.25"
FRET SIZE	Vintage
FACE DOTS	Clay - Narrow Spacing
NUT	Micarta
TUNERS	Fender Gotoh Vintage
HARDWARE	Nickel / Chrome
BRIDGE	Vintage Synchronized Tremolo
PICKGUARD	3-ply White
WIRING	Vintage Strat w/ 3-way Switch
PICKUPS	FCS 1960s Strat



Shown in Aztec Gold

1965 STRATOCASTER

- BODY WOOD | Alder
- BODY FINISH | Nitrocellulose Lacquer
- NECK WOOD | Maple
- NECK SHAPE | '65 "C"
- FINGERBOARD | Round-Lam Rosewood
- RADIUS | 7.25"
- FRET SIZE | Vintage
- FACE DOTS | Pearl – Narrow Spacing
- NUT | Micarta
- TUNERS | Fender Gotoh Vintage
- HARDWARE | Nickel / Chrome
- BRIDGE | Vintage Synchronized Tremolo
- PICKGUARD | 3-ply White
- WIRING | Vintage Strat w/ 3-way Switch
- PICKUPS | FCS 1965 Strat



Shown in Sonic Blue

1969 STRATOCASTER

- BODY WOOD | Alder
- BODY FINISH | Nitrocellulose Lacquer
- NECK WOOD | Maple – Urethane Finish
- NECK SHAPE | '69 "C"
- FINGERBOARD | Round-Lam Rosewood or Maple
- RADIUS | 7.25"
- FRET SIZE | Vintage
- FACE DOTS | Pearl White or Black
- NUT | Micarta
- TUNERS | Schaller "F"
- HARDWARE | Nickel / Chrome
- BRIDGE | Vintage Synchronized Tremolo
- PICKGUARD | 3-ply White
- WIRING | Vintage Strat w/ 3-way Switch
- PICKUPS | FCS 1969 Strat



Shown in White Blonde

1960 TELECASTER

- BODY WOOD | Alder
- BODY FINISH | Nitrocellulose Lacquer
- NECK WOOD | Maple
- NECK SHAPE | '60s Oval "C"
- FINGERBOARD | Slab Rosewood
- RADIUS | 7.25"
- FRET SIZE | Vintage
- FACE DOTS | Clay – Narrow Spacing
- NUT | Micarta
- TUNERS | Fender Gotoh Vintage
- HARDWARE | Nickel / Chrome
- BRIDGE | Vintage with Threaded Saddles
- PICKGUARD | 3-ply White
- WIRING | Vintage Tele w/ 3-way Switch
- PICKUPS | FCS '60 - '63 Telecaster



Shown in Black

1960 TELECASTER CUSTOM

- BODY WOOD | Double-bound Alder
- BODY FINISH | Nitrocellulose Lacquer
- NECK WOOD | Maple
- NECK SHAPE | '60s Oval "C"
- FINGERBOARD | Slab Rosewood
- RADIUS | 7.25"
- FRET SIZE | Vintage
- FACE DOTS | Clay
- NUT | Micarta
- TUNERS | Fender Gotoh Vintage
- HARDWARE | Nickel / Chrome
- BRIDGE | Vintage with Threaded Saddles
- PICKGUARD | 3-ply White
- WIRING | Vintage Tele w/ 3-way Switch
- PICKUPS | FCS '60 - '63 Telecaster

TELECASTER BASE MODELS



Shown in Honey Blonde

1951 NOCASTER

- BODY WOOD | Ash
- BODY FINISH | Nitrocellulose Lacquer
- NECK WOOD | Maple
- NECK SHAPE | Nocaster "U"
- FINGERBOARD | 1-piece Maple
- RADIUS | 7.25"
- FRET SIZE | Vintage
- FACE DOTS | Black Micarta – Narrow Spacing
- NUT | Micarta
- TUNERS | Fender Gotoh Vintage
- HARDWARE | Nickel / Chrome
- BRIDGE | Vintage with Brass Saddles
- PICKGUARD | 1-ply Black
- WIRING | Vintage Tele w/ 3-way Switch
- PICKUPS | FCS 1951 Nocaster



Shown in Lake Placid Blue

1963 TELECASTER

- BODY WOOD | Alder
- BODY FINISH | Nitrocellulose Lacquer
- NECK WOOD | Maple
- NECK SHAPE | '60s Oval "C"
- FINGERBOARD | Round-Lam Rosewood
- RADIUS | 7.25"
- FRET SIZE | Vintage
- FACE DOTS | Clay
- NUT | Micarta
- TUNERS | Fender Gotoh Vintage
- HARDWARE | Nickel / Chrome
- BRIDGE | Vintage with Threaded Saddles
- PICKGUARD | 3-ply White
- WIRING | Vintage Tele w/ 3-way Switch
- PICKUPS | FCS '60 - '63 Telecaster



Shown in 2-Color Sunburst

1952 TELECASTER

- BODY WOOD | Ash
- BODY FINISH | Nitrocellulose Lacquer
- NECK WOOD | Maple
- NECK SHAPE | '52 "U"
- FINGERBOARD | 1-piece Maple
- RADIUS | 7.25"
- FRET SIZE | Vintage
- FACE DOTS | Black Micarta – Wide Spacing
- NUT | Micarta
- TUNERS | Fender Gotoh Vintage
- HARDWARE | Nickel / Chrome
- BRIDGE | Vintage with Brass Saddles
- PICKGUARD | 1-ply Black
- WIRING | Vintage Tele w/ 3-way Switch
- PICKUPS | FCS 1951 Nocaster



Shown in Candy Apple Red

1967 TELECASTER

- BODY WOOD | Alder
- BODY FINISH | Nitrocellulose Lacquer
- NECK WOOD | Maple
- NECK SHAPE | '60s Oval "C"
- FINGERBOARD | Rosewood or Maple
- RADIUS | 7.25"
- FRET SIZE | Vintage
- FACE DOTS | Pearl White or Black Micarta
- NUT | Micarta
- TUNERS | Schaller "F"
- HARDWARE | Nickel / Chrome
- BRIDGE | Vintage with Threaded Saddles
- PICKGUARD | 3-ply White
- WIRING | Vintage Tele w/ 3-way Switch
- PICKUPS | FCS 1967 Telecaster



Shown in 3-Color Sunburst

1959 ESQUIRE

- BODY WOOD | Ash
- BODY FINISH | Nitrocellulose Lacquer
- NECK WOOD | Maple
- NECK SHAPE | '59 "C"
- FINGERBOARD | 1-piece Maple
- RADIUS | 7.25"
- FRET SIZE | Vintage
- FACE DOTS | Micarta Black - Wide Spacing
- NUT | Micarta
- TUNERS | Fender Gotoh Vintage
- HARDWARE | Nickel / Chrome
- BRIDGE | Vintage '59 w/Threaded
- PICKGUARD | 1-ply Parchment
- WIRING | Vintage Esquire 3-way Switch
- PICKUPS | FCS Vintage Telecaster



Shown in 2-Color Sunburst

1950'S THINLINE TELECASTER

- BODY WOOD | Ash
- BODY FINISH | Nitrocellulose Lacquer
- NECK WOOD | Maple
- NECK SHAPE | Nocaster "U"
- FINGERBOARD | 1-piece Maple
- RADIUS | 7.25"
- FRET SIZE | Vintage
- FACE DOTS | Clay - Narrow Spacing
- NUT | Micarta
- TUNERS | Fender Gotoh Vintage
- HARDWARE | Nickel / Chrome
- BRIDGE | Vintage with Brass Saddles
- PICKGUARD | 1-ply Black
- WIRING | Vintage Tele w/ 3-way Switch
- PICKUPS | FCS 1951 Nocaster

PRECISION BASS BASE MODELS



Shown in Vintage Blonde

1955 PRECISION BASS

- BODY WOOD | Ash
- BODY FINISH | Nitrocellulose Lacquer
- NECK WOOD | Quartersawn Maple
- NECK SHAPE | '55 PBass Soft "V"
- FINGERBOARD | 1-piece Maple
- RADIUS | 7.25"
- FRET SIZE | Vintage
- FACE DOTS | Clay
- NUT | Micarta
- TUNERS | Fender Gotoh Reverse
- HARDWARE | Nickel / Chrome
- BRIDGE | Vintage
- PICKGUARD | 1-ply White
- WIRING | Vintage Precision Bass
- PICKUPS | FCS 1950s Precision Bass



Shown in Black

1959 PRECISION BASS

- BODY WOOD | Alder
- BODY FINISH | Nitrocellulose Lacquer
- NECK WOOD | Quartersawn Maple
- NECK SHAPE | '60s PBass Oval "C"
- FINGERBOARD | Maple
- RADIUS | 7.25"
- FRET SIZE | Vintage
- FACE DOTS | Clay
- NUT | Micarta
- TUNERS | Fender Gotoh Reverse
- HARDWARE | Nickel / Chrome
- BRIDGE | Vintage
- PICKGUARD | Gold Anodized
- WIRING | Vintage Precision Bass
- PICKUPS | FCS '59 - '62 Bass



Shown in 3-Color Sunburst

1960 PRECISION BASS

- BODY WOOD | Ash
- BODY FINISH | Nitrocellulose Lacquer
- NECK WOOD | Maple
- NECK SHAPE | '60s PBass Oval "C"
- FINGERBOARD | Rosewood
- RADIUS | 7.25"
- FRET SIZE | Vintage
- FACE DOTS | Clay
- NUT | Micarta
- TUNERS | Fender Gotoh Reverse
- HARDWARE | Nickel / Chrome
- BRIDGE | Vintage
- PICKGUARD | 4-ply Tortoise Shell
- WIRING | Vintage Precision Bass
- PICKUPS | FCS '59 - '62 Bass

JAZZ BASS BASE MODEL



Shown in Sonic Blue

1964 JAZZ BASS

- BODY WOOD | Alder
- BODY FINISH | Nitrocellulose Lacquer
- NECK WOOD | Maple
- NECK SHAPE | '60 "U"
- FINGERBOARD | Round-Lam Rosewood
- RADIUS | 7.25"
- FRET SIZE | Vintage
- FACE DOTS | Clay
- NUT | Micarta
- TUNERS | Fender Gotoh Reverse
- HARDWARE | Nickel / Chrome
- BRIDGE | Vintage
- PICKGUARD | 4-ply Tortoise Shell
- WIRING | Vintage Jazz Bass
- PICKUPS | FCS Vintage Jazz Bass

OFFSET BASE MODELS



Shown in Surf Green

1962 JAZZMASTER

- BODY WOOD | Alder
- BODY FINISH | Nitrocellulose Lacquer
- NECK WOOD | Maple
- NECK SHAPE | Jazzmaster "C"
- FINGERBOARD | Slab Rosewood
- RADIUS | 7.25"
- FRET SIZE | Vintage
- FACE DOTS | Clay
- NUT | Micarta
- TUNERS | Fender Gotoh Vintage
- HARDWARE | Nickel / Chrome
- BRIDGE | Vintage Jaguar/Jazzmaster
- PICKGUARD | 4-ply Tortoise Shell
- WIRING | Vintage Jazzmaster
- PICKUPS | FCS Jazzmaster



Shown in Fiesta Red

1962 JAGUAR

- BODY WOOD | Alder
- BODY FINISH | Nitrocellulose Lacquer
- NECK WOOD | Maple
- NECK SHAPE | Jaguar "C"
- FINGERBOARD | Slab Rosewood
- RADIUS | 7.25"
- FRET SIZE | Vintage
- FACE DOTS | Clay
- NUT | Micarta
- TUNERS | Fender Gotoh Vintage
- HARDWARE | Nickel / Chrome
- BRIDGE | Vintage Jaguar/Jazzmaster
- PICKGUARD | 4-ply Tortoise Shell
- WIRING | Vintage Jaguar
- PICKUPS | FCS Jaguar

OFFSET BASE MODELS



Shown in 3-Color Sunburst

BASS VI

BODY WOOD	Alder
BODY FINISH	Nitrocellulose Lacquer
NECK WOOD	Quartersawn Maple
NECK SHAPE	"C"
FINGERBOARD	Slab Rosewood
RADIUS	7.25"
FRET SIZE	Vintage
FACE DOTS	Clay
NUT	Micarta
TUNERS	Fender Gotoh Vintage
HARDWARE	Nickel / Chrome
BRIDGE	Vintage Jaguar
PICKGUARD	4-ply Tortoise Shell
WIRING	Vintage Bass VI
PICKUPS	FCS Jaguar



SELECT AN Aging Style

Every guitar tells a story, one that is most readily apparent in the finish. Six different levels of aging let you select the exact appearance of your Dream Shop instrument.

From a pristine untouched finish that could have leapt from a '50s time capsule to the heavily-worn, weathered appearance of a trusty "road dog" companion guitar, our artful Custom Shop luthiers are masters of the craft of aging an instrument.

NEW OLD STOCK (NOS)

Models from the past that have survived to the present day looking brand new. An all-lacquer finish that looks as if it hasn't aged at all—as if you went back in time and bought it.

1956 Stratocaster in White Blonde



CLOSET CLASSIC

No real playing wear, but more subtle indications of the ages, such as a finish that has lost its sheen, mild discoloration of plastic parts, metal hardware showing slight oxidation, "mild" finish checking and minor surface scratches on the body and headstock.

Limited Edition 1958 Jazzmaster in 2-Color Sunburst



LUSH CLOSET CLASSIC®

Well taken care of and religiously polished throughout the years. The owner of this guitar took pride in keeping it clean and shiny. Over time the finish started showing age and like a fine wine it evolved into something complex and refined. Moderate finish checking, oxidation of hardware, and mild discoloration of parts give this finish its distinct look and feel.

Post-Modern Telecaster in Faded Firemist Silver



JOURNEYMAN RELIC®

Handed down or changed hands through the years but mostly played around the house, with the occasional jam session or weekend gig. Has been well taken care of over the years but has moderate wear, finish checking, and some “friendly” down-to-the-wood nicks and dings, dullish hardware, and moderate wear—a very lucky find.



1959 Jazzmaster in Aged Fiesta Red

RELIC®

The Authentic worn-in wear of a guitar that has experienced many years of regular use in clubs and bars. Marks that tell a story, finish checking all over the body; scars, dings and dents from bridge to headstock.



1960 Stratocaster in Aged Daphne Blue

HEAVY RELIC®

The heaviest of the relic treatments, designed to evoke decades of the most punishing play and touring. From serious dinged and wear to intensely discolored hardware and finish, the true battle-hardened workhorse.



1953 Telecaster in Butterscotch Blonde



Model Shown: Heavy Relic 1958 Stratocaster
Aged Sonic Blue Over 3-Color Sunburst, Built By Dale Wilson

SELECT A ToneWoodOption

BODY WOOD OPTIONS



ALDER

A fantastic tone wood long used by Fender for its electric guitar bodies, alder is noted for bright, balanced and resonant tone with pronounced upper midrange, excellent sustain and sharp attack. It also features large, swirling grain patterns.



ASH

Strong and dense, ash is a longtime Fender classic for electric instrument bodies. Notably resonant and sweet sounding, it's characterized by well-defined midrange and strong low end.



MAHOGANY

A dense, dark tone wood that yields warm tone and midrange bite, mahogany is a great option that adds a unique and complex sonic and visual twist to your build.



ROASTED ASH BODY

Strong and ultra-stable, a roasted ash body is a thing of beauty. Not only does the roasting process accentuate the figuring of the wood, it also crystallizes the sap, giving it the sound of old wood.



ROASTED ALDER

The roasting process will darken the wood while keeping it very stable and durable. As with a slab of wood that has dried over the years, the properties change slightly and add to the richness and depth of tone.

QUILT/FLAME TOP OPTIONS



QUILT MAPLE TOP

A beautifully figured wood, quilt maple works especially well with transparent and natural finishes that allow the flowing grain to show through.



AA FLAME MAPLE TOP

AA flame maple features tiger-like striping in the wood grain. Many believe that this is caused by the tree swaying in the wind, the minerals in the ground and other ephemeral variables. We aren't positive about that, but we do know it provides a strikingly beautiful look to any instrument neck or body.



AAA FLAME MAPLE TOP

AAA flame maple sorts a more intense concentration of figuring than AA Flame. The bold stripes are always a beautiful touch in natural and transparent finishes.



NECK WOOD OPTIONS

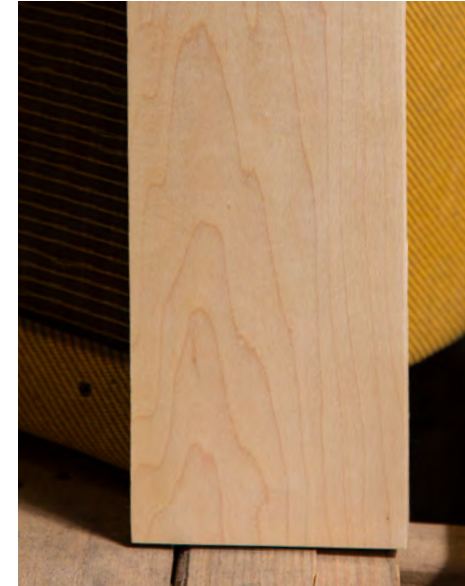

MAPLE NECK

Light in color, with a bright, chimey tone, maple is favorite amongst many Fender players for its look, feel and tone.



FLAME NECK

With its strong, vibrant figure, flame maple is one of our favorite ways to liven up the look of a maple neck.



BIRDSEYE MAPLE

Small round figuring in the wood which produces small "birdseye" markings. Used on many Custom Shop guitars, a birdseye maple neck will add a unique and striking look to your guitar.



ROASTED MAPLE NECK

Roasting your maple neck will not only make the wood darker and pop the grain, it also warms up your tone. The roasting process makes the wood stable and more resonant and looks amazing.



ROSEWOOD NECK

Darker in color and warmer in tone than maple, rosewood can be specially sorted for a darker color. In 1959, all Fenders were outfitted with rosewood fingerboards, which was a significant departure from the look and tone of the previous maple boards.

SELECT A ColorOption



00 | 3 COLOR SUNBURST



01 | WHITE BLONDE



02 | LAKE PLACID BLUE



03 | 2 COLOR SUNBURST



04 | DAPHNE BLUE



05 | OLYMPIC WHITE



06 | BLACK



07 | VINTAGE BLONDE



08 | OCEAN TURQUOISE



09 | CANDY APPLE RED

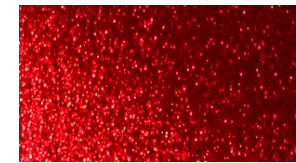

12 | RED SPARKLE



13 | BLUE SPARKLE



15 | HOT ROD RED



17 | SILVER SPARKLE



18 | GOLD SPARKLE

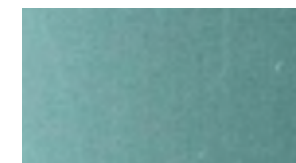

19 | SAGE GREEN METALLIC



20 | AMBER



21 | NATURAL



22 | SUNSET ORANGE TRANS



23 | PEARL WHITE



24 | INCA SILVER



25 | CHROME RED



26 | VIOLET



27 | SAPPHIRE BLUE TRANS



28 | CRIMSON BURST



29 | BLUE AGAVE

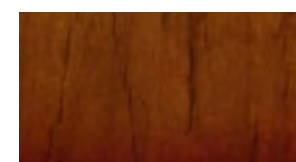

30 | CHERRY SUNBURST



31 | AGED CHERRY SUNBURST



32 | BROWN SUNBURST

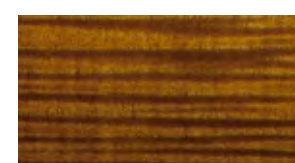

33 | VIOLIN BURST



34 | AGED NATURAL



36 | BLUE BURST



37 | ANTIQUE BURST



38 | CRIMSON TRANS



39 | EBONY TRANS



40 | FIESTA RED

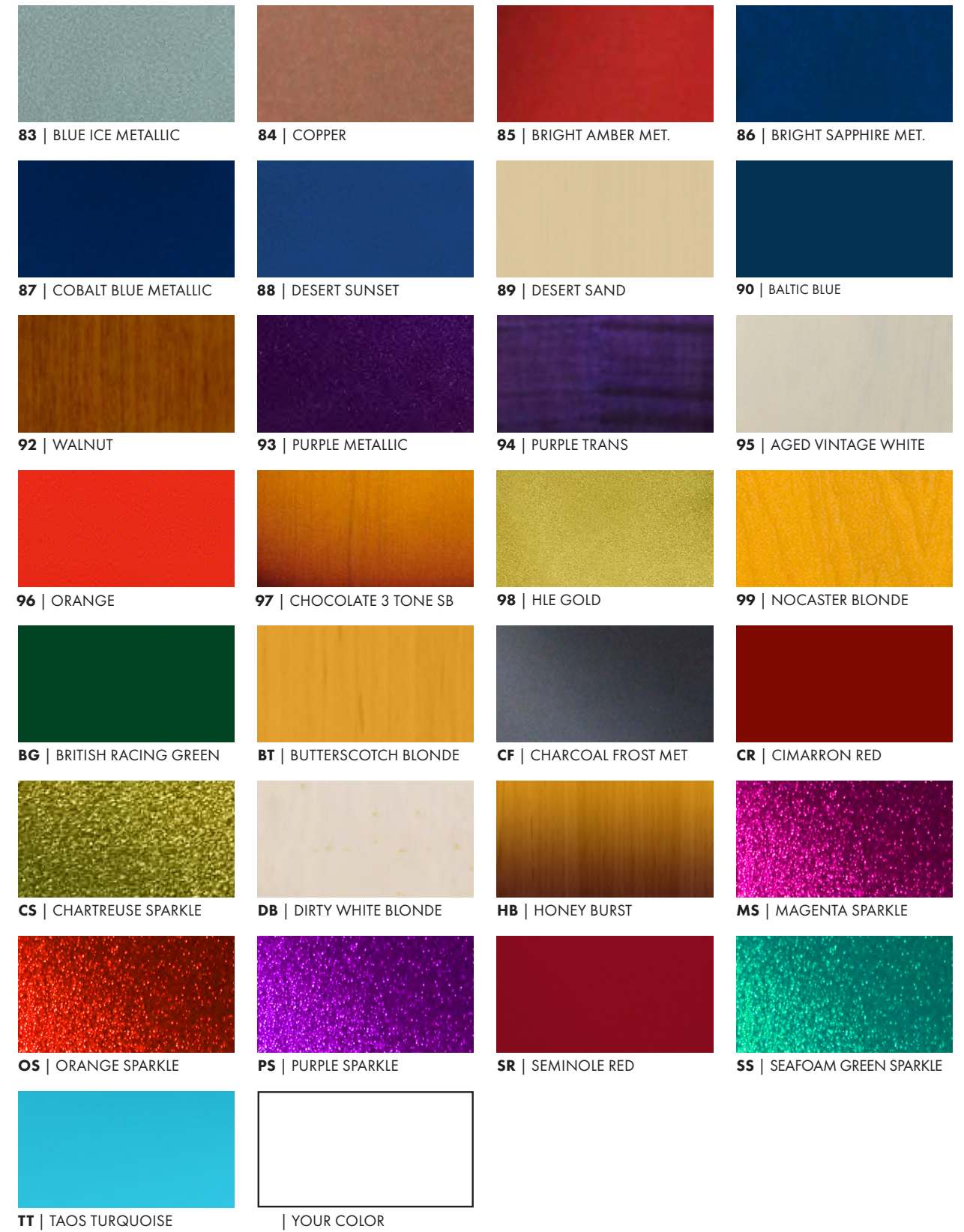

SELECT A NeckShape

Everybody plays differently, and the “right” neck shape can go a long way to making any guitar feel like “home”. We offer a number of classic profiles from Fender’s storied history—all artfully shaped by hand. If you have a special neck shape in mind, a Custom Shop Master Builder can craft any neck you desire.

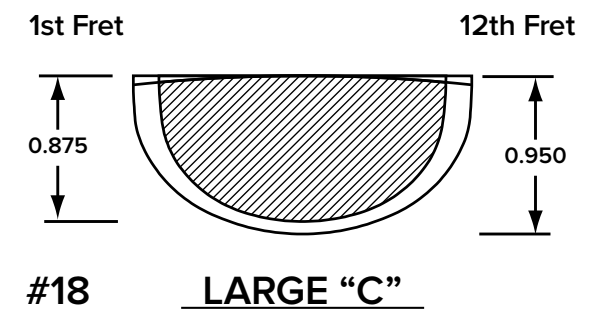
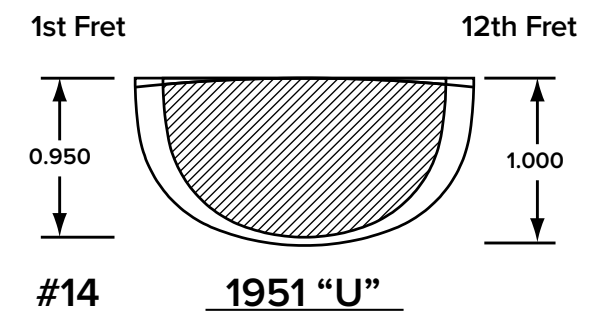
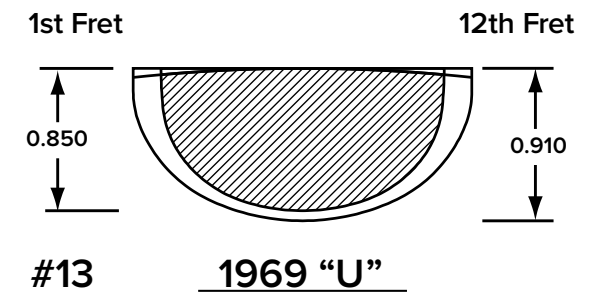
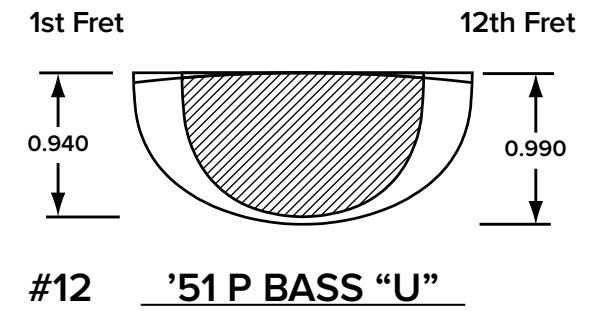
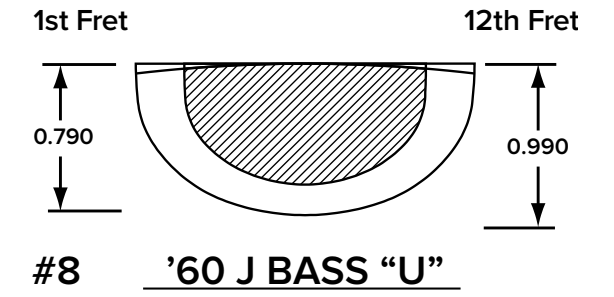
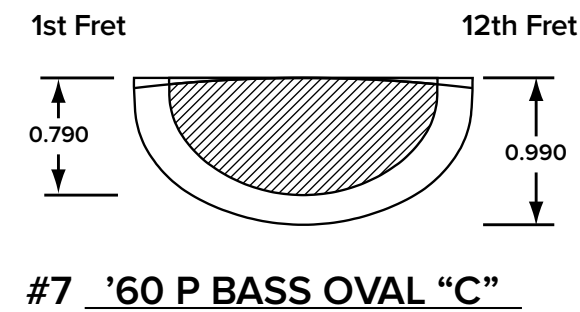
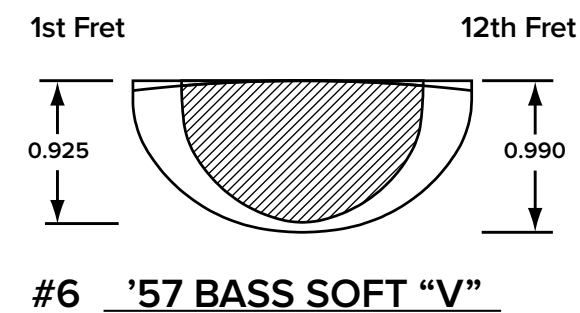
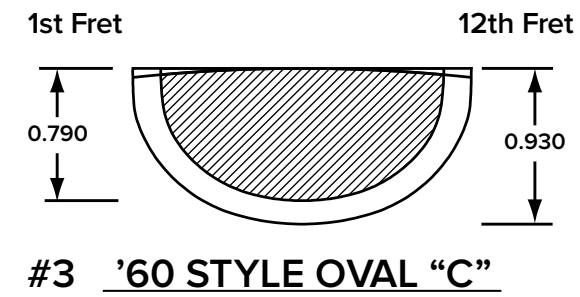
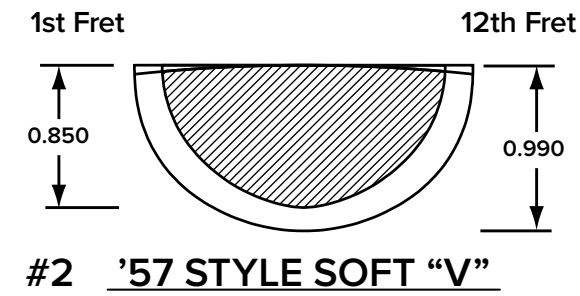
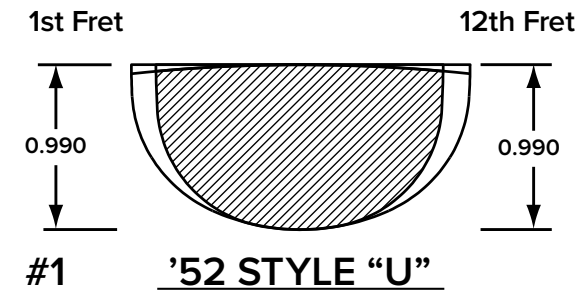

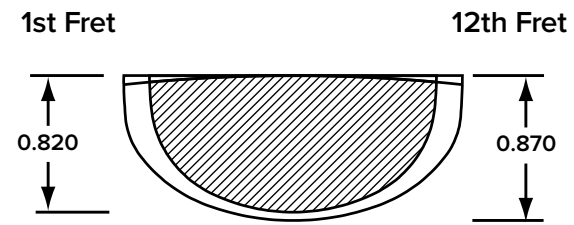

#19 MODERN "C"

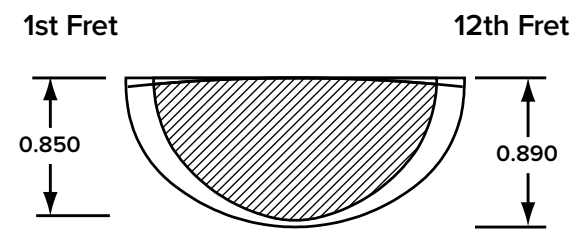

#20 MODERN "V"

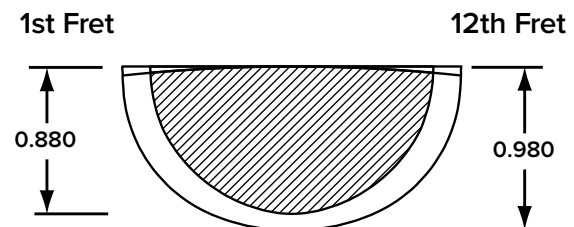

#23 10/56 "V"

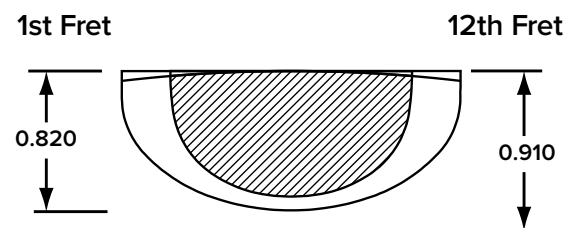

#26 CC JAZZ BASS
4 STRING "C"

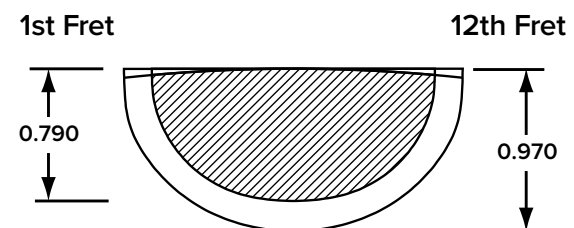

#28 '59 "C"

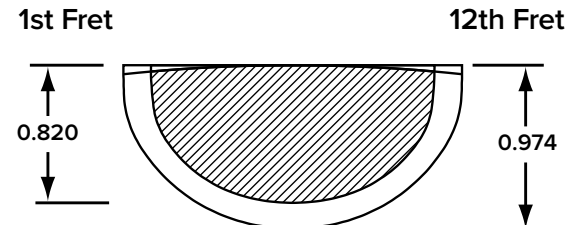

#29 '65 STRAT "C"

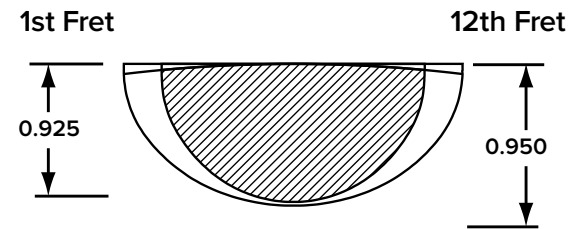

#30 '55 P BASS SOFT "V"

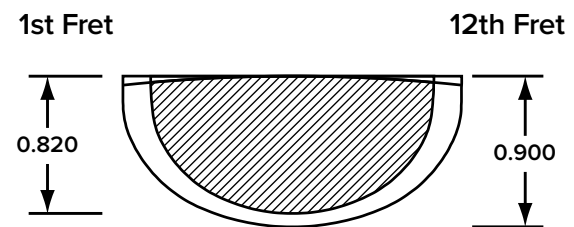

#36 JAGUAR /
JAZZMASTER "C"

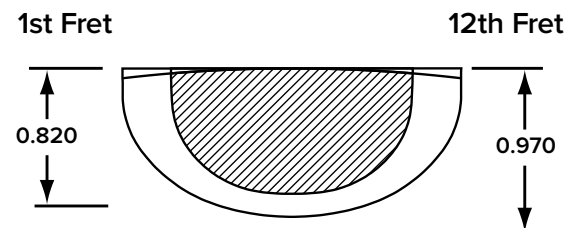

#40 '75 JAZZ BASS

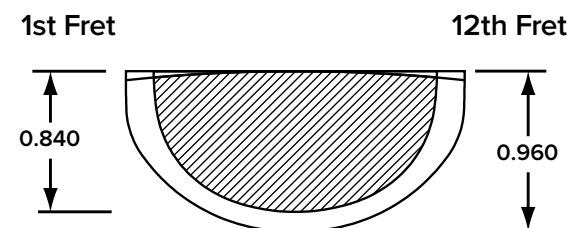

#51 '66 STRAT OVAL "C"

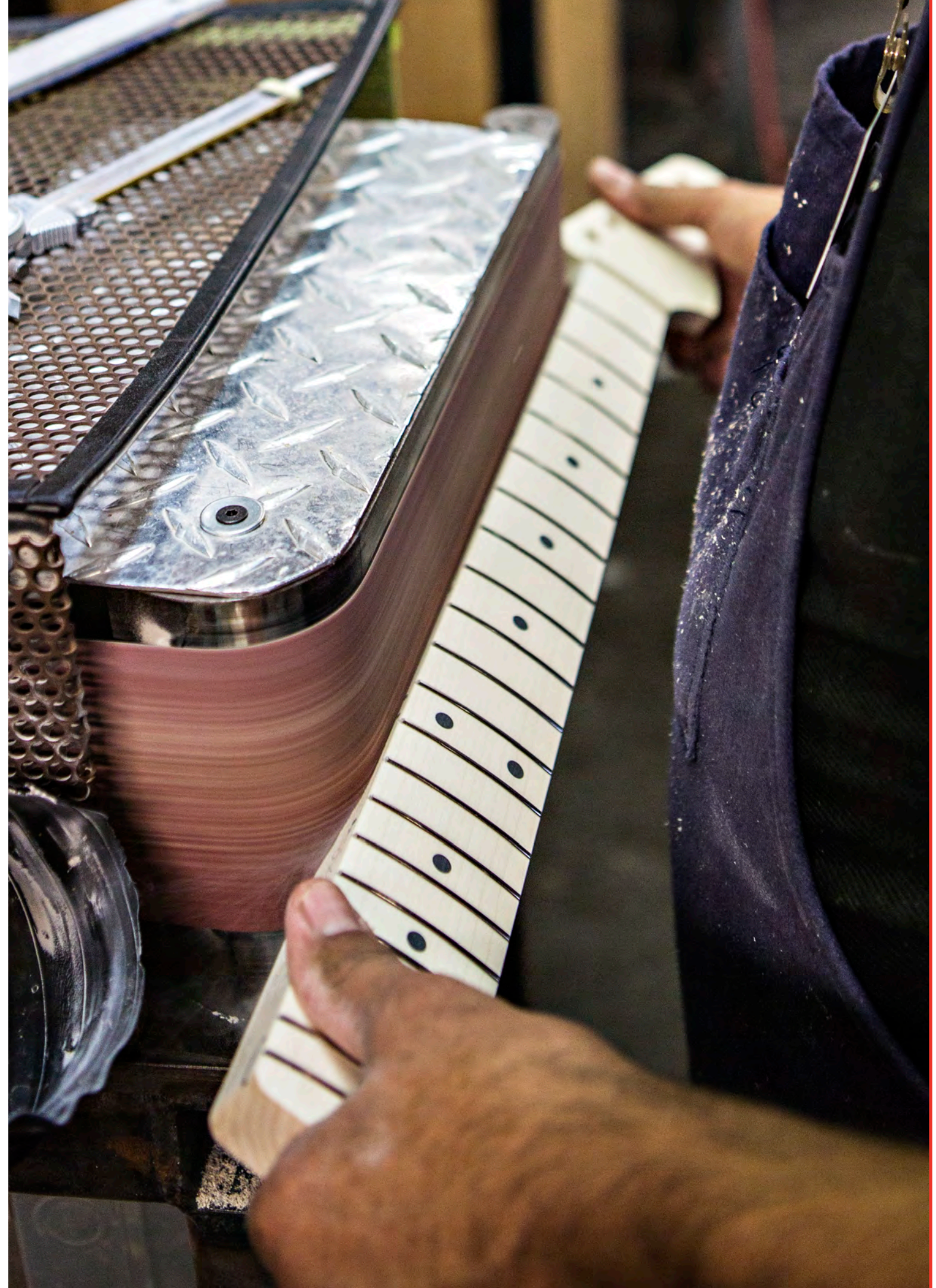

SELECT A FretWire

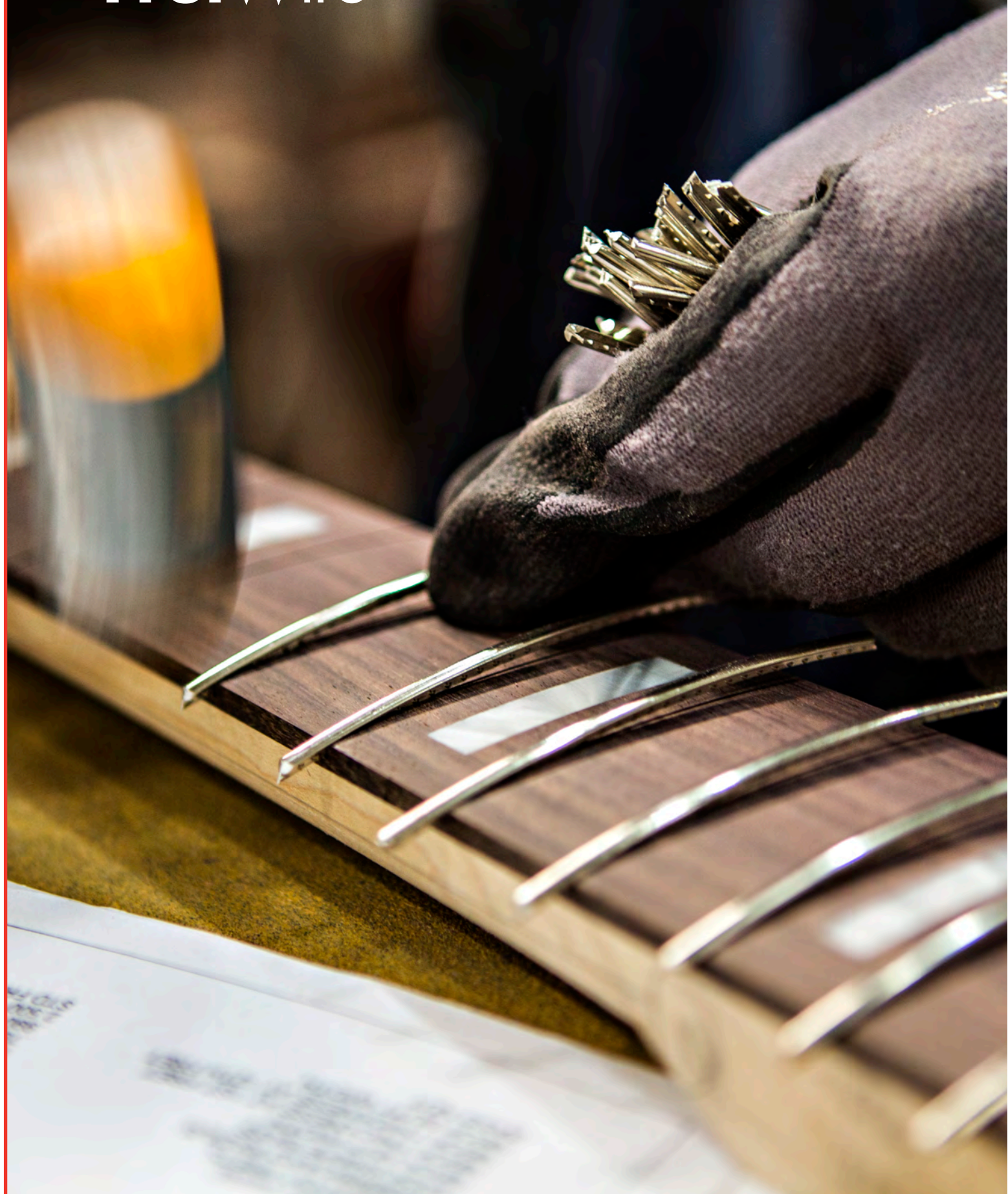

Custom Shop frets are made from only the highest quality nickel, and can be made in a variety of different heights and thicknesses. Larger frets tend to account for easier string bending. Smaller frets are "true to vintage" in many cases, and facilitate easier chording.

Medium jumbo frets are designed to be the perfect marriage between small vintage frets and modern jumbo frets. Keep the following examples in mind when choosing the frets that you want on your guitar:



6100

H: 0.055"
W: 0.110"
Tang W: 0.021"
A very large wire that gives an almost scalloped feel.

6105

H: 0.055"
W: 0.090"
Tang W: 0.020"
Narrow and Tall. Our most popular fret wire.

6150

H: 0.042"
W: 0.102"
Tang W: 0.020"
Wide and Tall. Our "Jumbo" fret.



MEDIUM JUMBO

H: 0.036"
W: 0.106"
Tang W: 0.020"
Wide and Short.
All-purpose fret.

VINTAGE

H: 0.043"
W: 0.080"
Tang W: 0.020"
Our smallest fret wire available.

SELECT A Pickup Option

Hand-Wound: True to Fender history prior to 1965, hand-wound or "scatter-wound" pickups are distinctly unique in character. Each pickup has its own subtle nuances and personalized character which is what made the original Fender pickups so sought after and prized.

Machine Wound: Each pickup is consistent and even in winds making each one sound and respond relatively the same. Though most of the Custom Shop pickups are hand-wound, some players prefer the consistency of machine-wound pickups, so we are happy to offer both options.

STRATOCASTER PICKUPS



'50s STRAT

Crafted to faithfully replicate the cutting tones reminiscent of 1950's Stratocaster® guitars. Alnico 5 magnets, vintage stagger and formvar wire.



FAT '50s STRAT

1950s Stratocaster sound you know and love. Hot-rodged wiring design delivers enhanced bass response and an extra shot of 21st-century attitude.



'60s STRAT

Classic 1960's design with alnico 2 magnets, formvar wire and a vintage stagger. Strat sound with glistening highs and warm punchy lows.



TEXAS SPECIAL™ STRAT

Characterized by their midrange chirp, crystalline highs and tight bass, Fender Texas Special™ Strat pickups feature an overwound single-coil construction that produces big Texas-blues tone.



DUAL-MAG STRAT

Vintage style calibrated pickup set with unbeveled alnico 5 magnets on the bass side and beveled alnico 2 magnets on the treble. The two magnet types create balance and consistency in tone and allow for improved clarity string to string.



EL DIABLO STRAT

Overwound and dipped in the special sauce for a big open sound. Slightly hotter than the Ancho Poblanos with calibrated alnico 5 pickups with custom low G (middle and neck) and flush with high D (bridge) pole pieces.



ANCHO POBLANO STRAT

Simmered in a secret Custom Shop sauce and then individually calibrated from neck to bridge. Uniquely overwound by hand for a wide range of high-output tones—from blistering-hot output to sizzling vintage warmth—with plenty of tonal flexibility.



VINTAGE NOISELESS™ STRAT

Produce all the brilliant clarity, definition and harmonic attributes of vintage single-coil Strat tone without the hum.



FENDER LACE SENSOR® STRAT

Low noise performance inspired by classic, crisp, bell-like Fender tone.

TELECASTER PICKUPS

**'51 TELE/NOCASTER**

Created with the original design in mind to accurately mimic the twang and shimmer of the originals. These period-correct single-coil pickups impart tight low end and clear, balanced midrange.

**'63 TELE**

A true replication of the original '63 Tele Pickups with all the bite and warmth to spare. Alnico 2 Magnets, vintage stagger and enamel wire.

**'67 TELE**

Lower output Tele pickups with Grey bobbins and copper baseplate with a vintage stagger, alnico 5 magnets and enamel wire for crystal clear Tele twang.

**TWISTED TELE**

High-output Telecaster guitar tone with a dash of sparkling Stratocaster® guitar character.

**TEXAS SPECIAL TELE**

Fender Custom Shop Texas Special Tele pickups are built to produce blistering hot output, along with noticeable presence and midrange.

**JOSEFINA RED HOT TELE**

Super-hot Tele pickups with a mid-range growl in the bridge position and a brighter neck pickup for more versatility. Alnico 5 magnets on the bridge and alnico 2 on the neck.

BASS PICKUPS

**'64 JAZZ BASS**

These vintage-style pickups produce warm, clear and articulate tone, with great low-end definition, up-front midrange punch and singing high end.

**'75 JAZZ BASS**

Vintage bobbin construction, Alnico 5 magnets, flush mounted pole pieces and enamel wire provide warm tones, enhanced dynamics and even string response.

**NOISELESS JAZZ BASS**

Fender Noiseless Jazz Bass pickups produce all the brilliant clarity, definition and harmonic attributes of a vintage Jazz Bass without the hum.

PICKUPS HUMBUCKERS

**ENFORCER**

Super-hot high output pickup with dynamic range. Achieves crunchy distortion with full volume and cleans up nicely when rolling back the volume.

**SHAWBUCKER**

Full of multi-dimensional tone with well-defined overtones, this open-coil pickup complements and balances your guitar's natural voice while playing well with other pickup designs.



SELECT A Wiring Option



STRATOCASTER WIRING

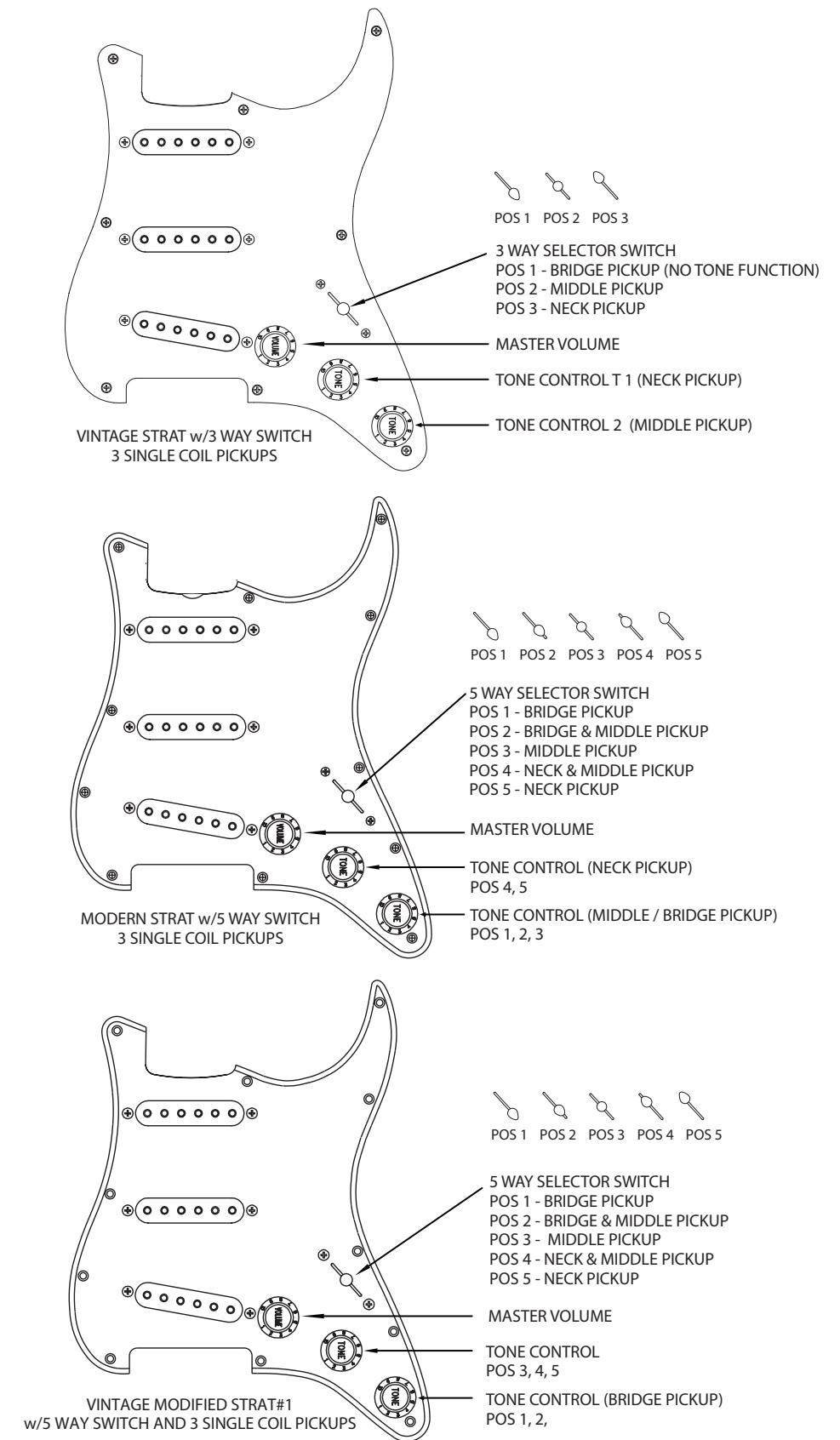

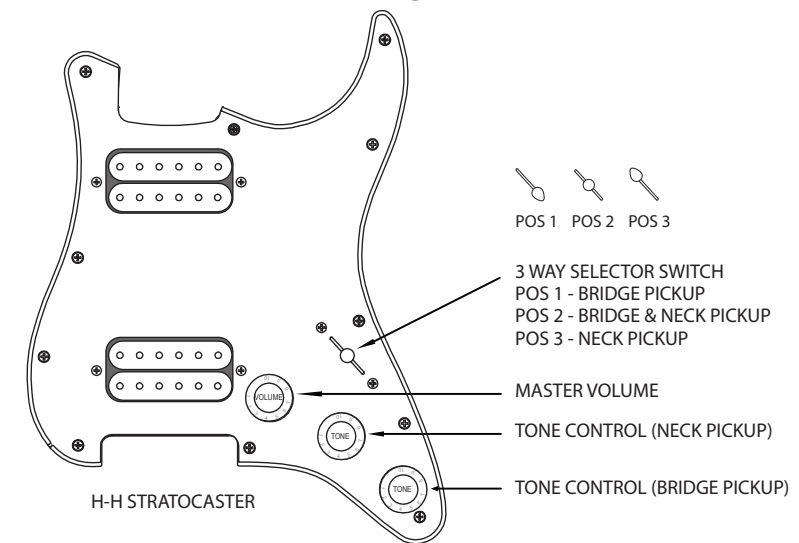
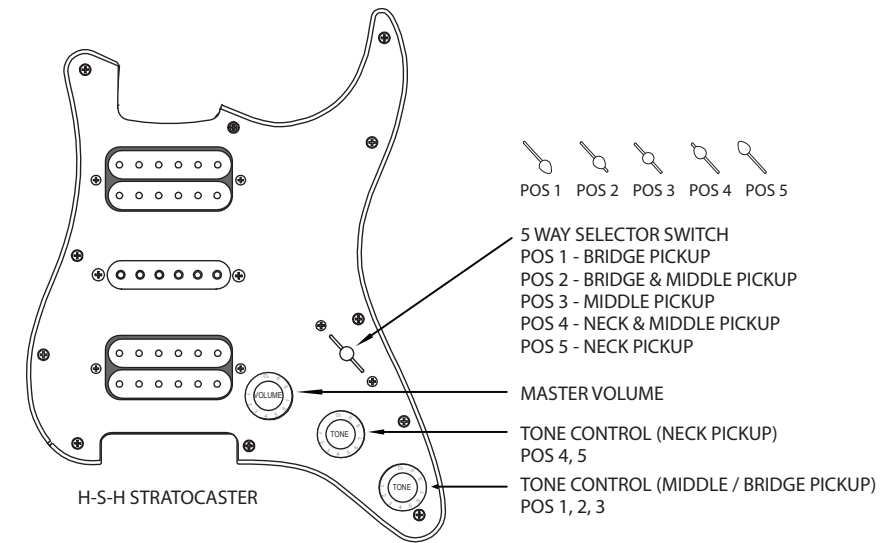
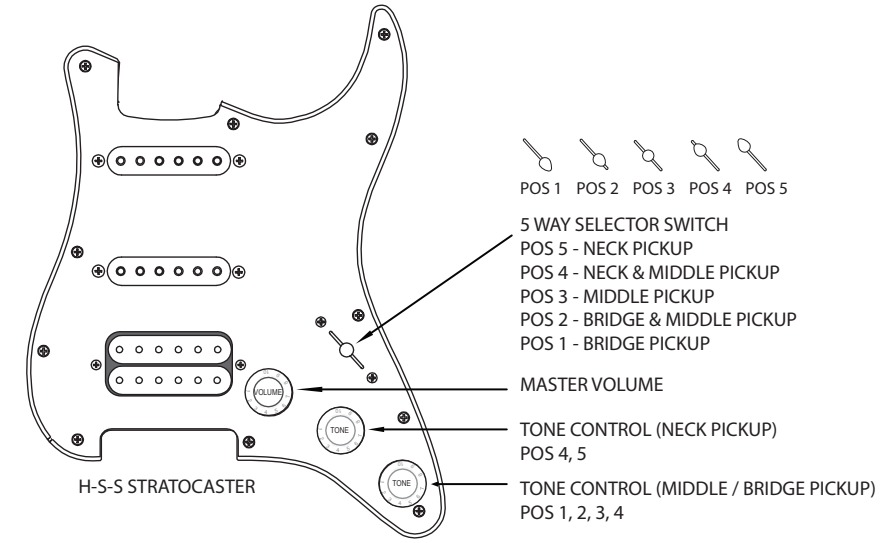
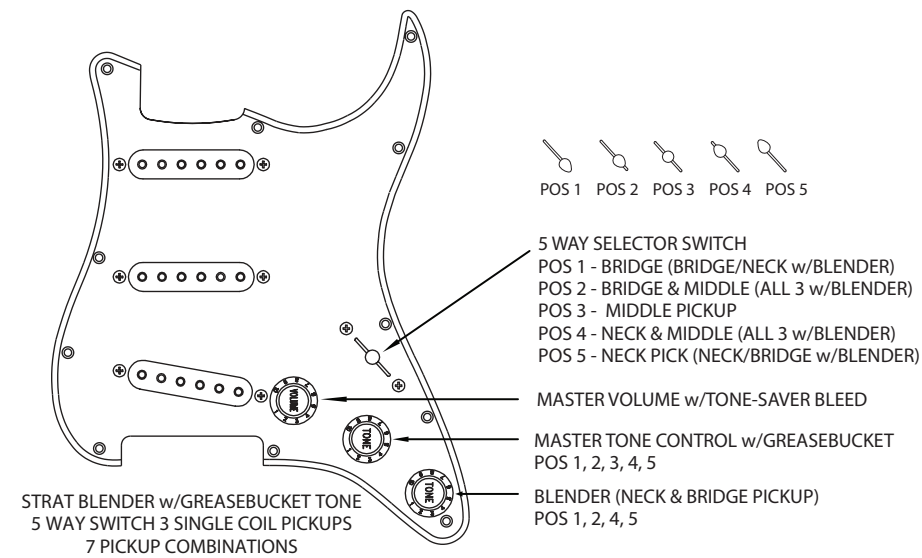
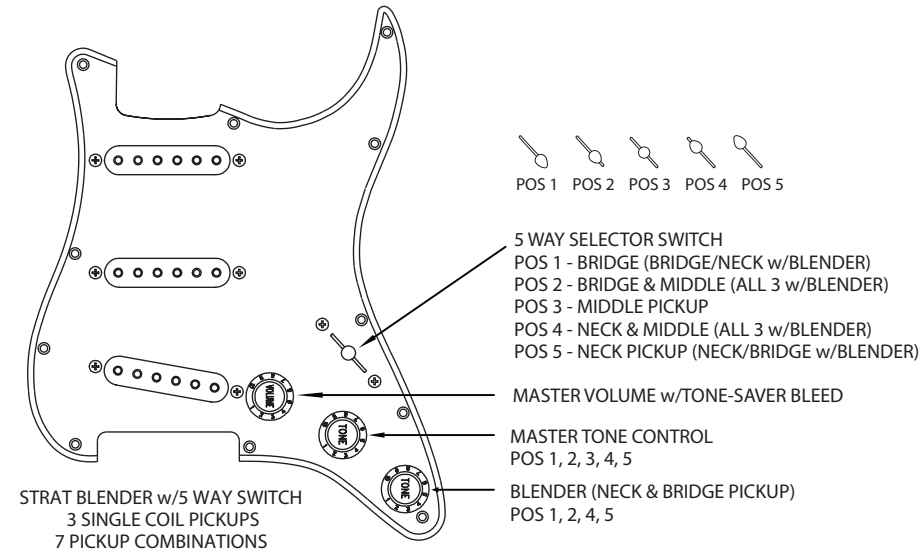
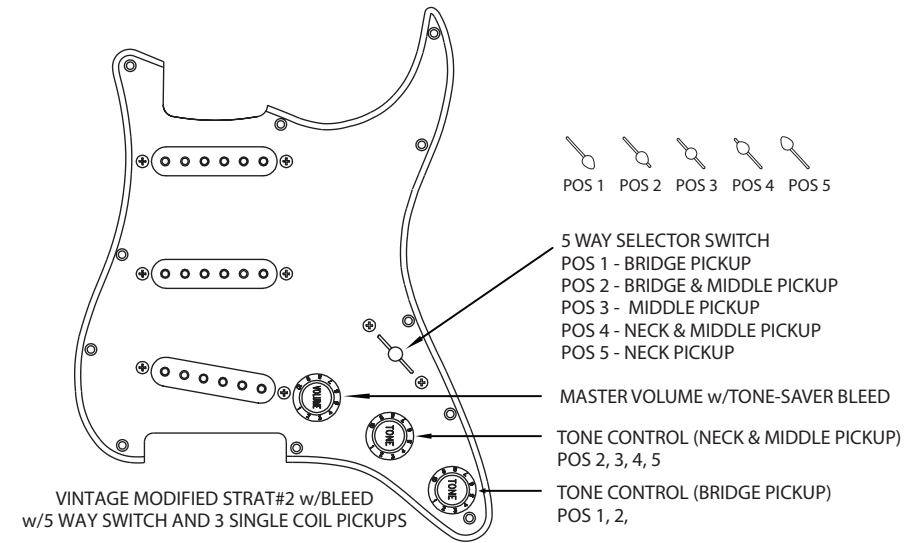

TELECASTER WIRING

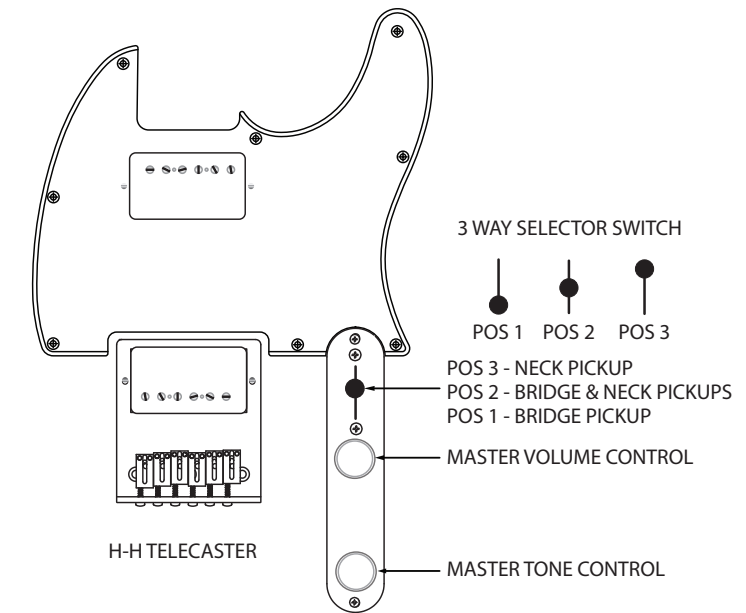
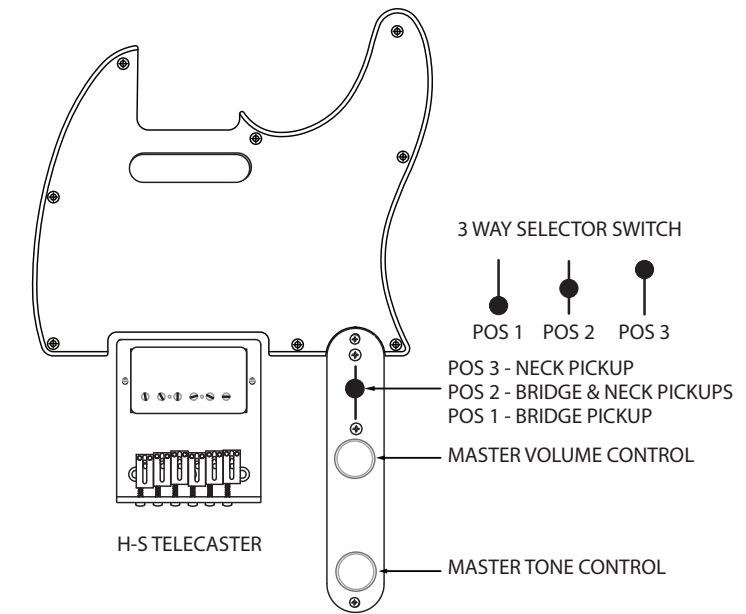
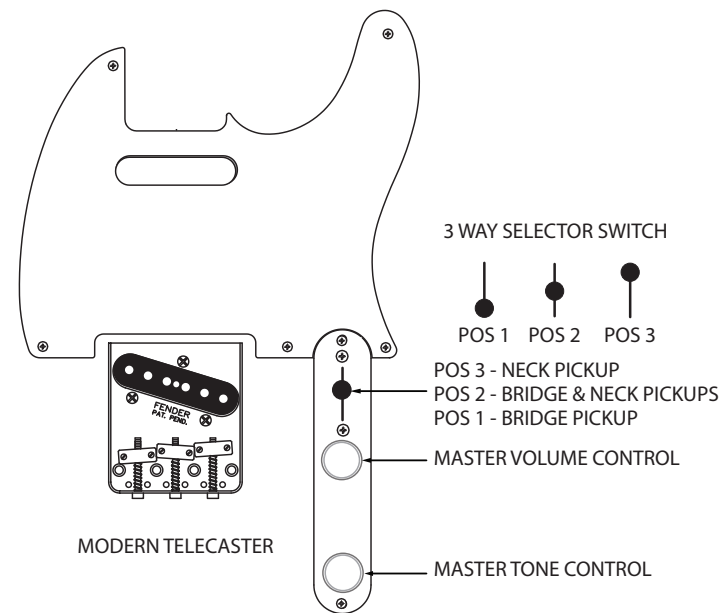
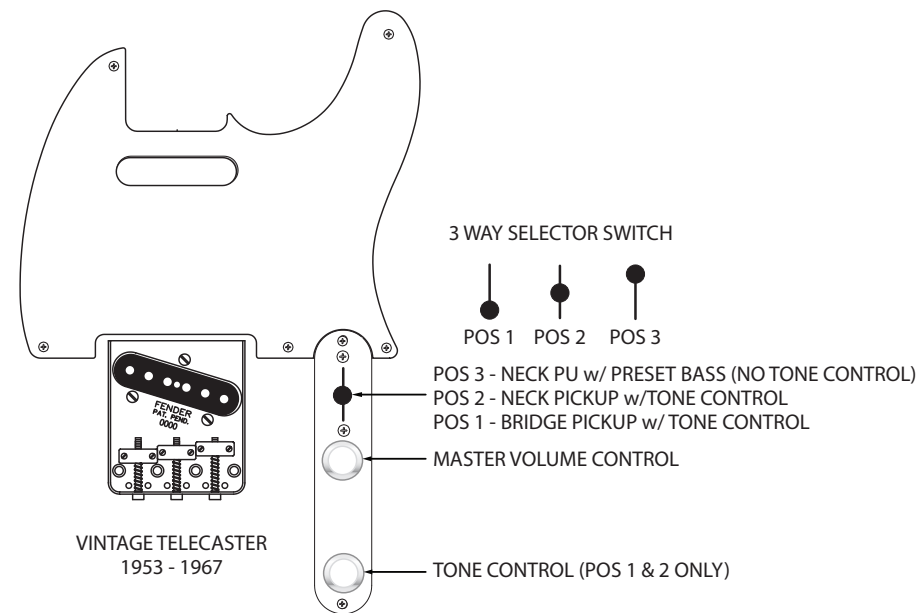
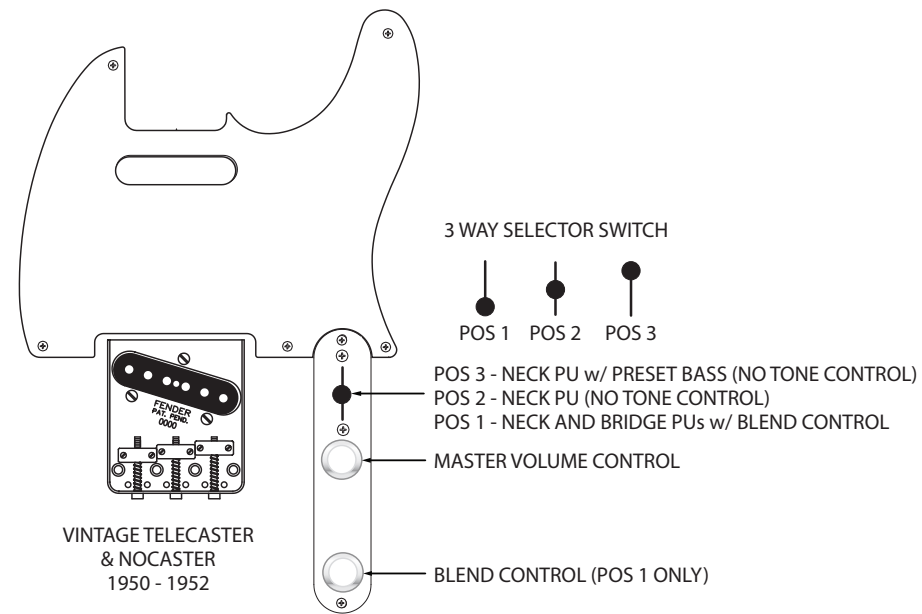

PRECISION BASS WIRING

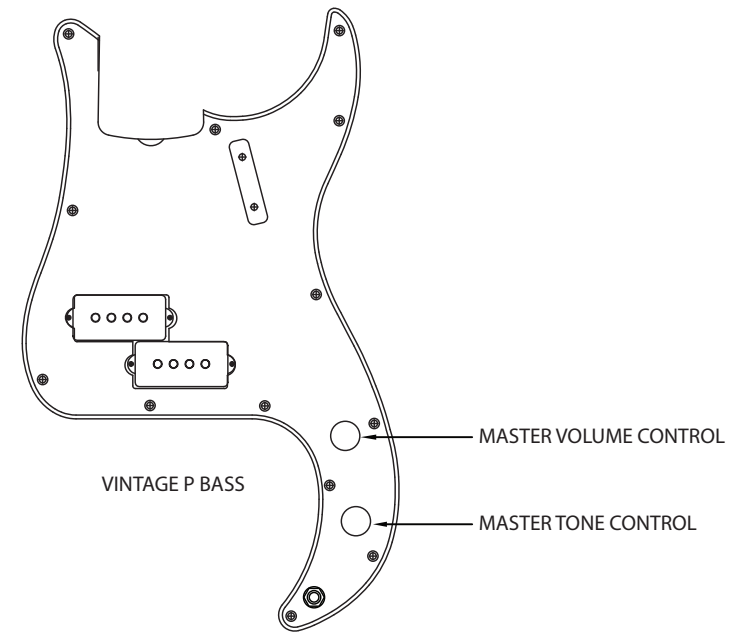

JAZZ BASS WIRING

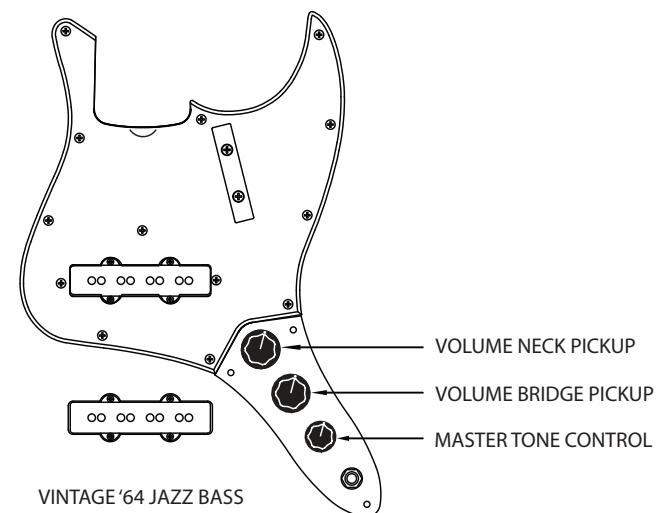
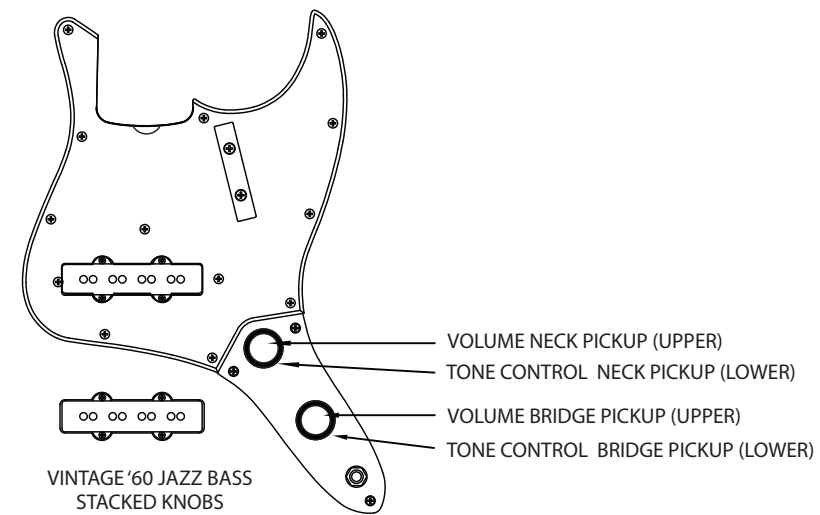

SELECT A Hardware Option



Bliss Model 21 1/2, 60 Ton punch built in 1958. Purchased new by Leo Fender.

BRIDGES STRATOCASTER



VINTAGE SYNCHRONIZED TREMOLO

Original Stratocaster tremolo made using original die-cast moulds and punch presses purchased by Leo Fender.



2-POINT CUSTOM CLASSIC TREMOLO

Polished steel two-point synchronized tremolo bridge assembly.



VINTAGE HARD-TAIL

Vintage stamped saddles, chrome plated bridge, and string through body design.



RSD STRAT

Vintage style with improved pivot geometry, plating tolerances, string spacing and arm tension adjustment.



FLOYD ROSE®

Double-locking tremolo bridge, recessed for pick hand comfort providing laser-accurate intonation and ultra-stable tuning when combined with the Floyd Rose R3 locking nut.

BRIDGES TELECASTER



'51-'53 TELECASTER - BRASS SADDLES

Telecaster ashtray bridge plate with original tooling marks, serial number and 3 brass saddles.



'60 & UP TELECASTER - THREADED SADDLES

Period correct ashtray bridge plate and threaded steel saddles for bright Tele twang. (Relic saddles shown)



'67 TELE - STEEL SADDLES

Vintage style ashtray bridge plate with notched steel saddles.



RSD TELE

Low profile bridge plate, compensated brass saddles with refined look and feel.



CUSTOM DELUXE TELE

Modern six-saddle bridge assembly with string-through-body plate, and polished steel saddles.

BRIDGES BASS



VINTAGE THREADED SADDLES

Genuine Fender bass bridge assembly with nickel-plated steel bridge plate and four threaded barrel saddles.



VINTAGE GROOVE SADDLES

Vintage Fender bass bridge assembly with nickel-plated steel bridge plate and four grooved barrel saddles.



MODERN BASS BRIDGE

Chrome plated steel bridge plate with partially threaded stainless steel saddles and string through body or top load option.



RSD BASS

Hi-Mass Bridge constructed from a solid brass billet with threaded steel saddles.

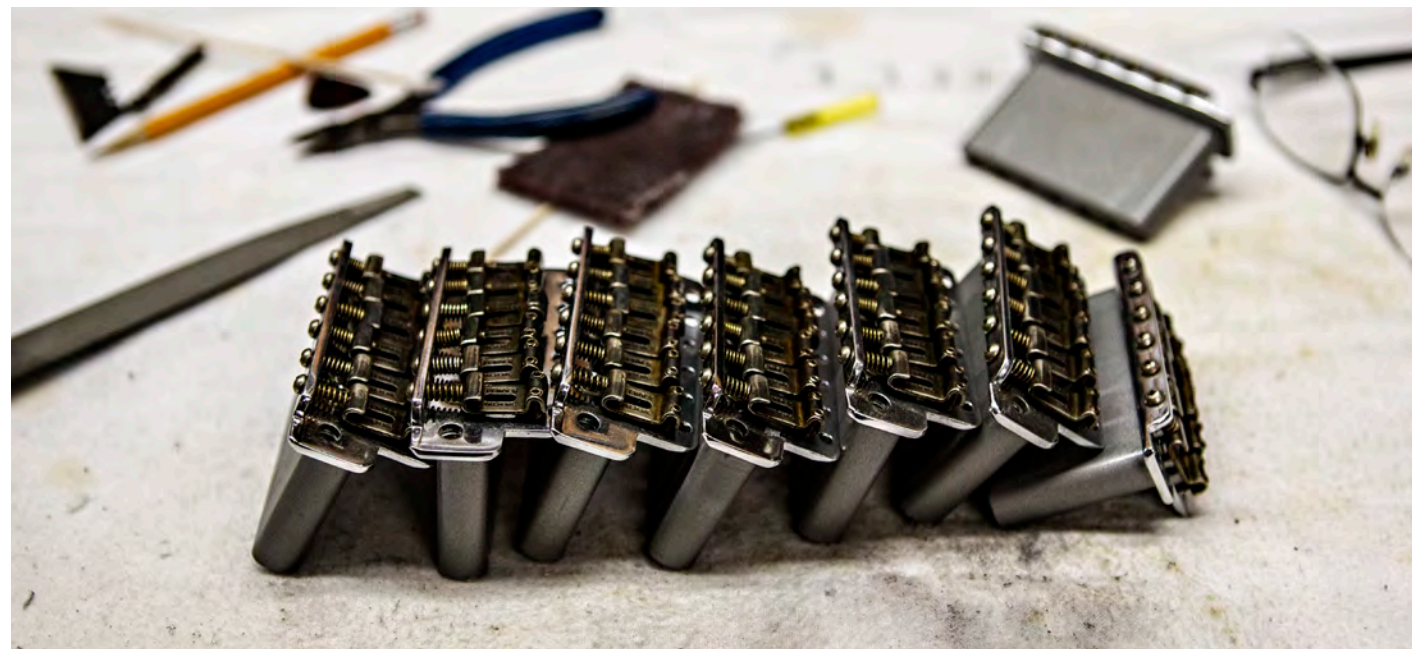

Original Bridge Plate Punch Press, still in use after 50 years



Model Shown: 1952 Telecaster Heavy Relic White Blonde

DesignGuide

BUILD LEVEL (SELECT ONE)

- MASTERBUILT
SELECT BUILDER _____
- CUSTOM-BUILT

BASE MODEL

*FOR BASE MODEL SPECIFICATIONS, START AT PAGE 23

STRATOCASTER

- 1955 STRATOCASTER
- 1956 STRATOCASTER
- OTHER 1950'S STRATOCASTER _____
- 1960 STRATOCASTER
- 1963 STRATOCASTER
- 1965 STRATOCASTER
- 1969 STRATOCASTER
- OTHER 1960'S STRATOCASTER _____

NOCASTER/TELECASTER/ESQUIRE

- 1951 NOCASTER
- 1952 TELECASTER
- OTHER 1950'S TELECASTER _____
- 1960 TELECASTER
- 1960 TELECASTER CUSTOM
- 1963 TELECASTER
- 1967 TELECASTER
- OTHER 1960'S TELECASTER _____
- 1959 ESQUIRE
- OTHER YEAR ESQUIRE _____ (THRU '69)
- 1950'S THINLINE TELECASTER

JAZZMASTER/JAGUAR/BASS VI

- 1962 JAZZMASTER
- OTHER YEAR JAZZMASTER _____ (THRU '65)
- 1962 JAGUAR
- OTHER YEAR JAGUAR _____ (THRU '65)
- BASS VI

FENDER BASS

- 1955 PRECISION BASS
- 1959 PRECISION BASS
- 1960 PRECISION BASS
- OTHER YEAR PRECISION BASS _____ (THRU '69)
- 1964 JAZZ BASS
- OTHER YEAR JAZZ BASS _____ (THRU '75)

AGING TYPE (SELECT ONE)

- NOS
- CLOSET CLASSIC
- LUSH CLOSET CLASSIC
- JOURNEYMAN RELIC
- RELIC
- HEAVY RELIC

CUSTOM OPTIONS

CONSTRUCTION

- LEFT HANDED GUITAR
- SET NECK
- BODY BINDING 1 SIDE – TELE ONLY
- BODY BINDING 2 SIDES – TELE ONLY
- REVERSE HEADSTOCK
- CONTOURED NECK HEEL
- BOUND FINGERBOARD

BODY WOOD (SELECT FROM PAGE 29)

- BASE MODEL BODY WOOD*
- SORT FOR LIGHT WEIGHT BODY WOOD
- ASH
- MAHOGANY
- ADD ROASTED BODY WOOD OPTION
- OTHER BODY WOOD _____
- FLAME MAPLE TOP
- QUILTED MAPLE TOP
- OTHER EXOTIC WOOD _____

BODY COLOR (SELECT FROM PAGE ##)

- SINGLE COLOR # _____
- COLOR OVER COLOR # _____ O # _____
- SPARKLE COLOR # _____

BODY FINISH

- BASE MODEL FINISH*
- NITROCELLULOSE LACQUER
- POLYURETHANE

NECK WOOD

- BASE MODEL NECK WOOD*
- STRAIGHT GRAIN MAPLE
- RIFT SAWN MAPLE
- QUARTERSAWN MAPLE
- "AA" FLAME MAPLE
- "AAA" FLAME MAPLE
- "AA" BIRDSEYE MAPLE
- "AAA" BIRDSEYE MAPLE
- ADD ROASTED NECK WOOD OPTION

NECK TINT

- NO TINT
- LIGHT TINT
- MEDIUM TINT
- DARK TINT

NECK FINISH

- NITRO LACQUER
- URETHANE
- SATIN URETHANE
- PAINTED HEADCAP

*For base model specifications see page 23

CUSTOM OPTIONS

NECK SHAPE

- BASE MODEL NECK SHAPE*
- CUSTOM NECK SHAPE # _____ (START AT PAGE 36)

FINGERBOARD WOOD

- BASE MODEL FINGERBOARD*
- 1-PIECE MAPLE NECK
- ROUND-LAM MAPLE
- SLAB ROSEWOOD
- ROUND-LAM ROSEWOOD
- SORT FOR DARK ROSEWOOD
- EBONY

FINGERBOARD RADIUS

- BASE MODEL FINGERBOARD RADIUS*
- 7.25"
- 9.50"
- 12.00"
- 7.25" TO 9.5" COMPOUND RADIUS
- 7.25" TO 12" COMPOUND RADIUS
- 9.5" TO 12" COMPOUND RADIUS
- 9.5" TO 16" COMPOUND RADIUS (BASS ONLY)

WIDTH AT NUT

- BASE MODEL NUT WIDTH*
- 1.650"
- 1.6875"

NUT MATERIAL

- BASE MODEL NUT MATERIAL*
- MICARTA
- BONE
- GRAPHITE
- LSR ROLLERNUT

FRET WIRE

- BASE MODEL FRET WIRE*
- VINTAGE
- MEDIUM JUMBO
- 6100
- 6105
- 6150

POSITION & SIDE MARKERS

- BASE MODEL DOT MATERIAL*
- VINTAGE BLACK
- VINTAGE CLAY
- WHITE
- PEARL WHITE
- BLOCK INLAYS

12TH FRET DOT SPACING

- BASE MODEL DOT SPACING*
- WIDE 12TH FRET DOT SPACING
- NARROW 12TH FRET DOT SPACING

HARDWARE COLOR

- BASE MODEL HARDWARE COLOR*
- NICKEL/CHROME
- GOLD

BRIDGE

- BASE MODEL BRIDGE ASSEMBLY*

STRATOCASTER BRIDGE

- VINTAGE SYNCHRONIZED TREMOLO
- 2-POINT CLASSIC PLAYER TREMOLO
- 2-POINT CUSTOM CLASSIC TREMOLO
- RSD STRAT TREMOLO
- FLOYD ROSE® ORIGINAL
- VINTAGE HARD-TAIL
- CUSTOM CLASSIC HARDTAIL

TELECASTER BRIDGE

- '51 - '53 TELECASTER - BRASS SADDLES
- '54 - '57 TELECASTER - STEEL SADDLES
- '60 & UP TELECASTER - THREADED SADDLES
- '67 TELE - STEEL SADDLES
- CUSTOM DELUXE TELE BRIDGE
- RSD TELE BRIDGE

PRECISION/JAZZ BASS

- VINTAGE 2-SADDLE BRIDGE
- VINTAGE THREADED SADDLES BRIDGE
- VINTAGE GROOVE SADDLES BRIDGE
- MODERN BASS BRIDGE
- RSD BASS BRIDGE

JAZZMASTER/JAGUAR/BASS VI

- BASE MODEL BRIDGE*
- RSD J-BRIDGE (NEW)

TUNING MACHINES

- BASE MODEL TUNING MACHINES*
- VINTAGE STYLE
- VINTAGE-STAGGERED
- VINTAGE LOCKING
- SPERZEL DELUXE
- SPERZEL DELUXE W/ PEARL BUTTONS
- SPERZEL TRIM-LOK™
- FENDER/SCHALLER "F"

PICKGUARD

- BASE MODEL PICKGUARD*
- 1-PLY EGGSHELL WHITE
- 1-PLY PARCHMENT WHITE
- 1-PLY BLACK
- 1-PLY BLACK PHENOLIC LAMINATE
- 3-PLY EGGSHELL WHITE
- 3-PLY PARCHMENT WHITE
- 3-PLY MINT GREEN
- 3-PLY BLACK
- 4-PLY BROWN SHELL
- ANODIZED GOLD
- OTHER _____

CUSTOM OPTIONS

CONTROL KNOBS

- BASE MODEL KNOBS*

STRATOCASTER KNOBS

- WHITE
- EGGSHELL WHITE
- PARCHMENT WHITE
- VINTAGE WHITE
- BLACK

TELECASTER/PRECISION BASS KNOBS BRIDGE

- VINTAGE KNURLED
- ALUMINUM KNURLED

STRAT PICKUP COVERS

- BASE MODEL COVERS*
- WHITE
- EGGSHELL WHITE
- PARCHMENT WHITE
- VINTAGE WHITE
- AGED WHITE
- BLACK
- LIPSTICK COVERS

WIRING (SEE PAGE 48 FOR ILLUSTRATIONS)

- BASE MODEL WIRING*

STRATOCASTER WIRING

- VINTAGE STRAT
- FAT 50'S HOOK-UP
- MODERN STRAT
- VINTAGE MODIFIED STRAT #1
- VINTAGE MODIFIED STRAT #2 W/ BLEED
- STRAT BLENDER W/ BLEED
- STRAT BLENDER W/ BLEED & GREASEBUCKET
- H-S-S CONFIGURATION
- H-S-H CONFIGURATION
- H-H CONFIGURATION

TELECASTER WIRING

- VINTAGE TELE WIRING 1950-1952
- VINTAGE TELE WIRING 1953-1967
- MODERN TELE WIRING
- MODERN TELE W/ GREASEBUCKET TONE
- H-S CONFIGURATION
- H-H CONFIGURATION

BASS WIRING

- VINTAGE P BASS WIRING
- VINTAGE JAZZ BASS W/ STACKED KNOBS
- VINTAGE 64 JAZZ BASS

MISCELLANEOUS ELECTRONICS

- 5-WAY SWITCH (STRAT)
- TONE-SAVER TREBLE BLEED
- GREASEBUCKET TONE CONTROL
- TBX TONE CONTROL
- NO-LOAD TONE CONTROL
- S-1 SWITCH
- S-1 FUNCTION _____

PICKUPS

	N	M	B
BASE MODEL PICKUPS*	<input type="checkbox"/>	<input type="checkbox"/>	<input type="checkbox"/>
RWRP MIDDLE PICKUP	<input type="checkbox"/>	<input type="checkbox"/>	<input type="checkbox"/>
STRAT PICKUPS - FENDER CUSTOM SHOP			
'50S STRAT	<input type="checkbox"/>	<input type="checkbox"/>	<input type="checkbox"/>
FAT '50S STRAT	<input type="checkbox"/>	<input type="checkbox"/>	<input type="checkbox"/>
'60S STRAT	<input type="checkbox"/>	<input type="checkbox"/>	<input type="checkbox"/>
FAT '60S STRAT	<input type="checkbox"/>	<input type="checkbox"/>	<input type="checkbox"/>
'58 STRAT	<input type="checkbox"/>	<input type="checkbox"/>	<input type="checkbox"/>
'65 STRAT	<input type="checkbox"/>	<input type="checkbox"/>	<input type="checkbox"/>
'66 STRAT	<input type="checkbox"/>	<input type="checkbox"/>	<input type="checkbox"/>
'69 STRAT	<input type="checkbox"/>	<input type="checkbox"/>	<input type="checkbox"/>
TEXAS SPECIAL™ STRAT	<input type="checkbox"/>	<input type="checkbox"/>	<input type="checkbox"/>
MASTER DESIGN STRAT	<input type="checkbox"/>	<input type="checkbox"/>	<input type="checkbox"/>
HAND WOUND STRAT PICKUPS - FENDER CUSTOM SHOP			
HW '50S STRAT	<input type="checkbox"/>	<input type="checkbox"/>	<input type="checkbox"/>
HW FAT '50S STRAT	<input type="checkbox"/>	<input type="checkbox"/>	<input type="checkbox"/>
HW '60S STRAT	<input type="checkbox"/>	<input type="checkbox"/>	<input type="checkbox"/>
HW FAT '60S STRAT	<input type="checkbox"/>	<input type="checkbox"/>	<input type="checkbox"/>
HW '55 STRAT	<input type="checkbox"/>	<input type="checkbox"/>	<input type="checkbox"/>
HW '56 STRAT	<input type="checkbox"/>	<input type="checkbox"/>	<input type="checkbox"/>
HW '57 STRAT	<input type="checkbox"/>	<input type="checkbox"/>	<input type="checkbox"/>
HW '59 STRAT	<input type="checkbox"/>	<input type="checkbox"/>	<input type="checkbox"/>
HW '60/'63 STRAT	<input type="checkbox"/>	<input type="checkbox"/>	<input type="checkbox"/>
HW '64 STRAT	<input type="checkbox"/>	<input type="checkbox"/>	<input type="checkbox"/>
HW '65 STRAT	<input type="checkbox"/>	<input type="checkbox"/>	<input type="checkbox"/>
HW '66 STRAT	<input type="checkbox"/>	<input type="checkbox"/>	<input type="checkbox"/>
HW '69 STRAT	<input type="checkbox"/>	<input type="checkbox"/>	<input type="checkbox"/>
HW TEXAS SPECIAL STRAT	<input type="checkbox"/>	<input type="checkbox"/>	<input type="checkbox"/>
HW MASTER DESIGN STRAT	<input type="checkbox"/>	<input type="checkbox"/>	<input type="checkbox"/>
HW DUAL-MAG STRAT (NEW)	<input type="checkbox"/>	<input type="checkbox"/>	<input type="checkbox"/>
HW EL DIABLO STRAT (NEW)	<input type="checkbox"/>	<input type="checkbox"/>	<input type="checkbox"/>
HW ANCHO POBLANO STRAT	<input type="checkbox"/>	<input type="checkbox"/>	<input type="checkbox"/>
OTHER STRAT PICKUPS			
FENDER NOISELESS™	<input type="checkbox"/>	<input type="checkbox"/>	<input type="checkbox"/>
DUNCAN® HOT RAILS™ SLDS-1	<input type="checkbox"/>	<input type="checkbox"/>	<input type="checkbox"/>
DUNCAN HOT SSL 3	<input type="checkbox"/>	<input type="checkbox"/>	<input type="checkbox"/>
DUNCAN LI'L SCREAMIN' DEMON™	<input type="checkbox"/>	<input type="checkbox"/>	<input type="checkbox"/>
DUNCAN LIPSTICK TUBE SLS-1	<input type="checkbox"/>	<input type="checkbox"/>	<input type="checkbox"/>

PICKUPS

PICKUPS	N	M	B
TELE PICKUPS - FENDER CUSTOM SHOP			
'51 TELECASTER/NOCASTER	<input type="checkbox"/>	-	<input type="checkbox"/>
'56/'57 TELE	<input type="checkbox"/>	-	<input type="checkbox"/>
'63 TELE	<input type="checkbox"/>	-	<input type="checkbox"/>
'67 TELE	<input type="checkbox"/>	-	<input type="checkbox"/>
TWISTED TELE	<input type="checkbox"/>	-	<input type="checkbox"/>
HAND WOUND TELE PICKUPS - FENDER CUSTOM SHOP			
HW ORIGINAL "BLACKGUARD BC"	<input type="checkbox"/>	-	-
HW '51 TELECASTER/NOCASTER	<input type="checkbox"/>	-	<input type="checkbox"/>
HW '55/'56 TELE	<input type="checkbox"/>	-	<input type="checkbox"/>
HW '58 TELE	<input type="checkbox"/>	-	<input type="checkbox"/>
HW '63 TELE	<input type="checkbox"/>	-	<input type="checkbox"/>
HW '67 TELE	<input type="checkbox"/>	-	<input type="checkbox"/>
HW TWISTED TELE	<input type="checkbox"/>	-	<input type="checkbox"/>
HW TEXAS SPECIAL TELE	<input type="checkbox"/>	-	<input type="checkbox"/>
HW RED HOT TELE	<input type="checkbox"/>	-	<input type="checkbox"/>
OTHER TELE PICKUPS			
FENDER NOISELESS	<input type="checkbox"/>	-	<input type="checkbox"/>
DUNCAN FIVE-TWO™ TELE	<input type="checkbox"/>	-	<input type="checkbox"/>
DUNCAN QUARTER POUND	<input type="checkbox"/>	-	<input type="checkbox"/>
DUNCAN LITTLE '59™	<input type="checkbox"/>	-	<input type="checkbox"/>
DUNCAN VINTAGE RHYTHM STR-1	<input type="checkbox"/>	-	<input type="checkbox"/>
HUMBUCKING PICKUPS			
EVH® HUMBUCKING	<input type="checkbox"/>	-	<input type="checkbox"/>
FENDER SHAWBUCKER	<input type="checkbox"/>	-	<input type="checkbox"/>
ENFORCER™ HUMBUCKING	<input type="checkbox"/>	-	<input type="checkbox"/>
FENDER HB HOT ROD WIDE WHITE	<input type="checkbox"/>	-	-
DUNCAN 59™ SH-1 NECK	<input type="checkbox"/>	-	-
DUNCAN 59 SH-4 BRIDGE	-	-	<input type="checkbox"/>
DUNCAN ALNICO II PRO™ APH-1	<input type="checkbox"/>	-	<input type="checkbox"/>
DUNCAN ALNICO II PRO TBAPH-1	<input type="checkbox"/>	-	<input type="checkbox"/>
DUNCAN DISTORTION TREMUCKER™	<input type="checkbox"/>	-	<input type="checkbox"/>
DUNCAN PEARLY GATES™ SH-PG1	<input type="checkbox"/>	-	<input type="checkbox"/>
DUNCAN SCREAMIN' DEMON™	<input type="checkbox"/>	-	<input type="checkbox"/>
DUNCAN DISTORTION™ SH-6	<input type="checkbox"/>	-	<input type="checkbox"/>
DUNCAN LIVEWIRE CLASSIC	<input type="checkbox"/>	-	<input type="checkbox"/>
DUNCAN INVADER SH-8	<input type="checkbox"/>	-	<input type="checkbox"/>
DUNCAN TREMUCKER™	<input type="checkbox"/>	-	<input type="checkbox"/>
TV JONES® CLASSIC (TELE ONLY)	<input type="checkbox"/>	-	<input type="checkbox"/>
TV JONES CLASSIC PLUS (TELE ONLY)	<input type="checkbox"/>	-	<input type="checkbox"/>

HUMBUCKING PICKUPS CONT.	N	M	B
TV JONES POWER'TRON (TELE ONLY)	<input type="checkbox"/>	-	<input type="checkbox"/>
TV JONES POWER'TRON PLUS (TELE ONLY)	<input type="checkbox"/>	-	<input type="checkbox"/>
TV JONES SUPER'TRON (TELE ONLY)	<input type="checkbox"/>	-	<input type="checkbox"/>
TV JONES MAGNA'TRON (TELE ONLY)	<input type="checkbox"/>	-	<input type="checkbox"/>
P-90®	<input type="checkbox"/>	-	<input type="checkbox"/>
BASS PICKUPS			
PRECISION BASS PICKUPS			
'55 PRECISION BASS	-	<input type="checkbox"/>	-
'57 PRECISION BASS	-	<input type="checkbox"/>	-
'59 - '62 PRECISION BASS	-	<input type="checkbox"/>	-
'59 - '62 PRECISION BASS (FLAT POLES)	-	<input type="checkbox"/>	-
HW '55 PRECISION BASS	-	<input type="checkbox"/>	-
HW '57 PRECISION BASS	-	<input type="checkbox"/>	-
HW '62 PRECISION BASS	-	<input type="checkbox"/>	-
JAZZ BASS PICKUPS			
'60S JAZZ BASS	<input type="checkbox"/>	-	<input type="checkbox"/>
'75 JAZZ BASS	<input type="checkbox"/>	-	<input type="checkbox"/>
CUSTOM CLASSIC JAZZ BASS	<input type="checkbox"/>	-	<input type="checkbox"/>
HW '60S JAZZ BASS	<input type="checkbox"/>	-	<input type="checkbox"/>
HW '75 JAZZ BASS	<input type="checkbox"/>	-	<input type="checkbox"/>
JAZZMASTER/JAGUAR/BASS VI PICKUPS			
VINTAGE JAZZMASTER	<input type="checkbox"/>	-	<input type="checkbox"/>
HW VINTAGE JAZZMASTER	<input type="checkbox"/>	-	<input type="checkbox"/>
VINTAGE JAGUAR/BASS VI	<input type="checkbox"/>	-	<input type="checkbox"/>

PICKUP SPECS

HAND-WOUND	NOMINAL DC RESISTANCE +/- 10%				WIRE	MAGNETS	STAGGER	NOTES
	NECK	MIDDLE	MID-RWRP	BRIDGE				
H/W 50'S STRAT	6.12K	6.12K	6.12K		FORMVAR	ALNICO 5	VINTAGE	CALIBRATED SET
H/W 50'S STRAT				6.39K	FORMVAR	ALNICO 5	CUSTOM LOW G	
H/W FAT 50'S STRAT	6.26K		6.34K	6.48K	FORMVAR	ALNICO 5	VINTAGE	CALIBRATED SET
H/W 55 STRAT	5.60K	5.60K		5.60K	FORMVAR	ALNICO 3	VINTAGE LOW G	
H/W 56 STRAT	5.98K		5.98K	6.22K	FORMVAR	ALNICO 5	CUSTOM LOW G	CALIBRATED SET
H/W 57 STRAT	6.02K		6.02K	6.39K	FORMVAR	ALNICO 5	VINTAGE	CALIBRATED SET
H/W 59 STRAT	5.80K	5.80K		5.80K	FORMVAR	ALNICO 5	VINTAGE	
HW 60'S STRAT	5.83K	5.83K	5.83K	5.83K	FORMVAR	ALNICO 2	VINTAGE	
HW FAT 60'S STRAT	6.64K	6.64K	6.64K	6.64K	FORMVAR	ALNICO 2	VINTAGE	
H/W 60-63 STRAT	6.20K		6.35K	6.47K	FORMVAR	ALNICO 5	VINTAGE	CALIBRATED SET
H/W 64 STRAT	5.31K		5.56K	5.81K	ENAMEL	ALNICO 5	VINTAGE	CALIBRATED SET
H/W 65 STRAT	6.27K	6.27K	6.27K	6.27K	POLYSOL	ALNICO 5	VINTAGE	
H/W 69 STRAT	5.61K	5.61K	5.61K	5.61K	ENAMEL	ALNICO 5	VINTAGE	
H/W TEXAS SPECIAL STRAT	5.94K		6.27K	6.56K	ENAMEL	ALNICO 5	VINTAGE	CALIBRATED SET
H/W MASTER DESIGN STRAT	6.45K		6.45K		FORMVAR	ALNICO 5	VINTAGE	CALIBRATED SET
H/W MASTER DESIGN STRAT				6.84K	ENAMEL	ALNICO 5	FLUSH	
H/W POBLANO STRAT	6.25K		6.47K		FORMVAR	ALNICO 3	VINTAGE LOW G	CALIBRATED SET
H/W POBLANO STRAT				6.27K	ENAMEL	ALNICO 5	FLUSH	
H/W EL DIABLO STRAT	5.55K		5.93K		ENAMEL	ALNICO 5	CUSTOM LOW G	CALIBRATED SET
H/W EL DIABLO STRAT				6.34K	ENAMEL	ALNICO 5	FLUSH w/ HIGH "D"	
H/W DUAL-MAG	5.79K	6.05K	6.05K	6.27K	FORMVAR	ALNICO 5 UNBEVELED	VINTAGE	CALIBRATED SET
H/W DUAL-MAG	5.79K	6.05K	6.05K	6.27K	FORMVAR	ALNICO 2 BEVELED	VINTAGE	

NON HAND-WOUND STRAT	NOMINAL DC RESISTANCE +/- 10%				WIRE	MAGNETS	STAGGER	NOTES
	NECK	MIDDLE	MID-RWRP	BRIDGE				
50S STRATOCASTER	6.12K	6.12K	6.12K	6.39K	FORMVAR	ALNICO 5	VINTAGE	
60S STRATOCASTER	5.83K	5.83K	5.83K	5.83K	FORMVAR	ALNICO 2	VINTAGE	
65 STRATOCASTER	6.27K	6.27K	6.27K	6.27K	POLYSOL	ALNICO 5	VINTAGE	
66 STRATOCASTER	5.61K	5.61K	5.61K	5.61K	ENAMEL	ALNICO 5	VINTAGE	
TEXAS SPECIAL STRAT	5.94K	6.27K	6.27K	6.56K	ENAMEL	ALNICO 5	VINTAGE	CALIBRATED SET
FAT 50'S CUSTOM SHOP	6.26K	6.34K	6.48K	6.48K	FORMVAR	ALNICO 5	VINTAGE	CALIBRATED SET
69 STRAT CUSTOM SHOP	5.48K	5.48K	5.48K	5.48K	ENAMEL	ALNICO 5	VINTAGE	
FENDER NOISELESS	9.8K	9.8K	9.8K	9.8K	POLYSOL	ALNICO 2	CUSTOM	

NON HAND-WOUND TELE	NOMINAL DC RESISTANCE +/- 10%				WIRE	MAGNETS	BRIDGE PU STAGGER	NOTES
	NECK	MIDDLE	MID-RWRP	BRIDGE				
51 NOCASTER	7.9K			7.72K	ENAMEL	ALNICO 3	FLUSH	
63 TELECASTER	7.37K			6.59K	ENAMEL	ALNICO 2	VINTAGE	
67 TELECASTER	5.57K			5.99K	ENAMEL	ALNICO 5	VINTAGE	
TEXAS SPECIAL	9.02K			10.16K	ENAMEL	ALNICO 5	VINTAGE	
TWISTED TELE	5.95K			10K	ENAMEL	ALNICO 5	CUSTOM	
NOISELESS	12K			8.6K	ENAMEL	ALNICO 2	CUSTOM	

*For base model specifications see page 23

*Enamel wire pickups typically measure lower DCR vs. the same number of turns as FORMVAR



Fender
Custom Shop

1987

2017

30TH ANNIVERSARY

Model Shown: 1965 P-90 Stratocaster
Journeyman Relic Black, Built By Dale Wilson
P/N: 9721320607