

IBANEZ ARTIST ROSTER

ELECTRIC GUITAR ARTIST

Keith Azami Bad Acid Trip
 Tosin Abasi Animals As Leaders
 Dave Aguilera Star Academy
 Edouard Algaillon Avatar
 Simon Andersson Blackout
 Fabián Aravalés Carnifex
 Cory Arford Psyopus, Hank Williams III
 Chris Arp Timelord
 Matt Aub Hail of Bullets
 Paul Baayens Shadows Fall
 Matt Bachand Daniel Bage
 Daniel Bage Mutiny Within
 Rob Balducci
 Terry Balsamo Evanesence
 Way Barrier Destroy Destroy Destroy
 Rikk Beatty Rikk Beatty Band
 Steve Bello Steve Bello Band
 Justin Bender Into Eternity
 Jackson Bengé (hed) planet earth
 George Benson
 Sammy Black LOVEX
 Chris Broderick Megadeth
 Norman Brown
 Steve Brown Ignominious Incarceration
 JB Brubaker August Burns Red
 Gizz Butt The More I See
 Chris Camozzi Michael Bolton
 Noah Carpenter Skinless
 Dan Carter The Lucky Nine
 Cat Casino Deathstars
 Dino Cazares Fear Factory, Divine Heresy
 Curtis Chambers Franklin Bridge
 Sebastien Chaput Ion Dissonance
 Josh Childers The Showdown
 Audley Chisholm The Waiters
 Chad Crawford Scary Kids Scaring Kids
 Rob Daniels Jimmy Wayne Band
 Bjorn Dannov Abigail Williams
 Scott Danough
 Jim Davies Hyper, Victory Pill
 Isaac Delahaye Epica
 Brad Delson Linkin Park
 Mike Dewolf Taproot
 Dominic The Chronicals of Israfel
 Doug Doppler Doppler Inc.
 Fletcher Dragge Pennywise
 Niclas Engelin Engel
 Martyn Evans Trigger The Bloodshed
 Ryan Felton CHAOS DIVINE
 Jon Finn Jon Finn Group
 Tom Fischer Tryptykon
 David Fransson Division of Laura Lee
 Marty Friedman
 Justin Furstenfeld
 Fuzz
 Adriel Garcia Blue October
 Mark Gemini Thwaite Rolla, Deep Banana Blackout
 Rocky George City Sleeps
 Andreas Gerhard The Mission, Tricky
 Susan Gerl Fishbone
 Paul Gilbert Aloha from Hell
 Peter Goemaere God Dethroned
 Matt Good MR. BIG
 Cristi Gram From First to Last
 Gravy Phoenix
 Jon Greasley Mushroomhead
 Karl Groom Vega
 Ryan Gudmunds Threshold, Shadowland
 Trent Haf Dahl Carnifex
 Märten Hagström After the Burial
 Paul Hanson Meshuggah
 AJ Harvey Last Chance To Reason
 Simon Hawemann War From A Harlots Mouth
 Kasperi Heikkinen Amberian Dawn, Iconofear, Guardians of Mankind
 Oli Herbert All That Remains
 Gabriel Hidalgo Gabriel Hidalgo band, Six Magics
 Nick Hipa As I Lay Dying
 Hiro Head Phones President
 Pontus Hjelm Dead by April
 Dexter Holland The Offspring
 Steve Holt 36 Crazyfists
 Trond "Teeny" Holter Wig Wam
 Bernhard Horn Callejon
 Luke Hoskin Protest the Hero
 Bill Hudson Written in Blood
 Scott Hull Pig Destroyer
 Ihsahn Ihsahn, Emperor
 Nightmare Industries
 Andy Jackson Deathstars
 Brandon Jacobs Hot Rod Circuit
 Mark Jansen Mutiny Within
 Jonas Jämsby Epica
 Rob Johnson Avatar
 Steve Jones Magnitude 9
 Juan Juarez The Faceless
 Chris Kane Bonded By Blood
 Jesse Kative Eye of the Enemy
 Sean Kipe Emmure
 Steve Kirby Course of Nature
 Scary Kids Scaring Kids

Jon Kita Diecast
 Ryan Knight The Black Dahlia Murder
 Siméon Koch Eluveitie
 Kirk Kolaitis Diecast
 Eric Krasno Soulive
 Tony Laisto Hateform, Mors Principium Est
 John Lamacchia Candiria, A Family Plot
 Parker Lauzon Evans Blue
 Alex Lee Bonded By Blood
 Gary Lenaire
 Brian Leppke Bleeding Through
 Mike Lerner Behold...the Arctopus
 Eyal Levi Däath
 Herman Li DragonForce
 Jani Liimatainen Cain's Offering
 Ben Lionetti
 Logan Deadly Motor Vehicles
 Justin Lowe After The Burial
 Antoine Lussier Ion Dissonance
 Jari Mäenpää Wintersun
 Teemu Mäntysaari Wintersun
 Christian Münzner Obscura, Spawn of Possession
 Tony MacAlpine Planet X
 Mark MacDonald Austrian Death Machine
 Lee Malia Bring Me The Horizon
 Christofer Malmström Darkane
 Patrick Mameli Pestilence
 David Manley Jill Scott, Philosophik and Alo Brasil
 Andy Martin
 Buz McGrath
 James McIlroy Unearth
 Lee McKinney The Chaosent
 Patrick Meadows Born of Osiris
 Pat Metheny Gwen Stacy
 Larry Mitchell
 Mark Mitchell
 Atsushi Miyamoto Throwdown
 Monte Money Opus Dai
 Oskar Montelius Escape The Fate
 Sabaton
 Munky Demonoid
 Kristian Niemann Johan Niemann
 Per Nilsson Scar Symmetry
 Noodles The Offspring
 Pekka Oikkonen Stam'na
 Magnus Olsson
 Ben Orum All Shall Perish
 Jack Owen Deicide
 Dr. Z
 Rob Patterson Straight Line Stitch
 Pat Pattison Amberian Dawn
 Emil Pohjalainen The Eyes Of A Traitor
 Matthew Pugh Trigger The Bloodshed
 Rob Purnell Necrophagist
 Sami Raatikainen August Burns Red
 Brent Rambler Taproot
 Steve Richards All Shall Perish
 Jason Richardson Timelord
 Aaron Richert 3 Doors Down
 Matt Roberts The Mars Volta
 Omar Rodriguez-Lopez Patrick Rondat, Elegy
 Tim Roth Into Eternity
 Eric Sands
 Joe Satriani God Dethroned
 Henri Sattler
 John Scofield
 Jeremiah Scott Destroy Destroy Destroy
 Jake Scott Salt the Wound
 Arthur Seay House of Broken Promises
 Ryan Seppänen Tracedawn
 Justin Shekoski Linkin Park
 Mike Shinoda Killwitneydead, The Demonstration
 David Shoaf
 Dwight Sills
 Roger Sjunnesson Sonic Syndicate
 Terji Skibenaes Tyr
 Waldemar Sorychta Enemy of the Sun, ReVamp
 Barry Stock Salt the Wound
 Nita Strauss Kill Slowly, As Blood Runs Black
 Vince Stropki The Wound
 Muhammed Sulçmez Necrophagist
 Rikard Sundén Sabaton
 Marcus Suneson Engel
 Ken Susi Unearth
 Tommy Svela Purified in blood
 Vlad Tanaskovic Evans Blue
 Jaime Teissere Droid
 Seth Thacker Straight Line Stitch
 Bobby Thompson Job For A Cowboy
 Mick Thomson Slipknot
 Fredrik Thordendal Meshuggah
 Andy Timmons
 Sam Totman DragonForce
 Dave Ulrich U.Nam
 Patrick Uterwijk Pestilence
 Steve Vai

www.ibanez.com

1726 Winchester Road, Bensalem, PA 19020 · 327 Broadway, Idaho Falls, ID 83402 · \$5.00 in U.S.A. · ©2010 Printed in Japan (40m) DEC09754 (U)

Ibanez

Electric Guitars, Electric Bases, Amplifiers, Effects & Accessories 2010

Elias Viljanen Sonata Arctica
 Bob Weir RatDog, The Dead
 Brian "Head" Welch The Eyes Of A Traitor
 Steve Whitworth Diecast
 Jussi Wickström Turisas
BASS ARTIST
 Sean Andrews Redemption
 Karin Axelsson Sonic Syndicate
 Chuck Bailey Kid Deposit Triumph
 Chris Ball Ignominious Incarceration
 Stephane Barbe Kataklysm
 Glen Benton Deicide, Vital Remains
 Jett Beres Sister Hazel
 Adam Blackstone Kanye West, Janet Jackson
 Troy Bleich Into Eternity
 Dennis Bradley Beneath the Massacre
 Nelson Braxton The Braxton Brothers, Michael Bolton
 Marc Brownstein The Disco Biscuits
 Stephen Bruner Suicidal Tendencies, Erykah Badu
 Jason C LOVEX
 Fred Calderon Carnifex
 Tony Choy Pestilence, Atheist, Area 305
 Marco Coti Zelati Lacuna Coil
 Sharlee D'Angelo Arch Enemy
 Mike D'Antonio Killswitch Engage
 David Darocha Born of Osiris
 Dustin Davidson August Burns Red
 Mark Davis Emmure
 Skinny Disco Deathstars
 Ross Dolan Chaosant
 Anthony "Woodchuck" Durban Immolation
 El Pus
 Korn
 Lee Foral After the Burial
 Josh Gilbert As I Lay Dying
 Paul Gray Slipknot
 Roland Guerin Marcus Roberts Trio, Solo Artist
 Filip Hantusch War From A Harlots Mouth
 Henna Stalingrad Cowgirls
 Alex Hernandez Ascension
 Peter Iwers In Flames
 Anders Iwers Tiamat
 Andrew Jacobs Mutiny Within
 Tru James Stone Mecca
 Bernd "Flash" Jansen Wig Wam
 Sven Janssens Aborted
 Percy Jones Evergrey
 Jari Kainulainen
 Carol Kaye
 Joe Keyser Skinless
 Jukka Koskinen Wintersun, Norther, Cain's Offering
 Steinar Krokmo Pagan's Mind
 Tommi Kuri Amberian Dawn
 Andreas Lagios Rotting Christ
 Fredrik Larsson HammerFall
 John "Slo" Maggard Unearth
 Mike Murphy Haste The Day
 Narumi Head Phones President
 OX LORDI
 Marko Paasikoski Sonata Arctica
 Matt Pantelis Veil Of Maya
 Joe Payne Divine Heresy
 Rufus Philpot Planet X, Down to the Bone
 Joe Pitter Evans Blue
 Dave Purnell Trigger The Bloodshed
 Paul Romanko Shadows Fall
 Scott Root Dirlfedd
 Jeanne Sagan All That Remains
 Brent Schindler Gwen Stacy
 Caleb Schneider Bad Acid Trip
 Matt Snell Five Finger Death Punch
 Aurora Steffens The Black Sheep
 Frank Stummvoll Krypteria
 Joni Suodenjärvi Hateform
 Gunnar H. Thomsen Tyr
 Caisa Troedsson Galaisa
 Gerald Veasley
 Tom Verryken Poison My Blood
 Mugurel Vrabete Holograf
 Paul Waudby The Eyes Of A Traitor
 Marcus Wesslén Dead by April
 Jason White Straight Line Stitch
 Mick Whitney 36 Crazyfists
 Gary Willis Solo Artist, Triphasic, Slaughterhouse 3
 Ryan Wombacher Bleeding Through
 Mark Young (hed) planet earth
 Henke Zinger God Dethroned
ELECTRONICS ARTIST
 Doug Aldrich Whitesnake, Dio
 Michael Amott Arch Enemy
 John Bohlinger Nashville Star, Session
 Dino Cazares Divine Heresy, Fear Factory
 Adam Dutkiewicz Killswitch Engage
 Audley Freed
 Jason Hook Five Finger Death Punch
 Matt Scannell Vertical Horizon
 Mike Scott Justin Timberlake, Prince, Session
 Alex Skolnick Testament, Trans-Siberian Orchestra
 Joel Stroetzel Killswitch Engage
 TAKE-C SHAKALABBITS

2010

Electric Guitars, Electric Bases, Amplifiers, Effects & Accessories



A great live sound is the result of hard work...from the decisions that go into developing and refining it, all the way to the experience it takes to successfully reproduce it night after night. It's also a result of choosing the right gear...gear that sounds the way you need it to—consistently, dependably, affordably.

Here at Ibanez, we understand what it takes to build great sounding gear. We work closely with the artists that use our instruments, amps and effects, every day, to make sure we stay on top of the changing needs of modern musicians. We see it as our job to produce relevant, affordable solutions for every application.

Electric Guitars

Allow us to welcome you to our 2010 catalog and invite you to take a look around. As you flip through it's pages, you may be surprised at how many of your favorite artists are using Ibanez. Oh, and while you're here, be sure to check out the RGA series electric guitars. With active pickups, active eq, and a new arched top design, these axes are a pleasure to play and offer nearly unlimited tonal possibilities.

Seeking something really heavy? The RGD series is literally made for you. These guitars, including the 7-string model, are actually designed for down-tuning. The days of floppy strings are officially over. Let a new era of speed, accuracy, and sonic brutality begin!

Remember, great tone starts with great gear. Shape yours with Ibanez!

CONTENTS

2-3	Intro	62	AG/AGS
4-5	JEM/UV	63-64	AS
6-12	RG Prestige	65	AM/AMF
13	Artists	66	Artists
14	MTM	67	Bass Intro
15	APEX	68-70	SR Prestige
16-18	RG Trem	71	GWB
19	AT/PGM	72-73	SRT
20-21	RG Fixed	74-75	SRA
22	GRG/GRX	76	K5
23	Mikro	77	PIB
24	MBM	78-85	SR
25	RGA Prestige	86	SRX
26-28	RGA	87	MDB/PRB
29	GRGA	88	BTB
30-31	RGD Prestige	89	ICB/SDB
30	RGD	90	ATK
32-33	JS	91	PGB
34	EGEN/STM	92	ARTB/JTKB
35	S Prestige	93	Artcore Basses
36-37	S	94-96	GSR
38	ICT/DTT	97	Mikro/GARTB
39	DN	98	Bass Jumpstart
40-41	XPT	99	Electronics Intro
42	AR Prestige	100	TBX
43-47	ART/ARX	101	MIMX
48	GART	102-103	Promethean
49	FR Prestige	104	SWX
50	SV Prestige	105-106	Effect Pedals
51	SA/GSA	107	Tone-Lok
52	ORM/NDM	108-109	Cables/Tuners
53	Jet King		Cases/Gig Bags/
54	Guitar Jumpstart	110-111	Picks/Straps
55	Hollow Body Intro	112	Pickup Specs
56	GB		Frequency
57	PM/JSM	113	Response Curves
58	AF/AS Custom	114-115	Switching Systems
59	AK	115	Neck Dimensions
60	AF	116-117	Tremolos
61	AFS	118-119	Finishes



STEVE VAI SIGNATURE MODELS

Steve Vai is one of the few guitarists universally acknowledged as one who has changed the way musicians think about what a guitar can really do. His signature Ibanez guitars are no different: Iconic, Sublime, Awe-Inspiring, Outrageous. The Ibanez JEM Series models are trailblazers in a world of imitators – there's nothing like them.

H-S-H (5WAY)

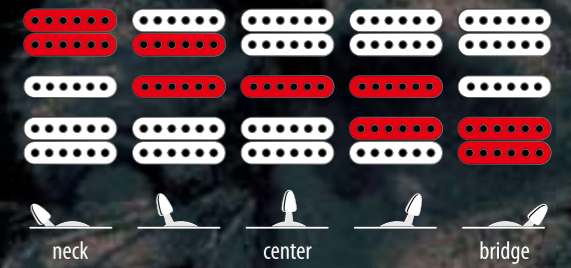

SPLIT-5 PICKUP SWITCHING SYSTEM

Vai's choice of specific DiMarzio pickups for each model combined with Ibanez Split-5 wiring provide incredible tonal versatility.

JEM7V WH

- 5pc JEM Maple/Walnut neck *Prestige*
- Alder body
- W/6105 frets
- Edge bridge
- DiMarzio® Evolution® (H) neck pu
- DiMarzio® Evolution® (S) mid pu
- DiMarzio® Evolution® (H) bridge pu
- Hardware color : Gold
- Scale : 648mm/25.5"
- Color : WH (White)



JEM77V BK

- 5pc JEM Maple/Walnut neck *Prestige*
- Basswood body
- W/6105 frets
- Edge bridge
- DiMarzio® Breed™ (H) neck pu
- DiMarzio® Breed™ (S) mid pu
- DiMarzio® Breed™ (H) bridge pu
- Hardware color : Chrome
- Scale : 648mm/25.5"
- Color : BK (Black)



JEM505 BK

- 5pc JEM Maple/Walnut neck *Prestige*
- Basswood body
- W/6105 frets
- Edge bridge
- V7 (H) neck pu
- S1 (S) mid pu
- V8 (H) bridge pu
- Hardware color : Cosmo Black
- Scale : 648mm/25.5"
- Colors : BK (Black)
WH (White)



JEM505 WH

- 5pc JEM Maple/Walnut neck *Prestige*
- Basswood body
- W/6105 frets
- Edge bridge
- V7 (H) neck pu
- S1 (S) mid pu
- V8 (H) bridge pu
- Hardware color : Cosmo Black
- Scale : 648mm/25.5"
- Colors : BK (Black)
WH (White)



UV777 BK

- 5pc UV Maple/Wenge neck *Prestige*
- Basswood body
- Jumbo frets
- Lo-Pro Edge 7 bridge
- DiMarzio® Blaze® (H) neck pu
- DiMarzio® Blaze® (S) mid pu
- DiMarzio® Blaze® (H) bridge pu
- Hardware color : Chrome
- Scale : 648mm/25.5"
- Color : BK (Black)



RG Prestige

CRAFTED BY JAPAN'S FINEST LUTHIERS

At Ibanez we believe that the instrument should never overshadow the artist. Our aim is to provide the best instruments for producing music, period. Music is created by musicians, not the instruments, and instruments should support and allow musicians to unleash and extend their imagination. With this concept in mind we developed the Ibanez Prestige.

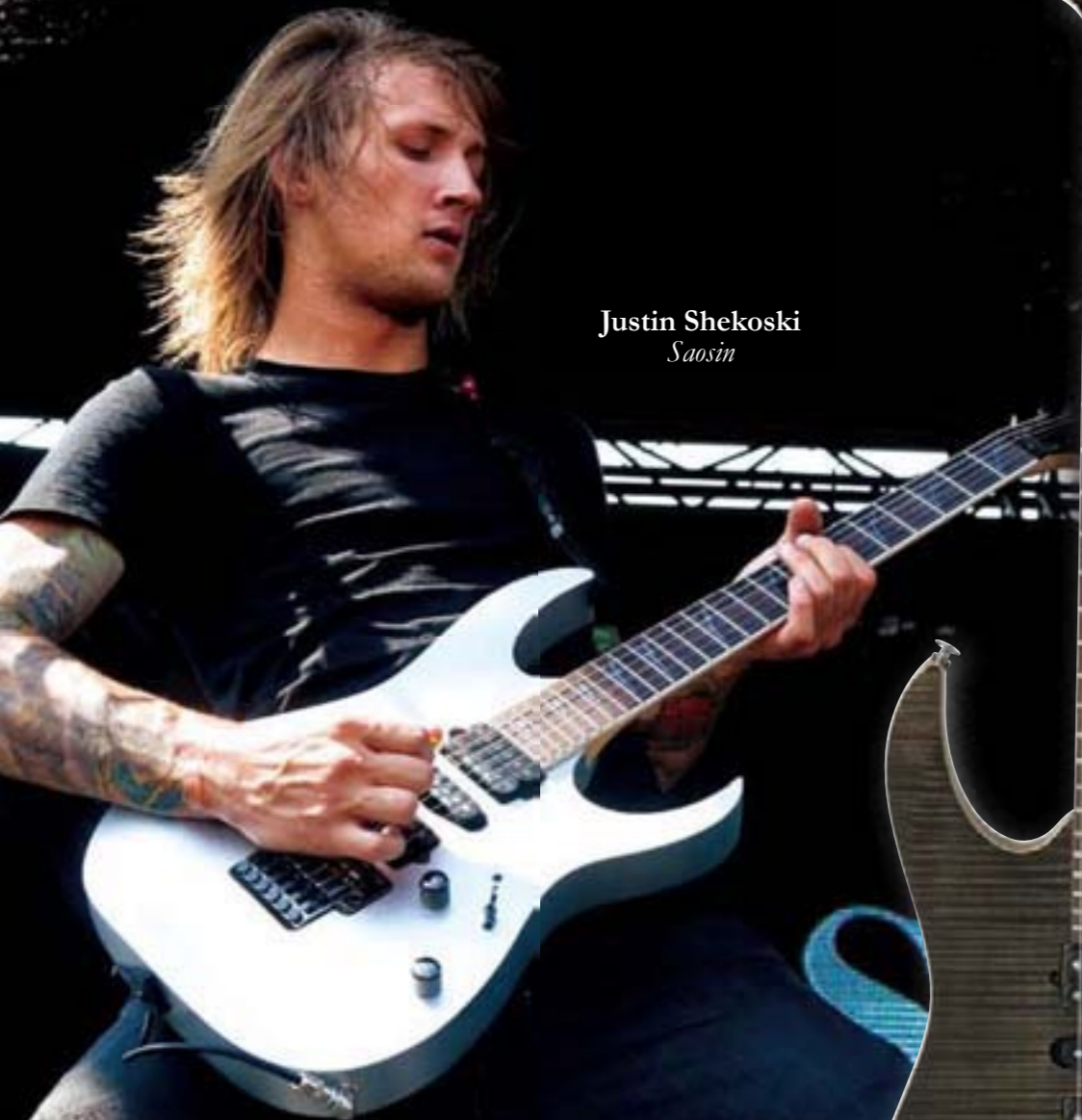

Justin Shekoski
Saosin



RG4570Z HBK

- 5pc Ultra HP Maple/Walnut neck *Prestige* w/KTS™ TITANIUM Reinforcement
- Flamed Maple top/Mahogany body
- Jumbo frets
- Edge-Zero bridge w/ZPS3
- DiMarzio® Air Norton™ (H) neck pu
- DiMarzio® True Velvet™ (S) mid pu
- DiMarzio® Tone Zone® (H) bridge pu
- Hardware color : Cosmo Black
- Scale : 648mm/25.5"
- Color : HBK (Himalayan Black)



RG3770Z CAB

- 5pc Super Wizard HP Maple/Walnut neck *Prestige* w/KTS™ TITANIUM Reinforcement
- Basswood body
- Jumbo frets
- Edge-Zero bridge w/ZPS3
- DiMarzio® Air Norton™ (H) neck pu
- DiMarzio® True Velvet™ (S) mid pu
- DiMarzio® Tone Zone® (H) bridge pu
- Hardware color : Cosmo Black
- Scale : 648mm/25.5"
- Colors : CAB (Caribbean Blue Lagoon) DSP (Dark Space)



RG3770Z DSP

- 5pc Super Wizard HP Maple/Walnut neck *Prestige* w/KTS™ TITANIUM Reinforcement
- Basswood body
- Jumbo frets
- Edge-Zero bridge w/ZPS3
- DiMarzio® Air Norton™ (H) neck pu
- DiMarzio® True Velvet™ (S) mid pu
- DiMarzio® Tone Zone® (H) bridge pu
- Hardware color : Cosmo Black
- Scale : 648mm/25.5"
- Colors : CAB (Caribbean Blue Lagoon) DSP (Dark Space)

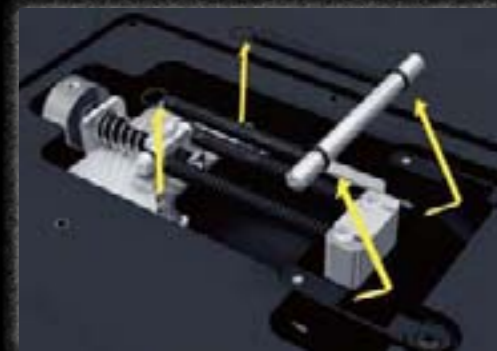

ZPS3 Zero Point System

The ZPS3 spring system represents the next phase of Zero Point evolution. The new ZPS3 is made of lightweight and durable Duralumin, reducing overall weight as well as cavity size on the guitar body's back. This revolutionary system enables switching between floating and non-floating tremolo set-ups.

SPLIT-5 PICKUP SWITCHING SYSTEM H-S-H (5WAY)

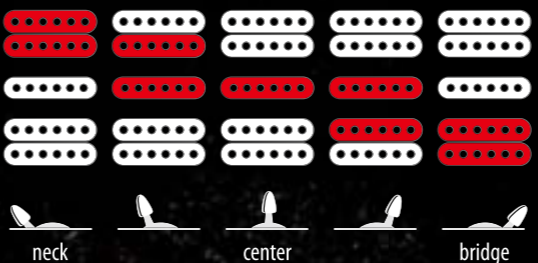

RG3570Z LB

- 5pc Super Wizard HP Maple/Walnut neck *Prestige* w/KTS™ TITANIUM Reinforcement
- Basswood body
- Jumbo frets
- Edge-Zero bridge w/ZPS3
- DiMarzio® Air Norton™ (H) neck pu
- DiMarzio® True Velvet™ (S) mid pu
- DiMarzio® Tone Zone® (H) bridge pu
- Hardware color : Cosmo Black
- Scale : 648mm/25.5"
- Colors : LB (Laser Blue) CA (Candy Apple)



RG3570Z CA

- 5pc Super Wizard HP Maple/Walnut neck *Prestige* w/KTS™ TITANIUM Reinforcement
- Basswood body
- Jumbo frets
- Edge-Zero bridge w/ZPS3
- DiMarzio® Air Norton™ (H) neck pu
- DiMarzio® True Velvet™ (S) mid pu
- DiMarzio® Tone Zone® (H) bridge pu
- Hardware color : Cosmo Black
- Scale : 648mm/25.5"
- Colors : LB (Laser Blue) CA (Candy Apple)



ULTRA HP NECK

Ball mill, digitized compound radius neck grip offer hand crafted neck feelings. Prestige Ultra neck is for the expert guitarists who plays wide variations of music.

*Digitized compound radius neck grip also applies to JS series/AT series



RG3550MZ GW

- 5pc Super Wizard HP Maple/Walnut neck *Prestige* w/KTS™ TITANIUM Reinforcement
- Basswood body
- Jumbo frets
- Edge-Zero bridge w/ZPS3
- DiMarzio® Air Norton™ (H) neck pu
- DiMarzio® True Velvet™ (S) mid pu
- DiMarzio® Tone Zone® (H) bridge pu
- Hardware color : Cosmo Black
- Scale : 648mm/25.5"
- Colors : GK (Galaxy Black)
- GW (Galaxy White)
- DY (Desert Sun Yellow)
- ROM (Roadster Orange Metallic)



RG3550MZ ROM

- 5pc Super Wizard HP Maple/Walnut neck *Prestige* w/KTS™ TITANIUM Reinforcement
- Basswood body
- Jumbo frets
- Edge-Zero bridge w/ZPS3
- DiMarzio® Air Norton™ (H) neck pu
- DiMarzio® True Velvet™ (S) mid pu
- DiMarzio® Tone Zone® (H) bridge pu
- Hardware color : Cosmo Black
- Scale : 648mm/25.5"
- Colors : GK (Galaxy Black)
- GW (Galaxy White)
- DY (Desert Sun Yellow)
- ROM (Roadster Orange Metallic)



RG3550MZ GK

- 5pc Super Wizard HP Maple/Walnut neck *Prestige* w/KTS™ TITANIUM Reinforcement
- Basswood body
- Jumbo frets
- Edge-Zero bridge w/ZPS3
- DiMarzio® Air Norton™ (H) neck pu
- DiMarzio® True Velvet™ (S) mid pu
- DiMarzio® Tone Zone® (H) bridge pu
- Hardware color : Cosmo Black
- Scale : 648mm/25.5"
- Colors : GK (Galaxy Black)
- GW (Galaxy White)
- DY (Desert Sun Yellow)
- ROM (Roadster Orange Metallic)



RG3550MZ DY

- 5pc Super Wizard HP Maple/Walnut neck *Prestige* w/KTS™ TITANIUM Reinforcement
- Basswood body
- Jumbo frets
- Edge-Zero bridge w/ZPS3
- DiMarzio® Air Norton™ (H) neck pu
- DiMarzio® True Velvet™ (S) mid pu
- DiMarzio® Tone Zone® (H) bridge pu
- Hardware color : Cosmo Black
- Scale : 648mm/25.5"
- Colors : GK (Galaxy Black)
- GW (Galaxy White)
- DY (Desert Sun Yellow)
- ROM (Roadster Orange Metallic)



RG1570 LMR

- 5pc Wizard HP Maple/Walnut neck *Prestige*
- Basswood body
- Jumbo frets
- Edge-Zero bridge w/ZPS3
- V7 (H) neck pu
- S1 (S) mid pu
- V8 (H) bridge pu
- Hardware color : Cosmo Black
- Scale : 648mm/25.5"
- Colors : BK (Black)
- CA (Candy Apple)
- LMR (Liquid Metal Red)



RG1570 CA

- 5pc Wizard HP Maple/Walnut neck *Prestige*
- Basswood body
- Jumbo frets
- Edge-Zero bridge w/ZPS3
- V7 (H) neck pu
- S1 (S) mid pu
- V8 (H) bridge pu
- Hardware color : Cosmo Black
- Scale : 648mm/25.5"
- Colors : BK (Black)
- CA (Candy Apple)
- LMR (Liquid Metal Red)



RG1570 BK

- 5pc Wizard HP Maple/Walnut neck *Prestige*
- Basswood body
- Jumbo frets
- Edge-Zero bridge w/ZPS3
- V7 (H) neck pu
- S1 (S) mid pu
- V8 (H) bridge pu
- Hardware color : Cosmo Black
- Scale : 648mm/25.5"
- Colors : BK (Black)
- CA (Candy Apple)
- LMR (Liquid Metal Red)



Dexter Holland
The Offspring



VINTAGE 7 PICKUP

Tight, but bright. Very dynamic for chording and rhythm.

SINGLE 1 PICKUP

Traditional-sounding yet high output single coil with Alnico-5 polepieces for even string output. Designed to work with humbuckers in the split position.

VINTAGE 8 PICKUP

Warm yet articulate lead pickup with enhanced overtones. Good harmonics without excessive brightness.

Super Wizard HP neck (HP=high performance)

More comfortable neck feel, smoother neck shape, while retaining same thin profile as before – 17.0mm (at 1st fret).

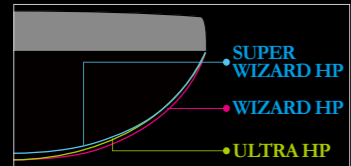

DIMARZIO® AIR NORTON™ PICKUP

The tone is deep and warm, but not muddy. Hot, but not distorted. It's even got cool harmonics, which are really unusual for a neck humbucker.

DIMARZIO® TRUE VELVET™ PICKUP

A vintage-style single-coil pickup that's clean and bright, but designed to still sound sweet when picking above the 12th fret. Coil is tuned to a frequency range that's bright but not thin.

DIMARZIO® TONE ZONE® PICKUP

Hot enough to qualify as a high-output pickup, but has a wider dynamic range – hard picking will produce a lot of power, and softer picking will be much cleaner and quieter.





RG1550M WHP

- 5pc Wizard HP Maple/Walnut neck *Prestige*
- Basswood body
- Jumbo frets
- Edge-Zero bridge w/ZPS3
- V7 (H) neck pu
- S1 (S) mid pu
- V8 (H) bridge pu
- Hardware color : Cosmo Black
- Scale : 648mm/25.5"
- Colors : PBL (Phantom Blue)
- PPN (Poisoned Pumpkin)
- WHP (White Plaster)



RG1550M PPN

- 5pc Wizard HP Maple/Walnut neck *Prestige*
- Basswood body
- Jumbo frets
- Edge-Zero bridge w/ZPS3
- V7 (H) neck pu
- S1 (S) mid pu
- V8 (H) bridge pu
- Hardware color : Cosmo Black
- Scale : 648mm/25.5"
- Colors : PBL (Phantom Blue)
- PPN (Poisoned Pumpkin)
- WHP (White Plaster)



Ryan Knight
The Black Dahlia Murder



RG1550M PBL

- 5pc Wizard HP Maple/Walnut neck *Prestige*
- Basswood body
- Jumbo frets
- Edge-Zero bridge w/ZPS3
- V7 (H) neck pu
- S1 (S) mid pu
- V8 (H) bridge pu
- Hardware color : Cosmo Black
- Scale : 648mm/25.5"
- Colors : PBL (Phantom Blue)
- PPN (Poisoned Pumpkin)
- WHP (White Plaster)



RG1550M BKL

- 5pc Wizard HP Maple/Walnut neck *Prestige*
- Basswood body
- Jumbo frets
- Edge-Pro bridge
- V7 (H) neck pu
- S1 (S) mid pu
- V8 (H) bridge pu
- Hardware color : Cosmo Black
- Scale : 648mm/25.5"
- Color : BK (Black)

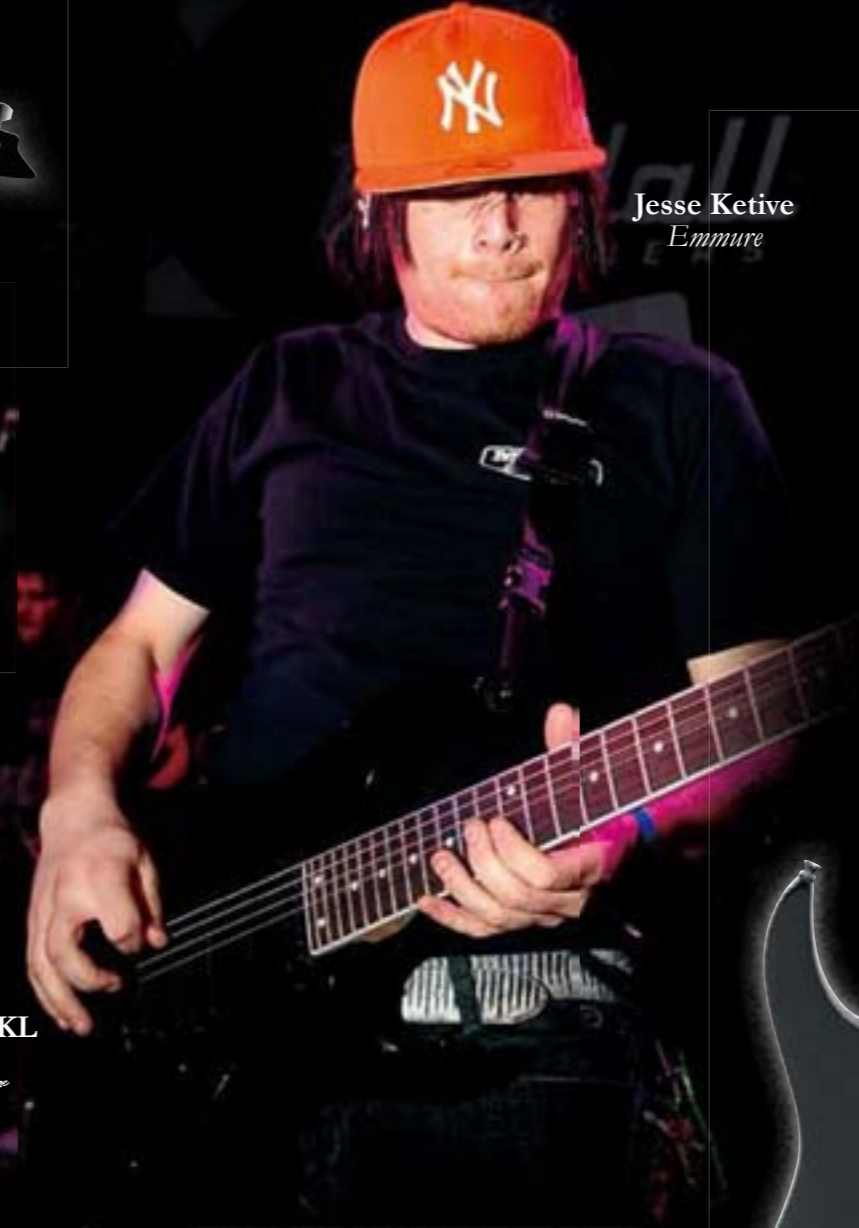

Jesse Ketive
Emmure



RG1451 NC

- 5pc Wizard HP Maple/Walnut neck *Prestige*
- Basswood body
- Jumbo frets
- Tight-End bridge
- V6F (H) neck pu
- RTS (S) mid pu
- V6F2 (H) bridge pu
- Hardware color : Cosmo Black
- Scale : 648mm/25.5"
- Colors : AG (Aluminum Gray)
- NC (Night Crow)



RG1451 AG

- 5pc Wizard HP Maple/Walnut neck *Prestige*
- Basswood body
- Jumbo frets
- Tight-End bridge
- V6F (H) neck pu
- RTS (S) mid pu
- V6F2 (H) bridge pu
- Hardware color : Cosmo Black
- Scale : 648mm/25.5"
- Colors : AG (Aluminum Gray)
- NC (Night Crow)



TIGHT-END BRIDGE

The Tight-End bridge integrates every aspect of the bridge design in rigidness and accuracy. Saddles are firmly locked onto the base plate for maximum string vibration, and remain perfectly linear during intonation adjustment for the most accurate set up. The saddle height can be adjusted individually by one screw. Also, the top side of the bridge is smooth finished. So if you play hard, the Tight-End bridge will forgive you and your hands.

COLLET KNOB

Designed for great looks and engineered to avoid the risk of coming off while you're playing. The non-slip functionality gives this collet knob accurate axis rotation and control for any player.





Mårten Hagström
Meshuggah

Fredrik Thordendal
Meshuggah



FX EDGE III-8 BRIDGE

RG2228's Fixed Edge III-8 bridge combines fixed bridge sustain and double-locking stability.

RG2228 GK

- 5pc Ultra-8 Maple/Wenge neck *Prestige* w/KTS™ TITANIUM Reinforcement
- Basswood body
- Jumbo frets
- FX EDGE III-8 bridge
- EMG® 808 (H) neck pu
- EMG® 808 (H) bridge pu
- Hardware color : Black
- Scale : 685.8mm/27"
- Factory tuning:
1D#, 2A#, 3F#, 4C#, 5G#, 6D#, 7A#, 8F
- String gauge:
.009/ .011/ .016/ .024/ .032/ .042/ .054/ .065
- Color : GK (Galaxy Black)

RG1527M GW

- 5pc Wizard-7 Maple /Wenge neck *Prestige*
- Basswood body
- Jumbo frets
- Edge-Zero 7 bridge w/ZPS3
- V77 (H) neck pu
- V87 (H) bridge pu
- Hardware color : Cosmo Black
- Scale : 648mm/25.5"
- Color : GW (Galaxy White)

RG1527 RB

- 5pc Wizard-7 Maple /Wenge neck *Prestige*
- Basswood body
- Jumbo frets
- Edge-Zero 7 bridge w/ZPS3
- V77 (H) neck pu
- V87 (H) bridge pu
- Hardware color : Cosmo Black
- Scale : 648mm/25.5"
- Color : RB (Royal Blue)

**RG(H-H) pickup switching system
H-H 5WAY (RG1527M/RG1527)**



Humbucker is parallel connected.

Keith Aazami Bad Acid Trip	Tosin Abasi Animals As Leaders	Sean Andrews Redemption	Chris Arp Psyopus, Hank Williams III	Daniel Bage Mutiny Within
Way Barrier Destroy Destroy Destroy	Justin Bender Into Eternity	Jackson Bengtson (hed) planet earth	Jett Beres Sister Hazel	Troy Bleich Into Eternity
Dennis Bradley Beneath the Massacre	Steve Bruner Suicidal Tendencies, Erykah Badu	Noah Carpenter Skinless	Tony Choy Pestilence, Atheist, Area 305	David Darocha Born of Osiris
Jim Davies Hyper, Victory Pill	Mike Dewolf Taproot	Ross Dolan Immolation	Fletcher Dragge Pennywise	Tom Fischer Tryptykon
Fuzz Rolla, Deep Banana Blackout	Adriel Garcia City Sleeps	Rocky George Fishbone	Gravy Mushroomhead	Brian "Head" Welch
Steve Holt 36 Crazyfists	Scott Hull Pig Destroyer	Andrew Jacobs Mutiny Within	Brandon Jacobs Mutiny Within	Percy Jones
Steve Jones The Faceless	Jari Kainulainen Evergrey	Joe Keyser Skinless	Jon Kita Diecast	Siméon Koch Eluveitie

SLIPKNOT
Mick Thomson
 SIGNATURE
 MODELS

photo by Kevin Estrada

That tightness around your throat. Getting harder to breathe. Slipknot guitarist Mick Thomson's signature models have a way of doing that. With their high-output Seymour Duncan® Blackouts™ EMTY™ active pickups and Edge FX bridges, these low-tuned axes churn out demonic metal so unholy, it might make some people uncomfortable. In a good way.



MTM1 BR

- 5pc Wizard II Maple/Walnut neck-thru w/KTS™ TITANIUM Reinforcement
- Mahogany wing body
- Jumbo frets
- FX Lo-Pro Edge bridge
- Seymour Duncan® Blackouts™ EMTY™ (H) neck pu
- Seymour Duncan® Blackouts™ EMTY™ (H) bridge pu
- Hardware color: Black
- Scale: 648mm/25.5"
- Factory tuning: 1C#, 2G#, 3E, 4B, 5F#, 6B
- String gauge: .011/.014/.018/.028/.038/.049
- Color: BR (Blood Red)



MTM2 BK

- 5pc Wizard II Maple/Walnut neck
- Mahogany body
- Jumbo frets
- FX Edge III bridge
- Duncan® HB-105MT (H) neck pu
- Duncan® HB-105MT (H) bridge pu
- Hardware color: Black
- Scale: 648mm/25.5"
- Factory tuning: 1C#, 2G#, 3E, 4B, 5F#, 6B
- String gauge: .011/.014/.018/.028/.038/.049
- Colors: BK (Black)

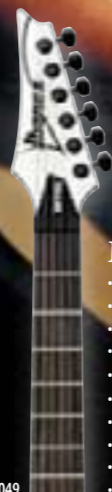

MTM2 WH

- 5pc Wizard II Maple/Walnut neck
- Mahogany body
- Jumbo frets
- FX Edge III bridge
- Duncan® HB-105MT (H) neck pu
- Duncan® HB-105MT (H) bridge pu
- Hardware color: Black
- Scale: 648mm/25.5"
- Factory tuning: 1C#, 2G#, 3E, 4B, 5F#, 6B
- String gauge: .011/.014/.018/.028/.038/.049
- Colors: BK (Black)



PAINTED MTM2 NECK

The MTM2 comes with a matching color neck back.

KORN
Munky
 SIGNATURE MODELS

With Korn, Munky took a 7-seven string shred machine and turned it into a low-end bone crusher. His signature beast, The APEX, despite its lofty name, represents the darkness lurking at the bottom of the deepest well and harnesses the power at the lowest point of the pendulum.

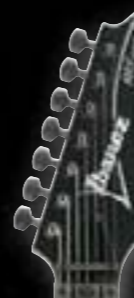
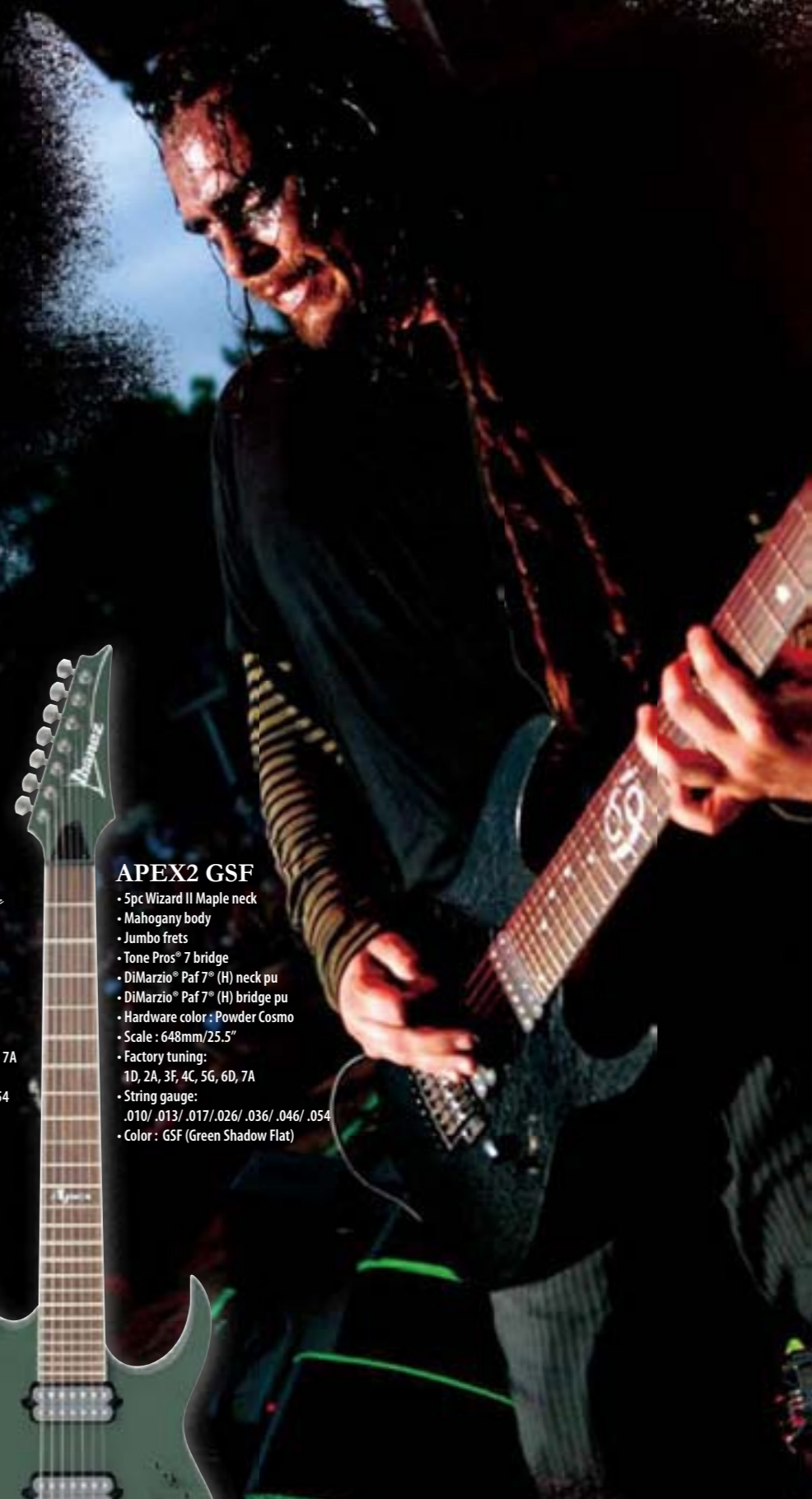

APEX1 BBK

- 5pc APEX Maple/Wenge neck *Prestige*
- Mahogany body
- Jumbo frets
- Lo-Pro Edge 7 bridge w/U-bar
- DiMarzio® Paf 7® (H) neck pu
- DiMarzio® Paf 7® (H) bridge pu
- Hardware color: Powder Cosmo
- Scale: 648mm/25.5"
- Factory tuning: 1D, 2A, 3F, 4C, 5G, 6D, 7A
- String gauge: .010/.013/.017/.026/.036/.046/.054
- Color: BBK (Biker's Black)



APEX2 GSF

- 5pc Wizard II Maple neck
- Mahogany body
- Jumbo frets
- Tone Pros® 7 bridge
- DiMarzio® Paf 7® (H) neck pu
- DiMarzio® Paf 7® (H) bridge pu
- Hardware color: Powder Cosmo
- Scale: 648mm/25.5"
- Factory tuning: 1D, 2A, 3F, 4C, 5G, 6D, 7A
- String gauge: .010/.013/.017/.026/.036/.046/.054
- Color: GSF (Green Shadow Flat)



RG TREMOLO

RG Tremolo models stand up to the most abusive whammy bar users around, while still maintaining perfect tuning stability. Lightning fast fretboard work is no problem with the Wizard neck, flat fingerboard and jumbo frets.



RGT42DXFM TGB

- 5pc Wizard II Maple/Walnut neck-thru w/KTS™ TITANIUM Reinforcement
- Flamed Maple top/Mahogany wing body
- Jumbo frets
- Edge III bridge
- INF1 (H) neck pu
- INF2 (H) bridge pu
- Hardware color : Powdered Cosmo Black
- Scale : 648mm/25.5"
- Color : TGB (Transparent Gray Burst)



THRU-NECK CONSTRUCTION

Back view of the RGT42DXFM TGB's 5-piece maple/walnut Wizard II thru-neck.



RG420FB NBF

- 3pc Wizard II Maple neck
- Figured Bubinga top/Mahogany body
- Jumbo frets
- Edge III bridge
- INF1 (H) neck pu
- INF2 (H) bridge pu
- Hardware color : Cosmo Black
- Scale : 648mm/25.5"
- Color : NBF (Natural Brown Burst Flat)

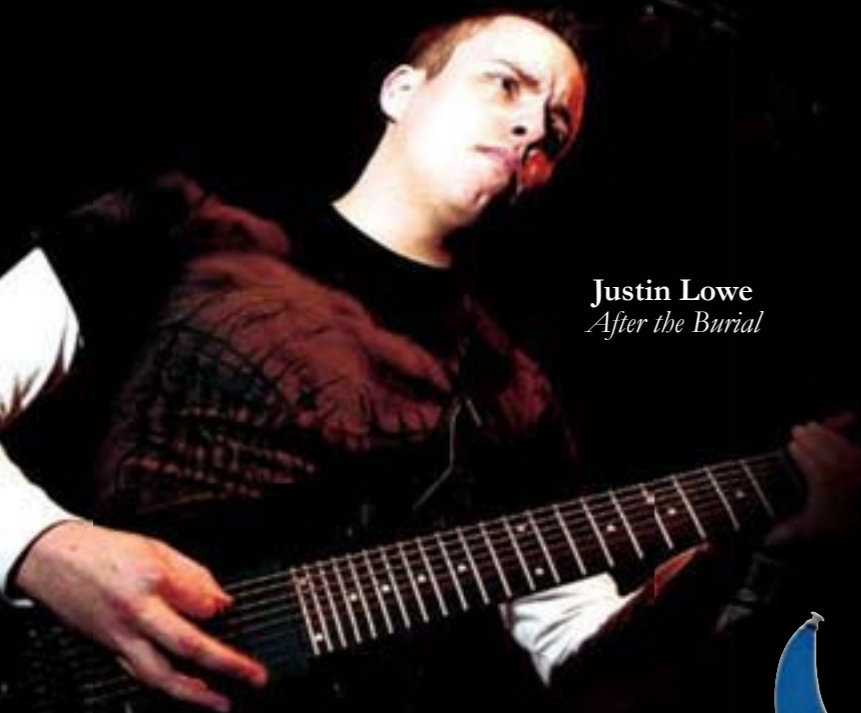

Justin Lowe
After the Burial



RG470AH BBL

- 3pc Wizard II Maple neck
- Ash body
- Jumbo frets
- Edge III bridge
- INF1 (H) neck pu
- INF51 (S) mid pu
- INF2 (H) bridge pu
- Hardware color : Cosmo Black
- Scale : 648mm/25.5"
- Colors : BBL (Bright Blue)
- NTF (Natural Flat)



RG470AH NTF

- 3pc Wizard II Maple neck
- Ash body
- Jumbo frets
- Edge III bridge
- INF1 (H) neck pu
- INF51 (S) mid pu
- INF2 (H) bridge pu
- Hardware color : Cosmo Black
- Scale : 648mm/25.5"
- Colors : BBL (Bright Blue)
- NTF (Natural Flat)



LIGHT ASH BODY

RG470AH NTF's light ash body brings more punch to the mid-range tones.

RG TREMOLO

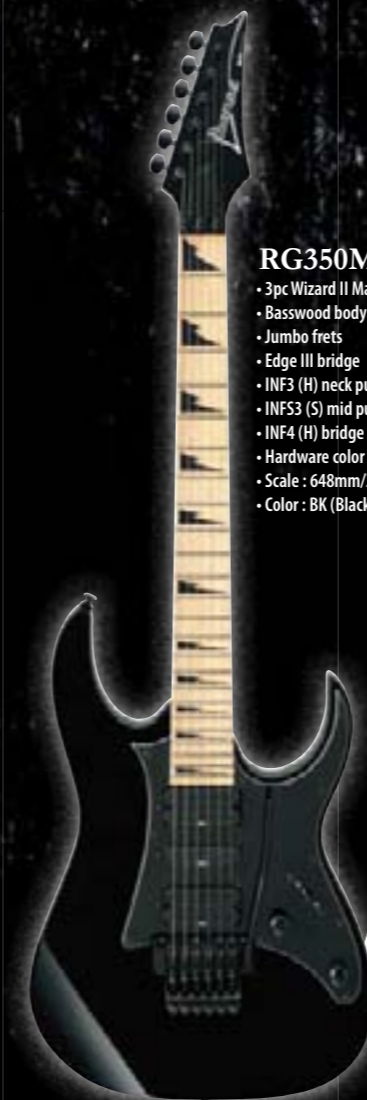

RG350MDX BK

- 3pc Wizard II Maple neck
- Basswood body
- Jumbo frets
- Edge III bridge
- INF3 (H) neck pu
- INF53 (S) mid pu
- INF4 (H) bridge pu
- Hardware color : Black
- Scale : 648mm/25.5"
- Color : BK (Black)



RG350DX WH

- 3pc Wizard II Maple neck
- Basswood body
- Jumbo frets
- Edge III bridge
- INF3 (H) neck pu
- INF53 (S) mid pu
- INF4 (H) bridge pu
- Hardware color : Black
- Scale : 648mm/25.5"
- Color : WH (White)

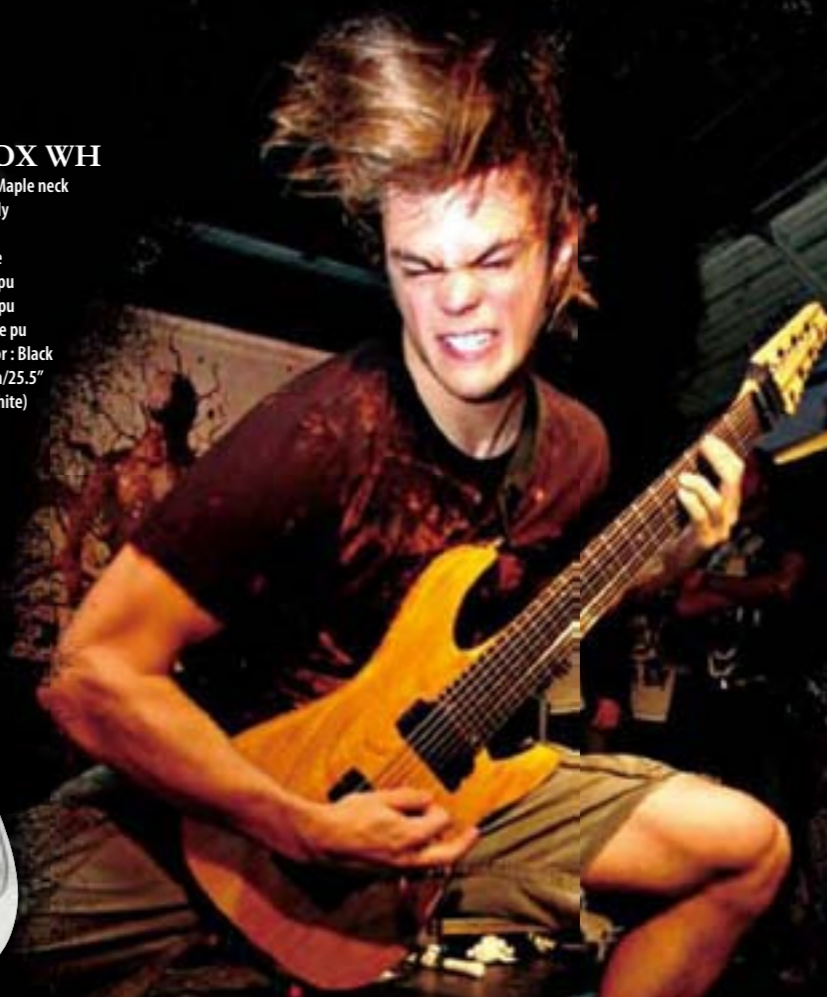

Trent Hafdahl
After the Burial



RG350M YE

- 3pc Wizard II Maple neck
- Basswood body
- Jumbo frets
- Edge III bridge
- INF3 (H) neck pu
- INF53 (S) mid pu
- INF4 (H) bridge pu
- Hardware color : Black
- Scale : 648mm/25.5"
- Color : YE (Yellow)



RG350EX BK

- 3pc Wizard II Maple neck
- Basswood body
- Jumbo frets
- Edge III bridge
- INF3 (H) neck pu
- INF53 (S) mid pu
- INF4 (H) bridge pu
- Hardware color : Cosmo Black
- Scale : 648mm/25.5"
- Color : BK (Black)

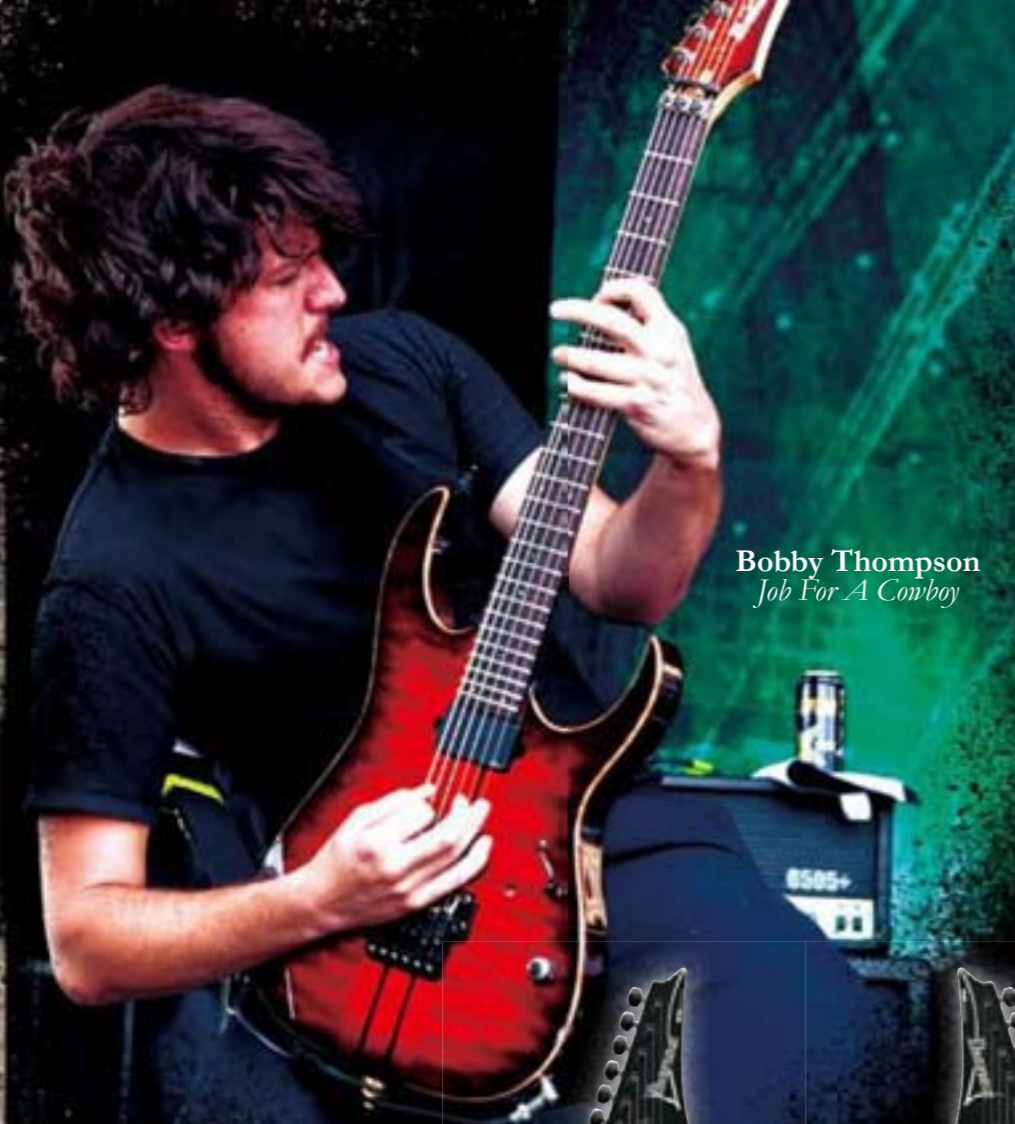

Bobby Thompson
Job For A Cowboy

RG TREMOLLO



EDGE III TREMOLO

The Edge III tremolo design provides even more stability and strength under the most demanding playing conditions. (model RG370DXBK)



RG370DX BK

- 3pc Wizard II Maple neck
- Basswood body
- Jumbo frets
- Edge III bridge
- INF3 (H) neck pu
- INF53 (S) mid pu
- INF4 (H) bridge pu
- Hardware color : Black
- Scale : 648mm/25.5"
- Colors : BK (Black)
WH (White)



RG370DX WH

- 3pc Wizard II Maple neck
- Basswood body
- Jumbo frets
- Edge III bridge
- INF3 (H) neck pu
- INF53 (S) mid pu
- INF4 (H) bridge pu
- Hardware color : Black
- Scale : 648mm/25.5"
- Colors : BK (Black)
WH (White)



RG370DX BKL

- 3pc Wizard II Maple neck
- Basswood body
- Jumbo frets
- Edge III bridge
- INF3 (H) neck pu
- INF53 (S) mid pu
- INF4 (H) bridge pu
- Hardware color : Black
- Scale : 648mm/25.5"
- Color : BK (Black)

Andy Timmons SIGNATURE MODEL

This multi-purpose axe has tone to spare, clean looks and a configuration of DiMarzio® pickups bound to make any guitarist's playing sparkle.



AT100CL CUSTOM DIMARZIO® PICKUP

The AT1 bridge pickup was specially designed and wound by DiMarzio® for Andy Timmons.

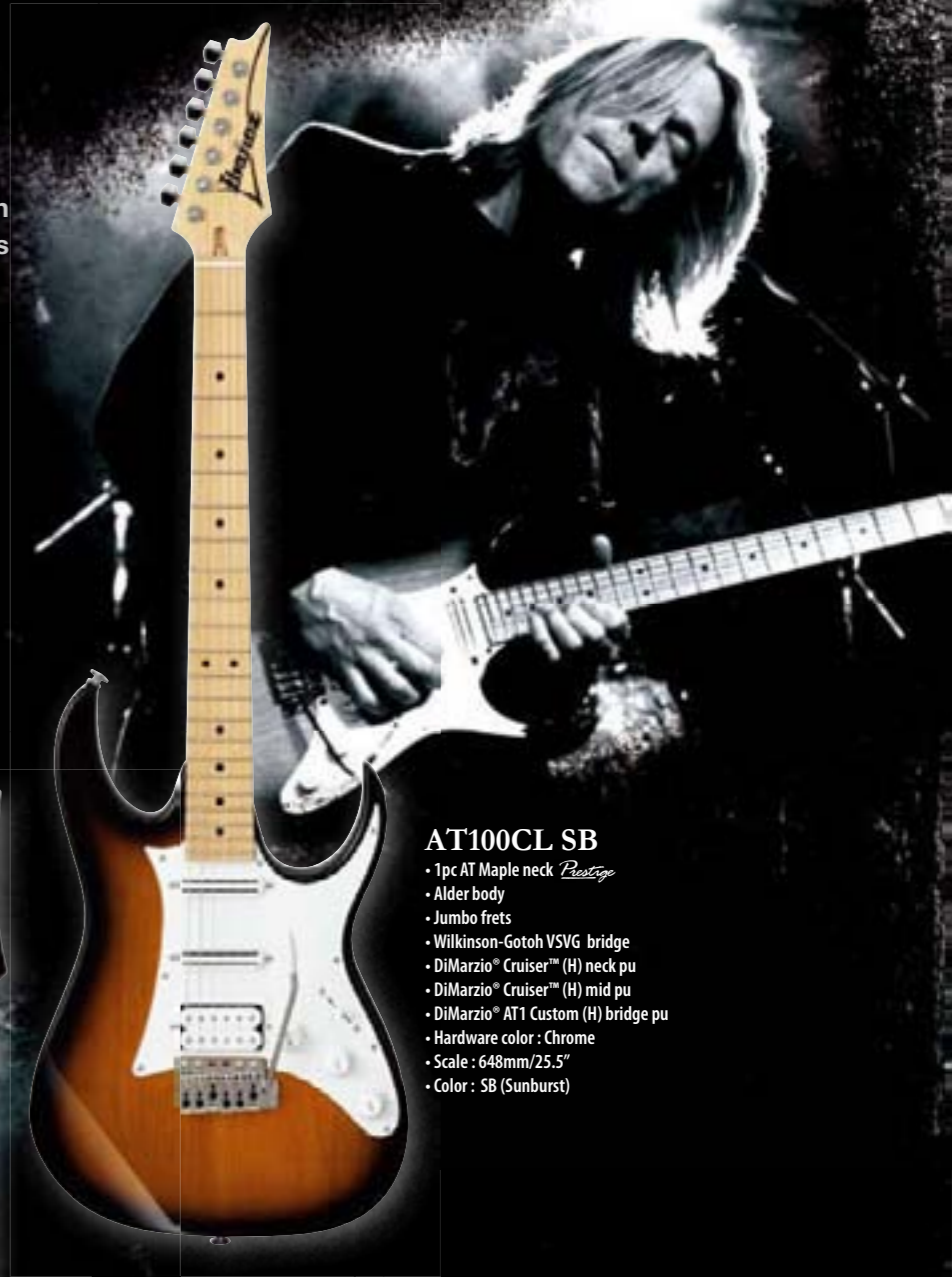
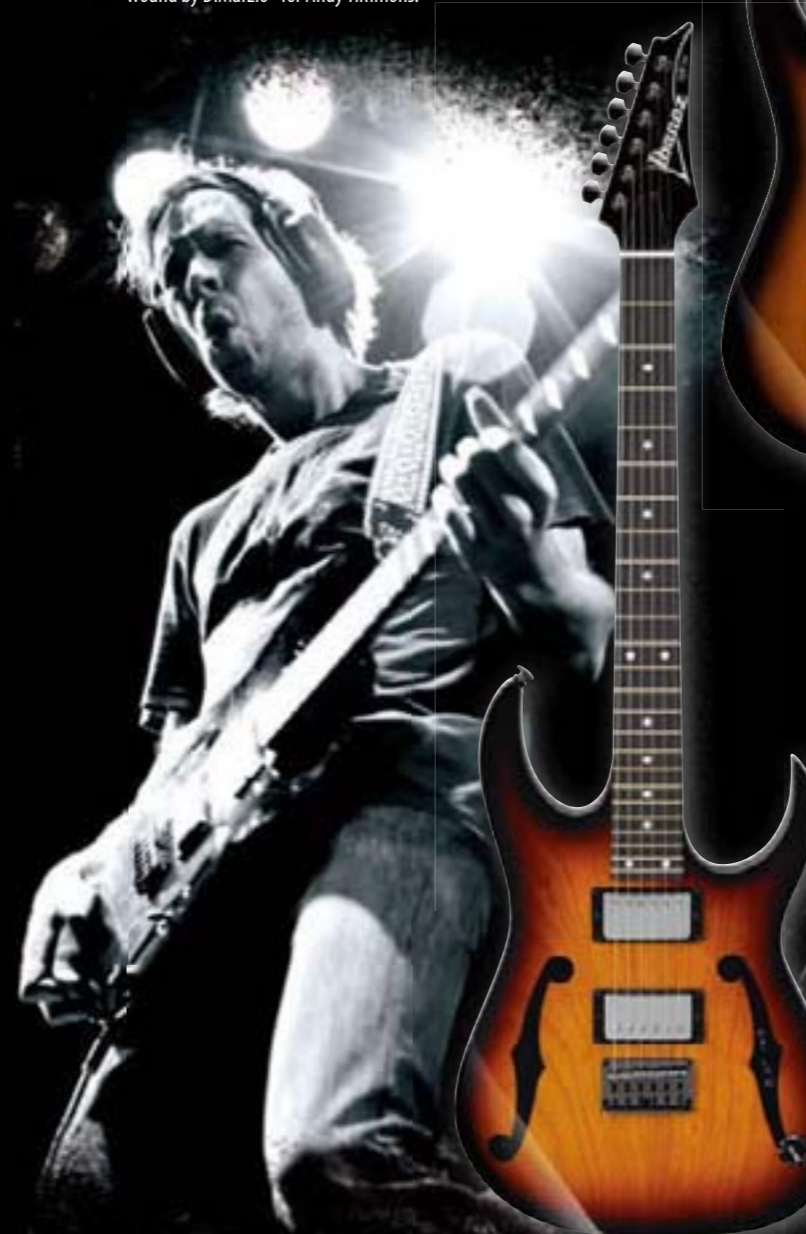

AT100CL SB

- 1pc AT Maple neck *Prestige*
- Alder body
- Jumbo frets
- Wilkinson-Gotoh VSVG bridge
- DiMarzio® Cruiser™ (H) neck pu
- DiMarzio® Cruiser™ (H) mid pu
- DiMarzio® AT1 Custom (H) bridge pu
- Hardware color : Chrome
- Scale : 648mm/25.5"
- Color : SB (Sunburst)

MR. BIG

Paul Gilbert SIGNATURE MODEL

Just offering a reissue of the original model wasn't enough for Paul. The 2009 PGM401 is a wholly different animal. With one exception: it still has Paul's famous painted f-holes.

PGM401 TFB

- 5pc PGM Maple /Walnut neck *Prestige*
- Ash body
- Medium frets
- Fixed bridge
- DiMarzio® Air Classic™ (H) neck pu
- DiMarzio® Air Classic™ (H) bridge pu
- Hardware color : Cosmo Black
- Scale : 648mm/25.5"
- Color : TFB (Tri Fade Burst)



TILT NECK JOINT

The traditional neck joint has a metal plate with 4 screws, yet the tilt joint still offers easy upper fret access. Paul likes this original neck joint for its tonal characteristics.

RG FIXED

Sometimes keeping things simple is the way to go. The RG Fixed series is for players who prefer a straightforward fixed bridge setup.



Terry Balsamo
Evanescence



Tony MacAlpine
Planet X



GIBRALTAR STANDARD BRIDGE

RG Fixed Series feature the Gibraltar Standard Bridge. Ready and able for wide intonation adjustment, but rock solid in standing up to the most aggressive playing. A bridge made for crossing the great divide over to heavier rock.



STRING THROUGH-THE-BODY

RG321MHMOL's through-body stringing increases sustain.

RG321MH MOL

- 3pc Wizard II Maple neck
- Mahogany body
- Jumbo frets
- Gibraltar Standard bridge
- INF3 (H) neck pu
- INF4 (H) bridge pu
- Hardware color: Cosmo Black
- Scale: 648mm/25.5"
- Colors: MOL (Mahogany Oil)
- BK (Black)
- CA (Candy Apple)

RG321MH BK

- 3pc Wizard II Maple neck
- Mahogany body
- Jumbo frets
- Gibraltar Standard bridge
- INF3 (H) neck pu
- INF4 (H) bridge pu
- Hardware color: Cosmo Black
- Scale: 648mm/25.5"
- Colors: MOL (Mahogany Oil)
- BK (Black)
- CA (Candy Apple)

RG321MH CA

- 3pc Wizard II Maple neck
- Mahogany body
- Jumbo frets
- Gibraltar Standard bridge
- INF3 (H) neck pu
- INF4 (H) bridge pu
- Hardware color: Cosmo Black
- Scale: 648mm/25.5"
- Colors: MOL (Mahogany Oil)
- BK (Black)
- CA (Candy Apple)



RG7321 BK

- 5pc Wizard II-7 Maple/Walnut neck
- Basswood body
- Jumbo frets
- Gibraltar Standard 7 bridge
- AH1-7 (H) neck pu
- AH2-7 (H) bridge pu
- Hardware color: Black
- Scale: 648mm/25.5"
- Color: BK (Black)



RG7321FM BBS

- 5pc Wizard II-7 Maple/Walnut neck
- Flamed Maple top/Basswood body
- Jumbo frets
- Gibraltar Standard 7 bridge
- AH1-7 (H) neck pu
- AH2-7 (H) bridge pu
- Hardware color: Cosmo Black
- Scale: 648mm/25.5"
- Color: BBS (Blackberry Sunburst)



Ihsahn
Ihsahn, Emperor

GIO

Whether you're a beginner looking for your first electric, or a working pro looking for a good backup for your main axe, the Ibanez GIO series delivers. GRG and GRX guitars feature the same playability, warranty and set-up as our most expensive instruments, but at rock bottom affordable prices.



GRG170DX CA

- GRG1 Maple neck
- Basswood body
- Medium frets
- Fat 10 bridge
- PSND1 (H) neck pu
- PSND5 (S) mid pu
- PSND2 (H) bridge pu
- Hardware color : Chrome
- Scale : 648mm/25.5"
- Colors : CA (Candy Apple)
BKN (Black Night)
JB (Jewel Blue)

GRG170DX BKN

- GRG1 Maple neck
- Basswood body
- Medium frets
- Fat 10 bridge
- PSND1 (H) neck pu
- PSND5 (S) mid pu
- PSND2 (H) bridge pu
- Hardware color : Chrome
- Scale : 648mm/25.5"
- Colors : CA (Candy Apple)
BKN (Black Night)
JB (Jewel Blue)



GRX20Z JB

- 1pc GRX Maple neck
- Basswood Body
- Medium frets
- FAT6 bridge
- PSND1(H) neck pu
- PSND2(H) bridge pu
- Hardware color : Chrome
- Scale : 648mm/25.5"
- Colors : BKN(Black Night)
JB (Jewel Blue)
RD (Red)
- Also Available
Left-handed in BKN finish

GRX20Z RD

- 1pc GRX Maple neck
- Basswood Body
- Medium frets
- FAT6 bridge
- PSND1(H) neck pu
- PSND2(H) bridge pu
- Hardware color : Chrome
- Scale : 648mm/25.5"
- Colors : BKN(Black Night)
JB (Jewel Blue)
RD (Red)
- Also Available
Left-handed in BKN finish

MIKRO

The little Mikro puts out sound way beyond its size – which is why, in just a few short years, it's become one of the most popular guitars in the history of Ibanez. Perfect for young rockers on the way up or seasoned road warriors on the tour bus. The mighty Mikro series includes left-handed models, vibrant colors and maple fretboards inspired by the classic 1987 "Ibanez Rebirth" RGs



MIKRO ROSEWOOD FRETBOARD W/SHARKTOOTH

GRGM21 guitars feature sharktooth inlays for big metal looks on a compact axe.



GRGM21 WH

- 1pc GRGM Maple neck
- Basswood body
- Medium frets
- Fixed bridge
- PSND1 (H) neck pu
- PSND2 (H) bridge pu
- Hardware color : Chrome
- Scale : 564mm/22.2"
- Colors : BKN (Black Night)
WH (White)

GRGM21 BKNL

- 1pc GRGM Maple neck
- Basswood body
- Medium frets
- Fixed bridge
- PSND1 (H) neck pu
- PSND2 (H) bridge pu
- Hardware color : Chrome
- Scale : 564mm/22.2"
- Color : BKN (Black Night)



GRGM21M YL

- 1pc GRGM Maple neck
- Basswood body
- Medium frets
- Fixed bridge
- PSND1 (H) neck pu
- PSND2 (H) bridge pu
- Hardware color : Chrome
- Scale : 564mm/22.2"
- Colors : JB (Jewel Blue)
RD (Red)
YL (Yellow)

GRGM21M JB

- 1pc GRGM Maple neck
- Basswood body
- Medium frets
- Fixed bridge
- PSND1 (H) neck pu
- PSND2 (H) bridge pu
- Hardware color : Chrome
- Scale : 564mm/22.2"
- Colors : JB (Jewel Blue)
RD (Red)
YL (Yellow)

GRGM21M RD

- 1pc GRGM Maple neck
- Basswood body
- Medium frets
- Fixed bridge
- PSND1 (H) neck pu
- PSND2 (H) bridge pu
- Hardware color : Chrome
- Scale : 564mm/22.2"
- Colors : JB (Jewel Blue)
RD (Red)
YL (Yellow)



MIKRO MAPLE FRETBOARD

GRGM21M's classic maple fretboard.

SHADOWS FALL
Matt Bachand
 SIGNATURE MODELS

Matt Bachand's heart-stopping signature guitars are offered in two different models. Yes, you ghouls, they both have Matt's evil skull graphic on their black-clad bodies.



MBM1 BK

- 5pc Wizard Maple/Walnut neck *Prestige*
- Mahogany body
- Jumbo frets
- Gibraltar Plus bridge
- EMG® 60 (H) neck pu
- EMG® 81 (H) bridge pu
- Hardware color : Cosmo Black
- Scale : 648mm/25.5"
- Factory tuning: 1D, 2A, 3F, 4C, 5G, 6D
- String gauge: .011/ .014/ .018/ .030/ .042/ .052
- Color : BK (Black)



MBM2 SV

- 3pc Wizard II Maple neck
- Mahogany body
- Jumbo frets
- Gibraltar Standard bridge
- EMG® 60 (H) neck pu
- EMG® 81 (H) bridge pu
- Hardware color : Black
- Scale : 648mm/25.5"
- Factory tuning: 1D, 2A, 3F, 4C, 5G, 6D
- String gauge: .011/ .014/ .018/ .030/ .042/ .052
- Color : SV (Silver)

RGA *Prestige*
 CRAFTED BY JAPAN'S FINEST LUTHIERS

The RGA archtop guitar not only has curves but playability. And for live performance, its lightweight body gives players more freedom to move on stage. The arched top also allows players to knock down heavy riffs and power chords without hitting the guitar body. Curved beauty and great performance combine gracefully in the RGA.



SPECIAL HORN CUT

The extra horn cut on the RGA Prestige allows even easier upper fret access than the deep cutaway on the classic RG.

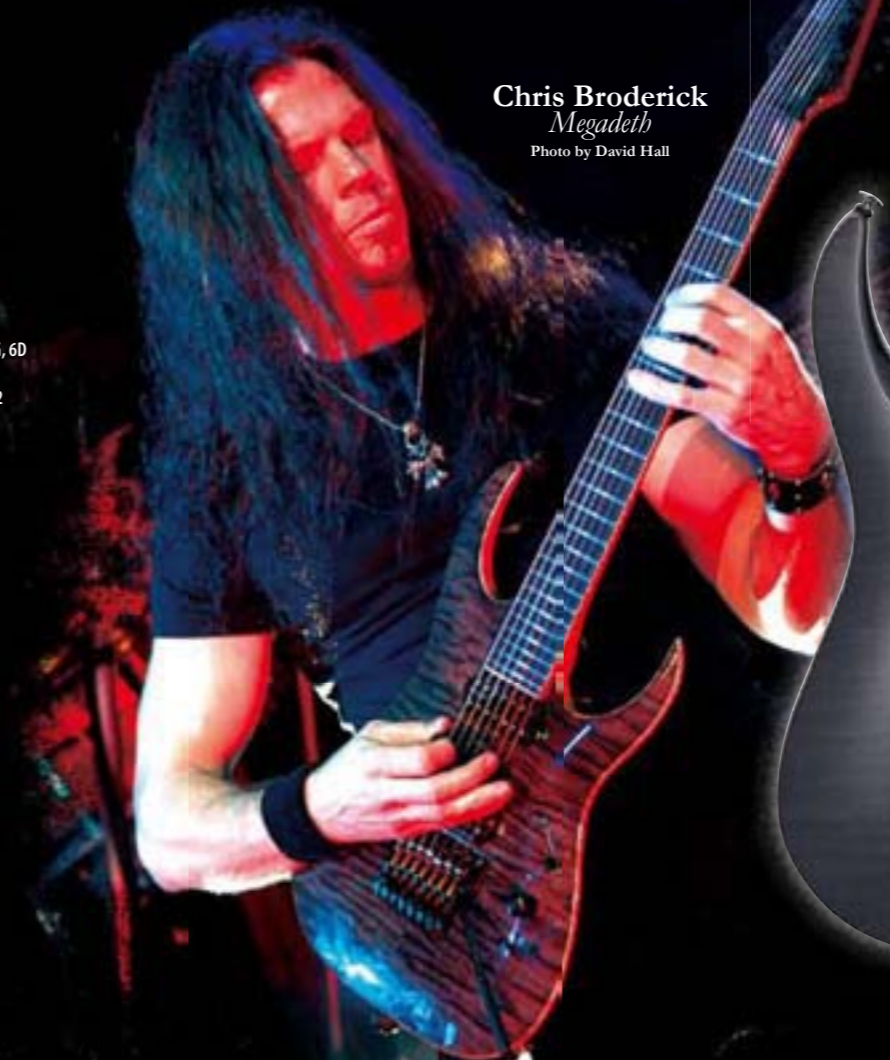

Chris Broderick

Megadeth
 Photo by David Hall

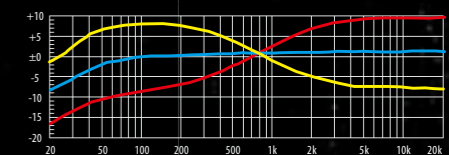
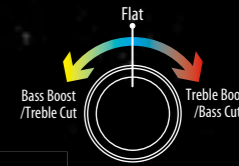

RGA420Z ACTIVE EQ

This EQ allows for everything from massive fat low tones to sharp treble tones through the turn of one knob with almost no change in output volume. The tone changes in a smooth and natural curve, so it's easy and quick to find the sound you're looking for.



LZ4 PICKUPS

Active pickup. Wide dynamic range from fat & heavy to bright & loud.



RGA420Z DSH

- 5pc Wizard HP Maple/Walnut neck *Prestige*
- Flamed Maple top/Mahogany body
- Jumbo frets
- Edge-Zero bridge w/ZPS3
- LZ4-N (H) neck pu
- LZ4-B (H) bridge pu
- Hardware color : Cosmo Black
- Scale : 648mm/25.5"
- Color : DSH (Devil's Shadow)



RGA72TQM BBS

- 3pc Wizard II Maple set-in neck w/KTS™ TITANIUM Reinforcement
- Quilted Maple top/ Mahogany body
- Jumbo frets
- Edge III bridge
- LZ3-N (H) neck pu
- LZ3-B (H) bridge pu
- Hardware color : Cosmo Black
- Scale : 648mm/25.5"
- Colors : TGB (Transparent Gray Burst) BBS (Blackberry Sunburst)



RGA72TQM TGB

- 3pc Wizard II Maple set-in neck w/KTS™ TITANIUM Reinforcement
- Quilted Maple top/ Mahogany body
- Jumbo frets
- Edge III bridge
- LZ3-N (H) neck pu
- LZ3-B (H) bridge pu
- Hardware color : Cosmo Black
- Scale : 648mm/25.5"
- Colors : TGB (Transparent Gray Burst) BBS (Blackberry Sunburst)



RGA72QM TGB

- 3pc Wizard II Maple set-in neck w/KTS™ TITANIUM Reinforcement
- Quilted Maple top/ Mahogany body
- Jumbo frets
- Gibraltar Standard bridge
- LZ3-N (H) neck pu
- LZ3-B (H) bridge pu
- Hardware color : Cosmo Black
- Scale : 648mm/25.5"
- Color : TGB (Transparent Gray Burst)

Brian Leppke
Bleeding Through



LZ3 PICKUPS

The LZ3 is also an original Ibanez active pickup, but with higher output than the LZ4. It produces a fat sound with good clarity perfect for distortion sounds.

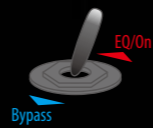

RGA ACTIVE EQ

Specially designed to function with the fat and strong LZ3 pickups, the output is controlled by an active circuit to provide pure tone free of noise.

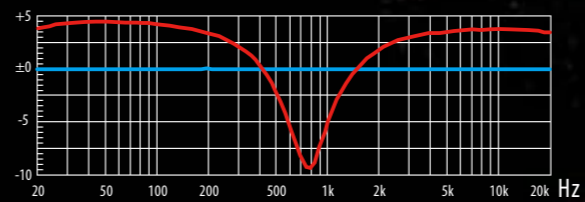

Mark Jansen
Epica



RGA42FM TRB

- 3pc Wizard II Maple neck
- Flamed Maple top/Mahogany body
- Jumbo frets
- Gibraltar Standard bridge
- LZ3-N (H) neck pu
- LZ3-B (H) bridge pu
- Hardware color : Cosmo Black
- Scale : 648mm/25.5"
- Colors : BBB(Bright Blue Burst) TGB(Transparent Gray Burst) TRB(Transparent Red Burst)



RGA42FM BBB

- 3pc Wizard II Maple neck
- Flamed Maple top/Mahogany body
- Jumbo frets
- Gibraltar Standard bridge
- LZ3-N (H) neck pu
- LZ3-B (H) bridge pu
- Hardware color : Cosmo Black
- Scale : 648mm/25.5"
- Colors : BBB(Bright Blue Burst) TGB(Transparent Gray Burst) TRB(Transparent Red Burst)



RGA42FM TGB

- 3pc Wizard II Maple neck
- Flamed Maple top/Mahogany body
- Jumbo frets
- Gibraltar Standard bridge
- LZ3-N (H) neck pu
- LZ3-B (H) bridge pu
- Hardware color : Cosmo Black
- Scale : 648mm/25.5"
- Colors : BBB(Bright Blue Burst) TGB(Transparent Gray Burst) TRB(Transparent Red Burst)



RGA32 BKF

- 3pc Wizard II Maple neck
- Mahogany body
- Jumbo frets
- Gibraltar Standard bridge
- LZ3-N (H) neck pu
- LZ3-B (H) bridge pu
- Hardware color : Cosmo Black
- Scale : 648mm/25.5"
- Colors : BKF (Black Flat) TYF (Titanium Gray Flat)



RGA32 TYF

- 3pc Wizard II Maple neck
- Mahogany body
- Jumbo frets
- Gibraltar Standard bridge
- LZ3-N (H) neck pu
- LZ3-B (H) bridge pu
- Hardware color : Cosmo Black
- Scale : 648mm/25.5"
- Colors : BKF (Black Flat) TYF (Titanium Gray Flat)

RGA



JB Brubaker
August Burns Red
Photo by Cory Morton



FX EDGE III-8 BRIDGE

Combines fixed bridge sustain and double-locking stability.



RGA8 BK

- 5pc Wizard II-8 Maple/Walnut neck w/KTS™ TITANIUM Reinforcement
- Mahogany body
- Jumbo frets
- FX Edge III-8 bridge
- LZ8-N (H) neck pu
- LZ8-B (H) bridge pu
- Hardware color : Black
- Scale : 685.8mm/27"
- Color : BK (Black)



RGA7 BK

- 5pc Wizard II-7 Maple/Walnut neck
- Mahogany body
- Jumbo frets
- Gibraltar Standard-7 bridge
- LZ7-N (H) neck pu
- LZ7-B (H) bridge pu
- Hardware color : Cosmo Black
- Scale : 648mm/25.5"
- Color : BK (Black)



GRGA32 BKN

- 1pc GRGA1 Maple neck
- Mahogany body
- Medium frets
- Fixed bridge
- PSND1 (H) neck pu
- PSND2 (H) bridge pu
- Hardware color : Black
- Scale : 648mm/25.5"
- Color : BKN (Black Night)



GRGA32T WH

- 1pc GRGA1 Maple neck
- Mahogany body
- Medium frets
- Edge III bridge
- PSND1 (H) neck pu
- PSND2 (H) bridge pu
- Hardware color : Black
- Scale : 648mm/25.5"
- Colors : BKN (Black Night) WH (White)



GRGA32T BKN

- 1pc GRGA1 Maple neck
- Mahogany body
- Medium frets
- Edge III bridge
- PSND1 (H) neck pu
- PSND2 (H) bridge pu
- Hardware color : Black
- Scale : 648mm/25.5"
- Colors : BKN (Black Night) WH (White)



EDGE III BRIDGE

The Edge III tremolo design provides even more stability and strength under the most demanding playing conditions.

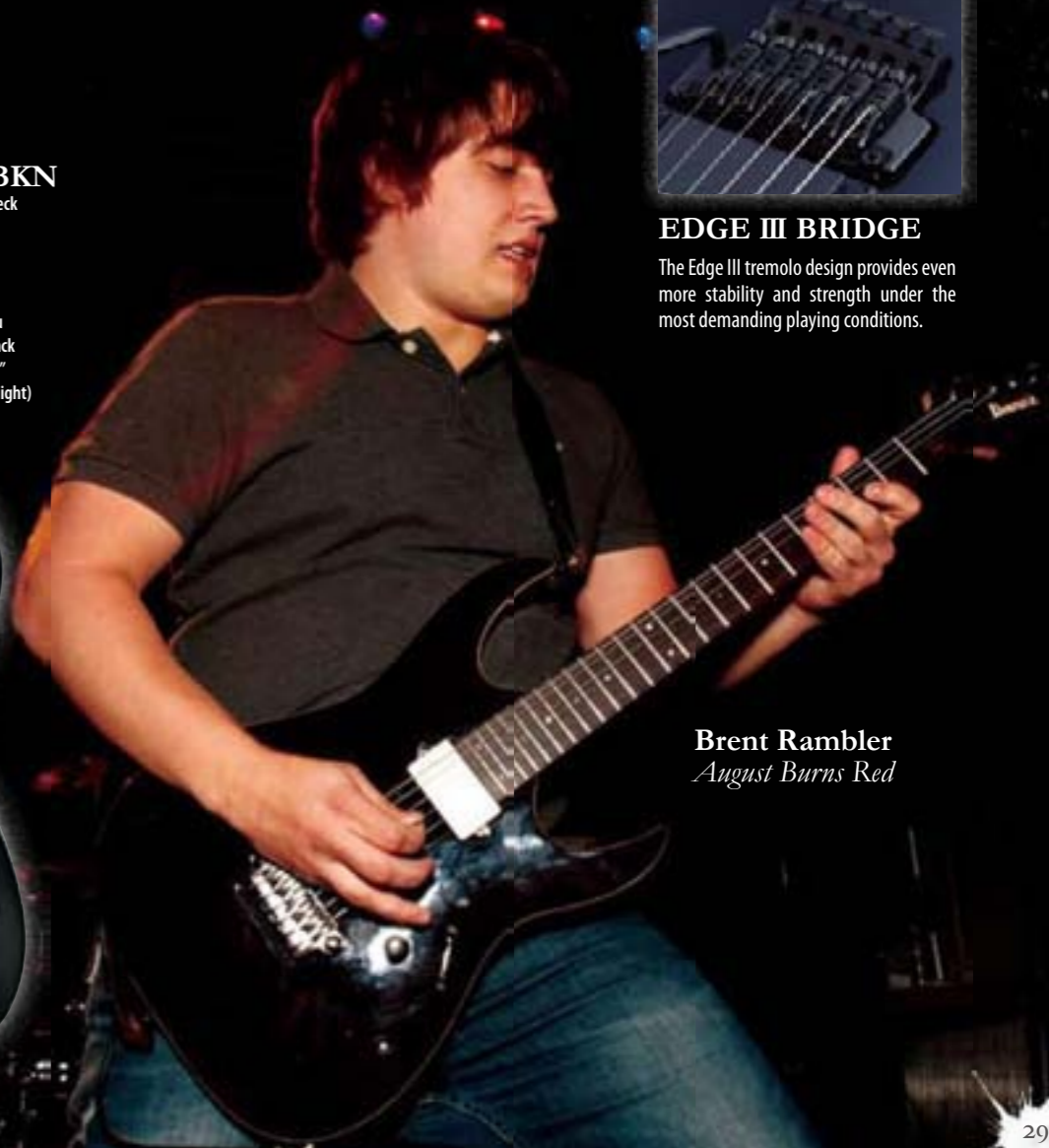

Brent Rambler
August Burns Red

RGD *Prestige*

CRAFTED BY JAPAN'S FINEST LUTHIERS

As a pioneer of heavy rock guitars, Ibanez has released 7- and 8-string models in the past. This year we release the RGD, Ibanez's new heavy metal machine. Down tuned metal guitars are required to output clear sound down to the lowest note without losing playability. So we kept the extension of the

neck scale to the minimum (1 inch), and original tuned pickups are mounted and ready to ride. Hottest metal player? I wanna say latest guitar player usually hold their guitars low, and the sharp-shaped RGD body achieves good balance and easier access to high frets for low-slingers.



RGD2120Z CSM

- 5pc Wizard HP Maple/Walnut neck *Prestige* w/KTS™ TITANIUM Reinforcement
- Basswood body
- Jumbo frets
- Edge-Zero bridge w/ZPS3
- V7 Custom (H) neck pu
- V8 Custom (H) bridge pu
- Hardware color : Cosmo Black
- Scale : 672mm/26.5"
- Factory tuning : 1D, 2A, 3F, 4C, 5G, 6D
- String gauge : .010/ .013/ .017/ .026/ .036/ .046
- Color : CSM (Cobweb Silver Metallic)



RGD2127Z ISH

- 5pc Wizard-7 Maple/Walnut neck *Prestige* w/KTS™ TITANIUM Reinforcement
- Basswood body
- Jumbo frets
- Edge-Zero 7 bridge w/ZPS3
- V77 Custom (H) neck pu
- V87 Custom (H) bridge pu
- Hardware color : Cosmo Black
- Scale : 672mm/26.5"
- Factory tuning : 1D, 2A, 3F, 4C, 5G, 6D, 7A
- String gauge : .010/ .013/ .017/ .026/ .036/ .046/ .054
- Color : ISH (Invisible Shadow)



RGD320 MGS

- 3pc Wizard II Maple neck
- Basswood body
- Jumbo frets
- Edge III bridge
- VK1-DT (H) neck pu
- VK2-DT (H) bridge pu
- Hardware color : Black
- Scale : 672mm/26.5"
- Factory tuning : 1D, 2A, 3F, 4C, 5G, 6D
- String gauge : .010/ .013/ .017/ .026/ .036/ .046
- Colors : MGS (Metallic Gray Sunburst) WH (White)



RGD320 WH

- 3pc Wizard II Maple neck
- Basswood body
- Jumbo frets
- Edge III bridge
- VK1-DT (H) neck pu
- VK2-DT (H) bridge pu
- Hardware color : Black
- Scale : 672mm/26.5"
- Factory tuning : 1D, 2A, 3F, 4C, 5G, 6D
- String gauge : .010/ .013/ .017/ .026/ .036/ .046
- Colors : MGS (Metallic Gray Sunburst) WH (White)

VK-DT (DOWN TUNZ) PICKUPS

Model RGD320 MGS features VK Down Tunz pickups for faster, easier and truer down tuning. VK1 Down Tunz (at neck position), and VK2 Down Tunz (at bridge position).



SCOOP CUTS FOR EXCELLENT PLAYABILITY (RGD2120ZCSM)

A 26.5" extra long scale neck with whole step down tuning at factory. Specially designed to bring out more low-end by capturing a wider sound range, enabling rich, harmonic tone.



VINTAGE 7 CUSTOM NECK PICKUPS

Tight, but bright. Very dynamic for chording and rhythm.

VINTAGE 8 CUSTOM BRIDGE PICKUPS

Warm yet articulate lead pickup with enhanced overtones. Good harmonics without excessive brightness.



TOOL

The all-purpose maintenance tool is included with all Prestige models.

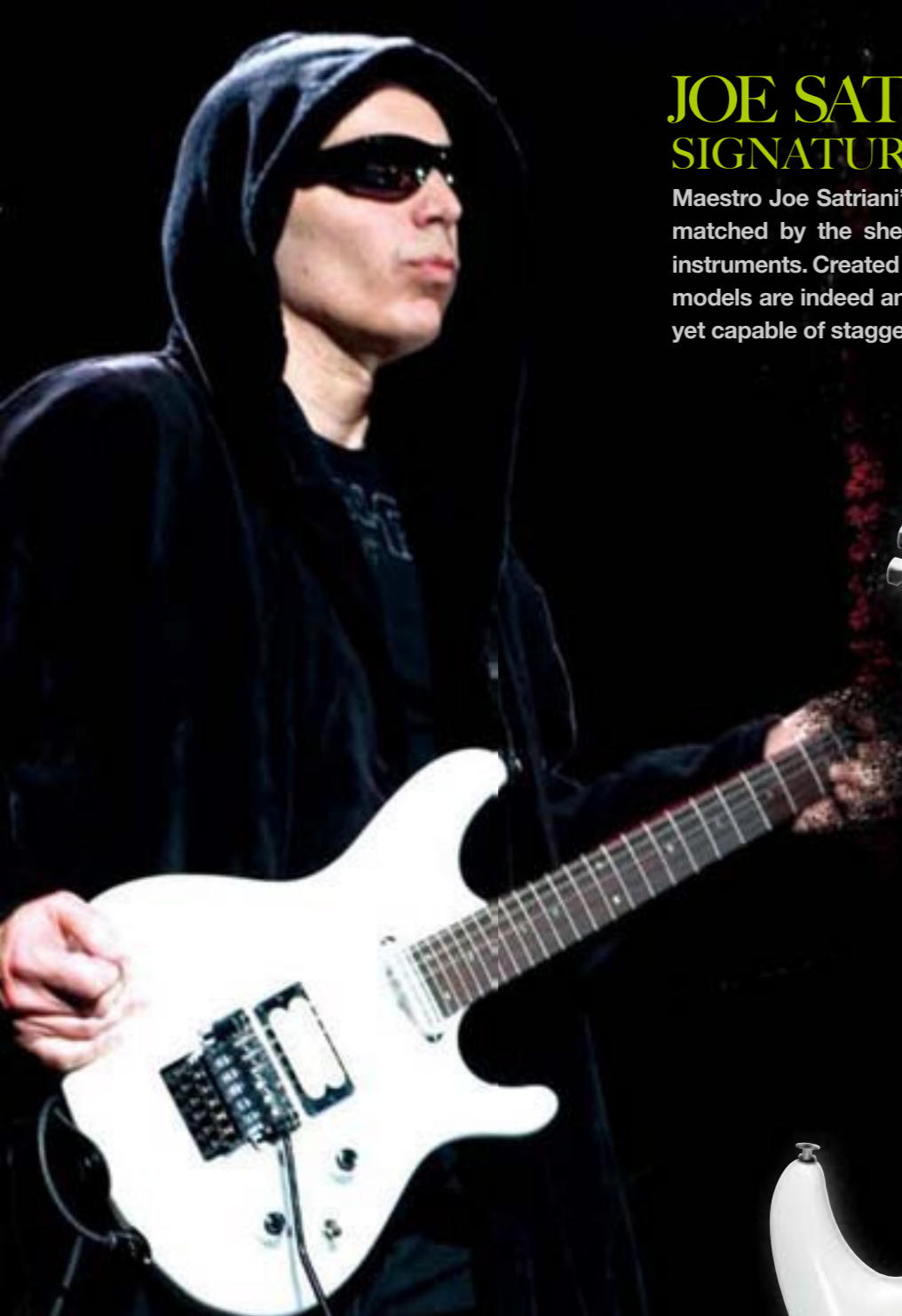

JOE SATRIANI SIGNATURE MODELS

Maestro Joe Satriani's jaw-dropping skill on the guitar is only matched by the sheer beauty and artistry of his Signature instruments. Created in collaboration with Satch himself, these models are indeed an extension of his playing: finely nuanced yet capable of staggering heights of musicality.

DIMARZIO® PRO-TRACK™ & MO' JOE™ PICKUPS (JS2400WH)



JS2400WH 24-FRET BOARD

The first 24-fret fingerboard JS model is Joe Satriani's newest adventure in guitars and includes his favorite DiMarzio® pickups.



JS2400 WH

- 1pc JS Maple neck *Prestige*
- Basswood body
- W/6105 frets
- Edge bridge
- DiMarzio® Pro Track™ (H) neck pu
- DiMarzio® Mo' Joe™ (H) bridge pu
- Hardware color : Chrome
- Scale : 648mm/25.5"
- Color : WH (White)



JS1200 CA

- 1pc JS Maple neck *Prestige*
- Basswood body
- W/6105 frets
- Edge bridge
- DiMarzio® Paf Joe™ (H) neck pu
- DiMarzio® Fred® (H) bridge pu
- Hardware color : Chrome
- Scale : 648mm/25.5"
- Color : CA (Candy Apple)



JS1600 PSV

- 1pc JS Maple neck *Prestige*
- Mahogany body
- W/6105 frets
- Fixed bridge
- DiMarzio® Paf Pro® (H) neck pu
- DiMarzio® Fred® (H) bridge pu
- Hardware color : Chrome
- Scale : 648mm/25.5"
- Color : PSV (Premium Silver)

JS COIL TAP SWITCHING SYSTEM H-H (JS2400)

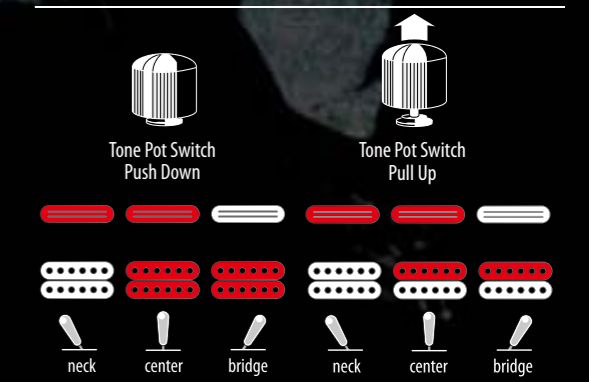

H-H (JS1600/JS1200/JS1000/JS100)

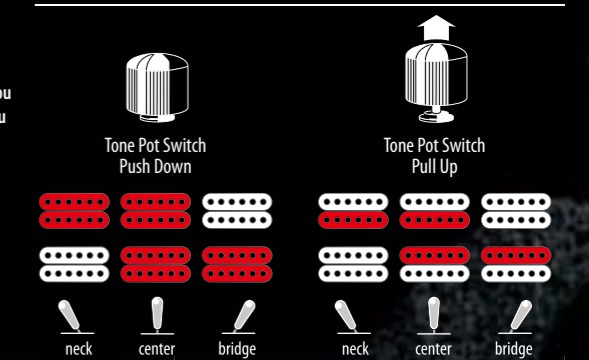

JS1000 BK

- 1pc JS Maple neck *Prestige*
- Basswood body
- W/6105 frets
- Edge bridge
- DiMarzio® Paf Pro® (H) neck pu
- DiMarzio® Fred® (H) bridge pu
- Hardware color : Cosmo Black
- Scale : 648mm/25.5"
- Color : BP (Black Pearl)



JS100 TR

- 1pc JS Maple neck
- Basswood body
- Large frets
- Edge III bridge
- AH1 (H) neck pu
- AH2 (H) bridge pu
- Hardware color : Chrome
- Scale : 648mm/25.5"
- Colors : BK (Black)
- TR (Transparent Red)



EGEN18 TVF

- 5pc EGEN Maple/Walnut neck *Prestige*
- Flamed Maple top/Mahogany body
- Jumbo frets
- Edge-Zero bridge w/ZPS3
- DiMarzio® HLM (H) neck pu
- DiMarzio® HLM (S) mid pu
- DiMarzio® HLM (H) bridge pu
- Hardware color : Gold
- Scale : 648mm/25.5"
- Color : TVF (Transparent Violet Flat)

EGEN8 PLB

- 3pc Wizard II Maple neck
- Flamed Maple top /Mahogany body
- Jumbo frets
- Edge III bridge (Herman Li special)
- V7 (H) neck pu
- S1 (S) mid pu
- V8 (H) bridge pu
- Hardware color : Gold
- Scale : 648mm/25.5"
- Color : PLB (Platinum Blonde)



DRAGONFORCE Herman Li SIGNATURE MODELS

When DragonForce guitarist Herman Li wanted a guitar that could handle his otherworldly technique and musicality, both he and Ibanez knew it would take time to get everything just right. It took three years. But they did get it right. The Ibanez E-Gen is played by Li exactly as it is, live on stage, in the studio, right off the shelf without any modifications.



EGEN18TVF'S SCALLOPED FRETBOARD (FRETS 21-24)

The scalloped fingerboard on the uppermost frets (21-24) is Herman Li's own touch, for easier high note bending and tapping.

EGEN8 PLB'S KUNG-FU GRIP AT HORN

Special scalloped hand grip on the top horn of the EGEN8, modeled from Herman's actual right hand.



EGEN PICKUP SWITCHING SYSTEM H-S-H (5WAY) EGEN

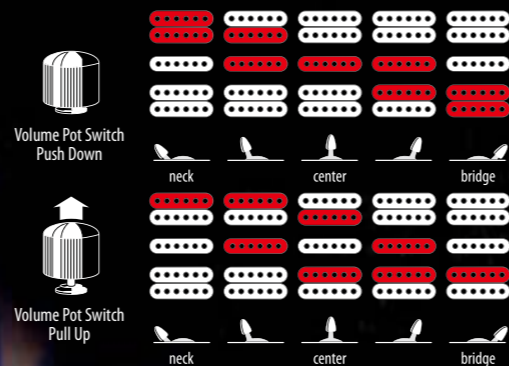

STM1 WH

- 5pc Wizard II Maple/Walnut neck-thru w/KTS™ TITANIUM Reinforcement
- Mahogany wing body
- Jumbo frets
- Edge III bridge
- DiMarzio® Evolution® (H) neck pu
- DiMarzio® Evolution® (H) bridge pu
- Hardware color : Chrome
- Scale : 648mm/25.5"
- Color : WH (White)



DRAGONFORCE Sam Totman SIGNATURE MODEL

Few guitarists have the shred skills and unshakable nerve like DragonForce's Sam Totman. Sam's Signature Iceman-shaped STM1WH is a 24-fret mahogany monster made for only the strongest of metal warriors.

S Serious Versatility *Prestige*

CRAFTED BY JAPAN'S FINEST LUTHIERS

The S Prestige series is "Made in Japan" by the finest Ibanez craftsmen and from top-of-the-line components. This beautifully contoured shape, combined with the ZR-2 tremolo system, produces warm resonant tones from a super thin mahogany body.



Buz McGrath
Unearth



S5470F SPB

- 5pc Super Wizard HP Maple/Walnut neck *Prestige*
- w/KTS™ TITANIUM Reinforcement
- Flamed Maple top/ Mahogany body
- Jumbo frets
- ZR-2 bridge w/ZPS3
- HGD1 (H) neck pu
- ST2 (S) middle pu
- HGD2 (H) bridge pu
- Hardware color : Cosmo Black
- Scale : 648mm/25.5"
- Colors : RVK (Red Viking) SPB (Sapphire Blue)



S5470F RVK

- 5pc Super Wizard HP Maple/Walnut neck *Prestige*
- w/KTS™ TITANIUM Reinforcement
- Flamed Maple top/ Mahogany body
- Jumbo frets
- ZR-2 bridge w/ZPS3
- HGD1 (H) neck pu
- ST2 (S) middle pu
- HGD2 (H) bridge pu
- Hardware color : Cosmo Black
- Scale : 648mm/25.5"
- Colors : RVK (Red Viking) SPB (Sapphire Blue)



S5470 TKS

- 5pc Super Wizard HP Maple/Walnut neck *Prestige*
- w/KTS™ TITANIUM Reinforcement
- Mahogany body
- Jumbo frets
- ZR-2 bridge w/ZPS3
- HGD1 (H) neck pu
- ST2 (S) middle pu
- HGD2 (H) bridge pu
- Hardware color : Cosmo Black
- Scale : 648mm/25.5"
- Color : TKS (Transparent Black Sunburst)

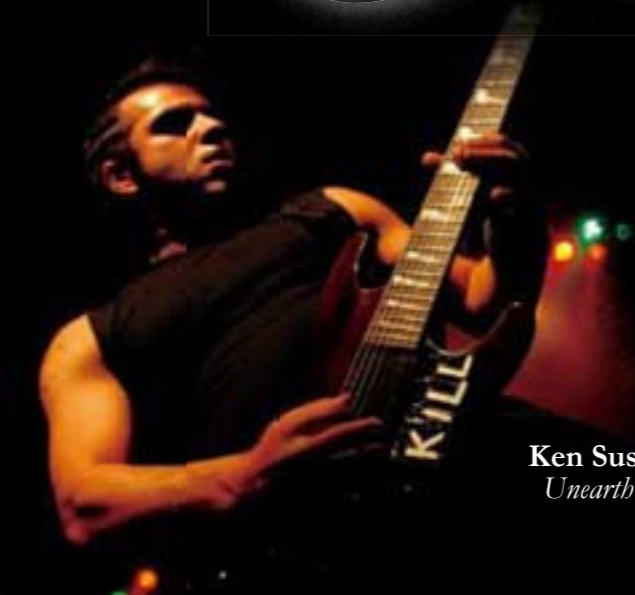

Ken Susi
Unearth



ZR-2 TREMOLO

The ZR-2 is a revolutionary tremolo system. It plays incredibly smooth through the use of its ball bearing mechanism. This also keeps the string action constant, even during the most rigorous tremolo use. The top side features a smooth finish for total hand comfort, and the tremolo arm snaps in for quick setup.

ZPS3 ZERO POINT SYSTEM

The ZPS3 is the next stage of zero point systems. Made of lightweight Duralumin, the addition of two outer springs makes the guitar easier to tune and provides much greater tuning stability. If you prefer a full floating tremolo setup, simply remove the stop bar.





Luke Hoskin
Protest the Hero

S The Ibanez S series first appeared in 1987. Ever since, it has changed in appearance and function to represent the cutting edge of Ibanez design. Famous for its lightweight carved mahogany body, the S can take a beating while still providing the resonance of guitars twice its size. The S series also comes equipped with the ZR tremolo system, a smooth ball bearing tremolo that makes every subtle nuance of whammy bar use come alive.



24-FRET S

With a two-octave fretboard, the new S models allow players even more creative freedom.



S770PB NTF

- 3pc Wizard II Maple neck
- Poplar Burl top/Mahogany body
- Jumbo frets
- ZR bridge w/ZPS2
- INF1 (H) neck pu
- INF51 (S) mid pu
- INF2 (H) bridge pu
- Hardware color : Cosmo Black
- Scale : 648mm/25.5"
- Color : NTF (Natural Flat)

S570DXQM TGB

- 3pc Wizard II Maple neck
- Quilted Maple top/Mahogany body
- Jumbo frets
- ZR bridge w/ZPS2
- INF1 (H) neck pu
- INF51 (S) mid pu
- INF2 (H) bridge pu
- Hardware color : Cosmo Black
- Scale : 648mm/25.5"
- Colors : TGB (Transparent Gray Burst)
- BBB (Bright Blue Burst)

S570DXQM BBB

- 3pc Wizard II Maple neck
- Quilted Maple top/Mahogany body
- Jumbo frets
- ZR bridge w/ZPS2
- INF1 (H) neck pu
- INF51 (S) mid pu
- INF2 (H) bridge pu
- Hardware color : Cosmo Black
- Scale : 648mm/25.5"
- Colors : TGB (Transparent Gray Burst)
- BBB (Bright Blue Burst)



S420 WK

- 3pc Wizard II Maple neck
- Mahogany body
- Jumbo frets
- ZR bridge w/ZPS2
- INF1 (H) neck pu
- INF2 (H) bridge pu
- Hardware color : Cosmo Black
- Scale : 648mm/25.5"
- Color : WK (Weathered Black)

S570B RD

- 3pc Wizard II Maple neck
- Mahogany body
- Jumbo frets
- ZR bridge w/ZPS2
- INF1 (H) neck pu
- INF51 (S) mid pu
- INF2 (H) bridge pu
- Hardware color : Black
- Scale : 648mm/25.5"
- Colors : RD (Red)
- WH (White)

S570B WH

- 3pc Wizard II Maple neck
- Mahogany body
- Jumbo frets
- ZR bridge w/ZPS2
- INF1 (H) neck pu
- INF51 (S) mid pu
- INF2 (H) bridge pu
- Hardware color : Black
- Scale : 648mm/25.5"
- Colors : RD (Red)
- WH (White)

S7420 BK

- 3pc Wizard II-7 Maple neck
- Mahogany body
- Jumbo frets
- ZR-7 bridge w/ZPS2
- AH1-7 (H) neck pu
- AH2-7 (H) bridge pu
- Hardware color : Cosmo Black
- Scale : 648mm/25.5"
- Color : BK (Black)

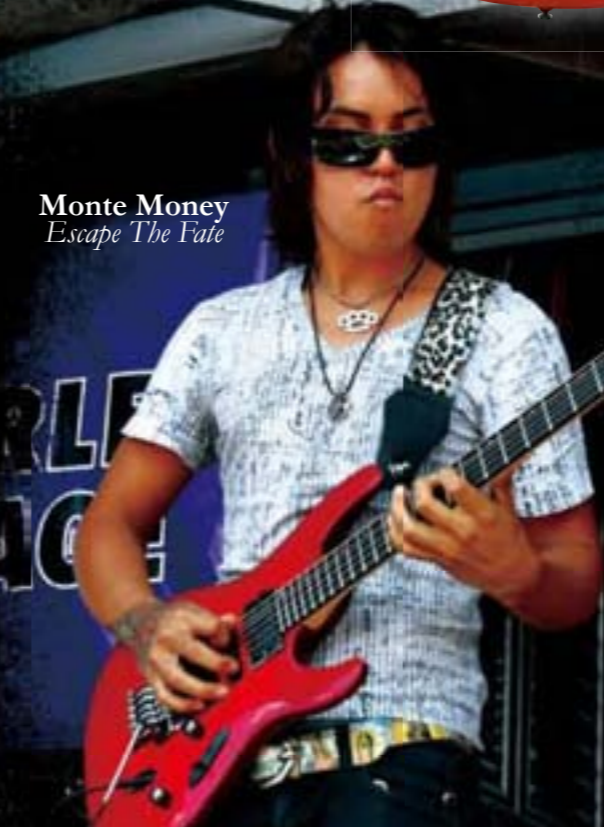

Monte Money
Escape The Fate

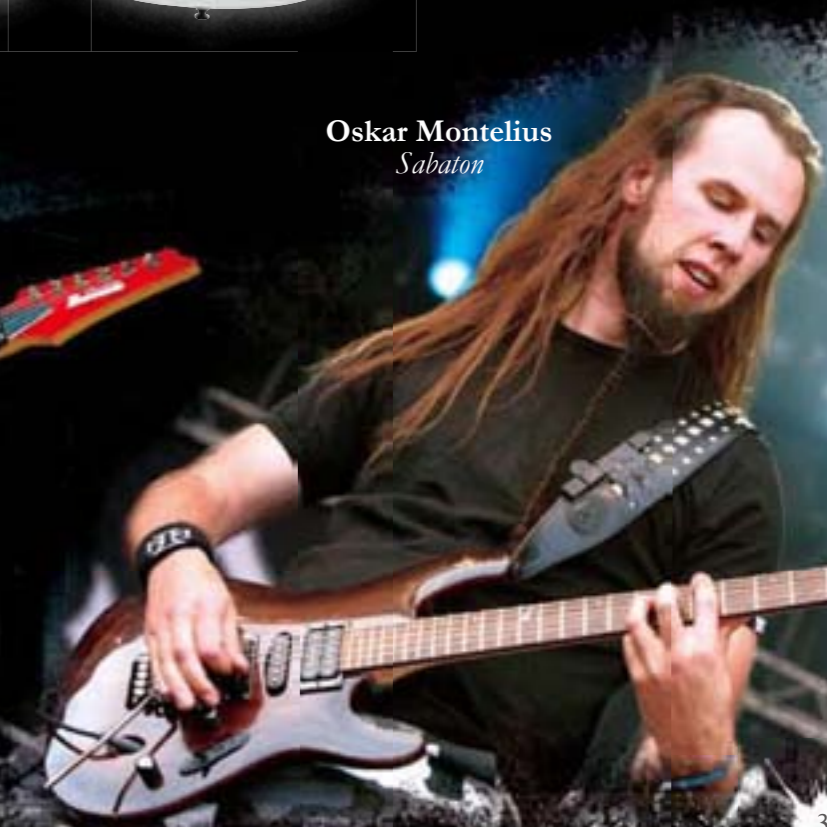

Oskar Montelius
Sabaton

ICEMAN

Ibanez smashed through conventional guitar looks with the Iceman guitar, in one of rock's most unforgettable shapes. 24-fret mahogany monsters for those who want to let loose an avalanche of rock.



ICT700 WH

- 5pc Wizard II Maple/Walnut neck-thru w/KTS™ TITANIUM Reinforcement
- Mahogany wing body
- Jumbo frets
- Gibraltar Custom bridge
- DiMarzio® D Activator™ (H) neck pu
- DiMarzio® D Activator™ (H) bridge pu
- Hardware color: Black
- Scale: 648mm/25.5"
- Colors: BK (Black) WH (White)

ICT700 BK

- 5pc Wizard II Maple/Walnut neck-thru w/KTS™ TITANIUM Reinforcement
- Mahogany wing body
- Jumbo frets
- Gibraltar Custom bridge
- DiMarzio® D Activator™ (H) neck pu
- DiMarzio® D Activator™ (H) bridge pu
- Hardware color: Black
- Scale: 648mm/25.5"
- Colors: BK (Black) WH (White)



THRU-NECK CONSTRUCTION

Back view of the DTT700MGS's 5pc Maple/Walnut Wizard II thru-neck, which increases playability, tone and sustain.



DIMARZIO® D ACTIVATOR-X™ PICKUPS

The DTT700MGS features the snarling DiMarzio® D Activator X™ pickups in both neck and bridge position.

Eyal Levi
Dåath

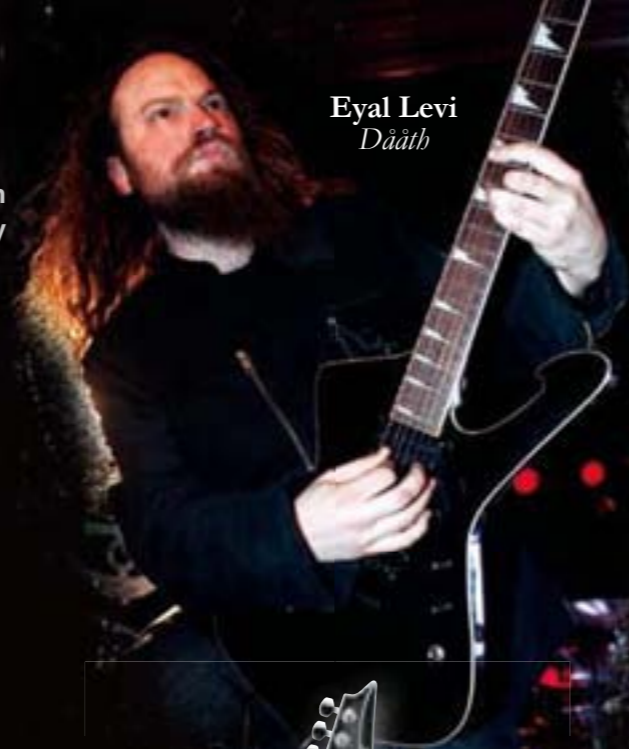

DTT700 MGS

- 5pc Wizard II Maple/Walnut neck-thru w/KTS™ TITANIUM Reinforcement
- Mahogany wing body
- Jumbo frets
- Gibraltar Custom bridge
- DiMarzio® D Activator-X™ (H) neck pu
- DiMarzio® D Activator-X™ (H) bridge pu
- Hardware color: Chrome
- Scale: 648mm/25.5"
- Color: MGS (Metallic Gray Sunburst)



Nightmare Industries
Deathstars



DN DARKSTONE

The DN is the new standard in heavy metal rock guitar. As its "Darkstone" series name suggests, strong construction and smart body style combine for a powerful, clean sound.



DN500K BK

- 1pc DN Sapele set-in neck
- Sapele body
- Medium frets
- Tight-Tune bridge
- Tight-Tune tailpiece
- PP1-N (H) neck pu
- PP1-B (H) bridge pu
- Hardware color: Cosmo Black
- Scale: 628mm/24.75"
- Colors: BK (Black) WH (White)

DN500K WH

- 1pc DN Sapele set-in neck
- Sapele body
- Medium frets
- Tight-Tune bridge
- Tight-Tune tailpiece
- PP1-N (H) neck pu
- PP1-B (H) bridge pu
- Hardware color: Cosmo Black
- Scale: 628mm/24.75"
- Colors: BK (Black) WH (White)



PP1 PICKUPS

Tube pole-piece construction offers quick response, sparkling clarity and added harmonics for a humbucker sound.



TIGHT-TUNE BRIDGE AND TAILPIECE

Solid as a rock, the Tight-Tune bridge and tailpiece were designed to lock down securely and prevent any kind of wobble or movement. Each saddle is locked into the base plate, and the bridge is anchored by stud bolts into the guitar body. Studs are also locked onto the base plate for maximum transfer of string vibration to the body.

Marcus Sunesson
Engel

Niclas Engelin
Engel



DESTROYER

The Destroyer, a dark spectre from Ibanez's past – updated neck-thru construction and DiMarzio® D Activator-X™ pickups. You wanna rock hard?

Rikard Sundén
Sabatón

Christoph Siemons
Krypteria

Photo by Tim Tronekoc

Logan
Deadly Motor Vehicles



XIPHOS

With the advent of the X series, Ibanez reintroduced non-traditional guitar shapes back into the mix. These off-the-wall shapes stand out in a crowd, but they are also excellent examples of form meeting function. The XPT was developed for the extreme shred player with its fast neck and tremolo system.

Dino Cazares
Fear Factory, Divine Heresy



27 FRET NECK

The wicked XPT700XHGSF features a 27-fret 5-piece maple/walnut Wizard II thru-neck.

XPT700 WH

- 5pc Wizard II Maple/Walnut neck-thru w/KTS™ TITANIUM Reinforcement
- Mahogany wing body
- Jumbo frets
- Edge III bridge
- DiMarzio® D Activator™ (H) neck pu
- DiMarzio® D Activator™ (H) bridge pu
- Hardware color: Cosmo Black
- Scale: 648mm/25.5"
- Colors: RCM (Red Chameleon) WH (White)

XPT700 RCM

- 5pc Wizard II Maple/Walnut neck-thru w/KTS™ TITANIUM Reinforcement
- Mahogany wing body
- Jumbo frets
- Edge III bridge
- DiMarzio® D Activator™ (H) neck pu
- DiMarzio® D Activator™ (H) bridge pu
- Hardware color: Cosmo Black
- Scale: 648mm/25.5"
- Colors: RCM (Red Chameleon) WH (White)

XPT700XH GSF

- 5pc Wizard II Maple/Walnut neck-thru w/KTS™ TITANIUM Reinforcement
- Mahogany wing body
- Jumbo frets
- Edge III bridge
- DiMarzio® Air Norton 5™ (H) neck pu
- DiMarzio® D Activator™ (H) bridge pu
- Hardware color: Black
- Scale: 648mm/25.5"
- Color: GSF (Green Shadow Flat)



THRU-NECK CONSTRUCTION

XPT700's neck-thru construction and mahogany body.



XP300FX BK

- 3pc Wizard II Maple neck
- Mahogany body
- Jumbo frets
- Fixed bridge
- INF3 (H) neck pu
- INF4 (H) bridge pu
- Hardware color: Cosmo Black
- Scale: 648mm/25.5"
- Color: BK (Black)

XP300 IPT

- 3pc Wizard II Maple neck
- Mahogany body
- Jumbo frets
- Edge III bridge
- INF3 (H) neck pu
- INF4 (H) bridge pu
- Hardware color: Cosmo Black
- Scale: 648mm/25.5"
- Color: IPT (Iron Pewter)



Oli Herbert
All That Remains



XPT707FX GCM

- 5pc Wizard II-7 Maple/Walnut neck-thru w/KTS™ TITANIUM Reinforcement
- Mahogany wing body
- Jumbo frets
- Gibraltar Custom-7 bridge
- DiMarzio® D Activator 7™ (H) neck pu
- DiMarzio® D Activator 7™ (H) bridge pu
- Hardware color: Cosmo Black
- Scale: 648mm/25.5"
- Color: GCM (Gray Chameleon)

Muhammed Suiçmez
Necrophagist

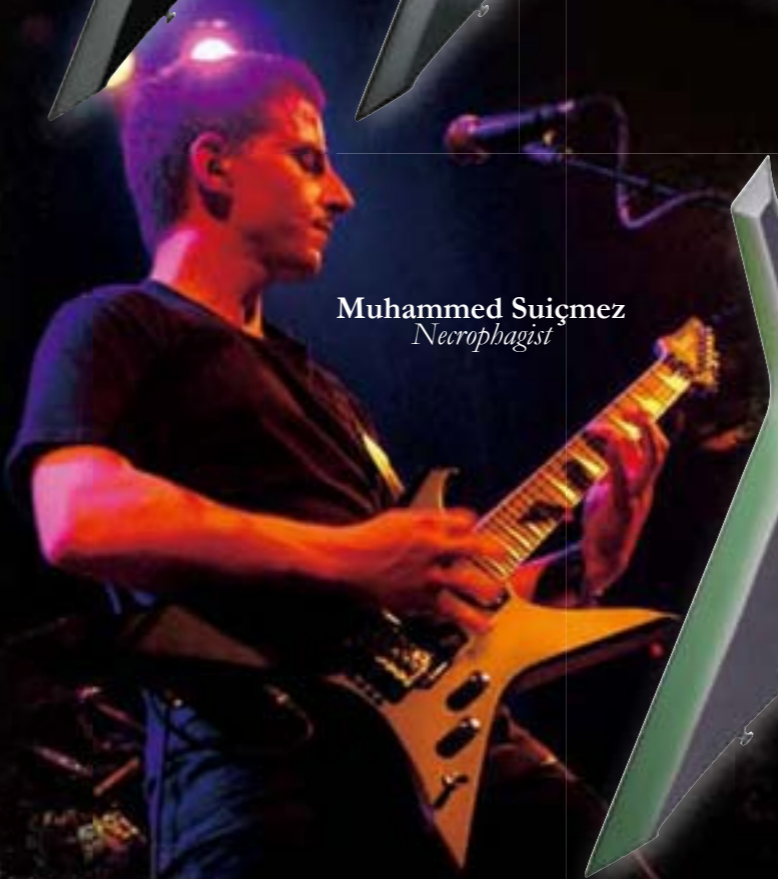

Terji Skibenæs
Tjör



AR *Prestige*

ARTIST

CRAFTED BY JAPAN'S FINEST LUTHIERS

The AR is a classic among Ibanez guitars. It was one of the first original designs produced by Ibanez and continues to be a sought after guitar. The AR300 continues that legacy with pride.

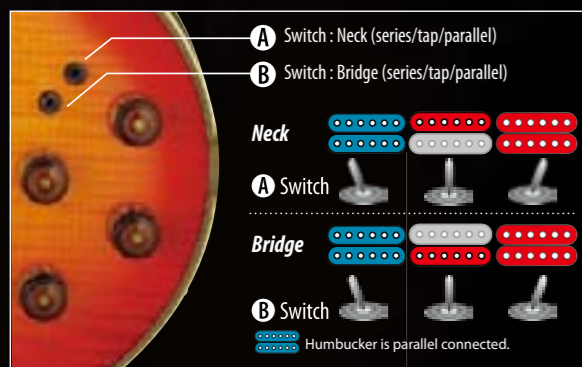

TRI-SOUND SWITCH

The AR300RE's original Tri-Sound switching system offers the choice of standard humbucking, single coil, or parallel humbucking sounds through the mini switches. Combined with the regular pickup selector, 15 distinct tone settings are available at your fingertips.



AR300RE CS

- 3pc AR Maple set-in neck *Prestige*
- Flamed Maple top/Mahogany body
- Medium frets
- Gibraltar bridge w/Sustain Block
- Quik Change tailpiece
- Super 58 (H) neck pu
- Super 58 (H) bridge pu
- Hardware color : Gold
- Scale : 628mm/24.75"
- Color : CS (Cherry Sunburst)

ART

Simple and effective, the ART is a classic single-cutaway guitar that was built for modern metal. The mahogany body is capable of producing the warm tones of yesterday, while the active low-impedance pickups can handle massive volume levels with very little noise.



AUTO TRIM TUNER OF ART600

Smart design cuts the excess string after you re-string and tune up – no extra cutting tool needed.

Barry Stock
Three Days Grace



TIGHT-TUNE BRIDGE & TAILPIECE

Solid as a rock, the Tight-Tune bridge and tailpiece were designed to lock down securely and prevent any kind of wobble or movement. Each saddle is locked into the base plate, and the bridge is anchored by stud bolts into the guitar body. Studs are also locked onto the base plate for maximum transfer of string vibration to the body.



SINGLE CUTAWAY & TRADITIONAL NECK HEEL

Sleek, classic cutaway and neck heel style.



ART600 TK

- 3pc ART Sapele/Maple set-in neck
- Quilted Maple top/Sapele body
- Medium frets
- Tight-Tune bridge
- Tight-Tune tailpiece
- LZ1-N (H) neck pu
- LZ1-B (H) bridge pu
- Hardware color : Cosmo Black
- Scale : 628mm/24.75"
- Colors : RNB (Rapid Night Blue)
TK (Transparent Black)



ART600 RNB

- 3pc ART Sapele/Maple set-in neck
- Quilted Maple top/Sapele body
- Medium frets
- Tight-Tune bridge
- Tight-Tune tailpiece
- LZ1-N (H) neck pu
- LZ1-B (H) bridge pu
- Hardware color : Cosmo Black
- Scale : 628mm/24.75"
- Colors : RNB (Rapid Night Blue)
TK (Transparent Black)



ART320 BLS

- 1pc ART Mahogany set-in neck
- Flamed Maple top/Mahogany body
- Medium frets
- Gibraltar III bridge
- Quik Change III tailpiece
- LZ1-N (H) neck pu
- LZ1-B (H) bridge pu
- Hardware color: Cosmo Black
- Scale: 628mm/24.75"
- Colors: BB (Blackberry)
BLS (Blue Sunburst)



ART320 BB

- 1pc ART Mahogany set-in neck
- Flamed Maple top/Mahogany body
- Medium frets
- Gibraltar III bridge
- Quik Change III tailpiece
- LZ1-N (H) neck pu
- LZ1-B (H) bridge pu
- Hardware color: Cosmo Black
- Scale: 628mm/24.75"
- Colors: BB (Blackberry)
BLS (Blue Sunburst)

ART

Nick Hipa
As I Lay Dying



ART420 HAM

- 1pc ART Mahogany set-in neck
- Spalted Maple top/Mahogany body
- Medium frets
- Gibraltar III bridge
- Quik Change III tailpiece
- LZ1-N (H) neck pu
- LZ1-B (H) bridge pu
- Hardware color: Cosmo Black
- Scale: 628mm/24.75"
- Color: HAM (Honey Amber)

ART



ART300 BNC

- 1pc ART Mahogany set-in neck
- Scalloped-Texture Maple top /Mahogany body
- Medium frets
- Gibraltar III bridge
- Quik Change III tailpiece
- LZ1-N (H) neck pu
- LZ1-B (H) bridge pu
- Hardware color: Cosmo Black
- Scale: 628mm/24.75"
- Colors: BNC (Brown Caiman)
BKC (Black Caiman)

ART300 BKC

- 1pc ART Mahogany set-in neck
- Scalloped-Texture Maple top /Mahogany body
- Medium frets
- Gibraltar III bridge
- Quik Change III tailpiece
- LZ1-N (H) neck pu
- LZ1-B (H) bridge pu
- Hardware color: Cosmo Black
- Scale: 628mm/24.75"
- Colors: BNC (Brown Caiman)
BKC (Black Caiman)

ARX

The ARX takes the tradition of the AR series and brings it into the present. Its slimmer body design and neck are a modern approach to this classic guitar style. Double-cutaway design for easy access to the uppermost frets, and a Quik Change III tailpiece that enhances the mahogany body's already powerful sustain.



ARX320 TCR

- 1pc ARX Mahogany set-in neck
- Quilted Maple top/Mahogany body
- Medium frets
- Gibraltar III bridge
- Quik Change III tailpiece
- ACH1-S (H) neck pu
- ACH2-S (H) bridge pu
- Hardware color: Chrome
- Scale: 628mm/24.75"
- Colors: TCR (Transparent Cherry)
TKS (Transparent Black Sunburst)

ARX320 TKS

- 1pc ARX Mahogany set-in neck
- Quilted Maple top/Mahogany body
- Medium frets
- Gibraltar III bridge
- Quik Change III tailpiece
- ACH1-S (H) neck pu
- ACH2-S (H) bridge pu
- Hardware color: Chrome
- Scale: 628mm/24.75"
- Colors: TCR (Transparent Cherry)
TKS (Transparent Black Sunburst)

ART

Roger Sjunnesson
Sonic Syndicate



ART100 SBF

- 1pc ART Mahogany set-in neck
- Maple top/Mahogany body
- Medium frets
- Gibraltar III bridge
- Quik Change III tailpiece
- ACH1-S (H) neck pu
- ACH2-S (H) bridge pu
- Hardware color : Chrome
- Scale : 628mm/24.75"
- Colors : BK (Black)
- TCR (Transparent Cherry)
- WH (White)
- GD (Gold)
- SBF (Satellite Blue Flat)



ART100 BK

- 1pc ART Mahogany set-in neck
- Maple top/Mahogany body
- Medium frets
- Gibraltar III bridge
- Quik Change III tailpiece
- ACH1-S (H) neck pu
- ACH2-S (H) bridge pu
- Hardware color : Chrome
- Scale : 628mm/24.75"
- Colors : BK (Black)
- TCR (Transparent Cherry)
- WH (White)
- GD (Gold)
- SBF (Satellite Blue Flat)



ART100 GD

- 1pc ART Mahogany set-in neck
- Maple top/Mahogany body
- Medium frets
- Gibraltar III bridge
- Quik Change III tailpiece
- ACH1-S (H) neck pu
- ACH2-S (H) bridge pu
- Hardware color : Chrome
- Scale : 628mm/24.75"
- Colors : BK (Black)
- TCR (Transparent Cherry)
- WH (White)
- GD (Gold)
- SBF (Satellite Blue Flat)



ART100 TCR

- 1pc ART Mahogany set-in neck
- Maple top/Mahogany body
- Medium frets
- Gibraltar III bridge
- Quik Change III tailpiece
- ACH1-S (H) neck pu
- ACH2-S (H) bridge pu
- Hardware color : Chrome
- Scale : 628mm/24.75"
- Colors : BK (Black)
- TCR (Transparent Cherry)
- WH (White)
- GD (Gold)
- SBF (Satellite Blue Flat)



ART100 WH

- 1pc ART Mahogany set-in neck
- Maple top/Mahogany body
- Medium frets
- Gibraltar III bridge
- Quik Change III tailpiece
- ACH1-S (H) neck pu
- ACH2-S (H) bridge pu
- Hardware color : Chrome
- Scale : 628mm/24.75"
- Colors : BK (Black)
- TCR (Transparent Cherry)
- WH (White)
- GD (Gold)
- SBF (Satellite Blue Flat)



ART100 BKL

- 1pc ART Mahogany set-in neck
- Maple top/Mahogany body
- Medium frets
- Gibraltar III bridge
- Quik Change III tailpiece
- ACH1-S (H) neck pu
- ACH2-S (H) bridge pu
- Hardware color : Chrome
- Scale : 628mm/24.75"
- Color : BK (Black)

Matt Roberts
3 Doors Down

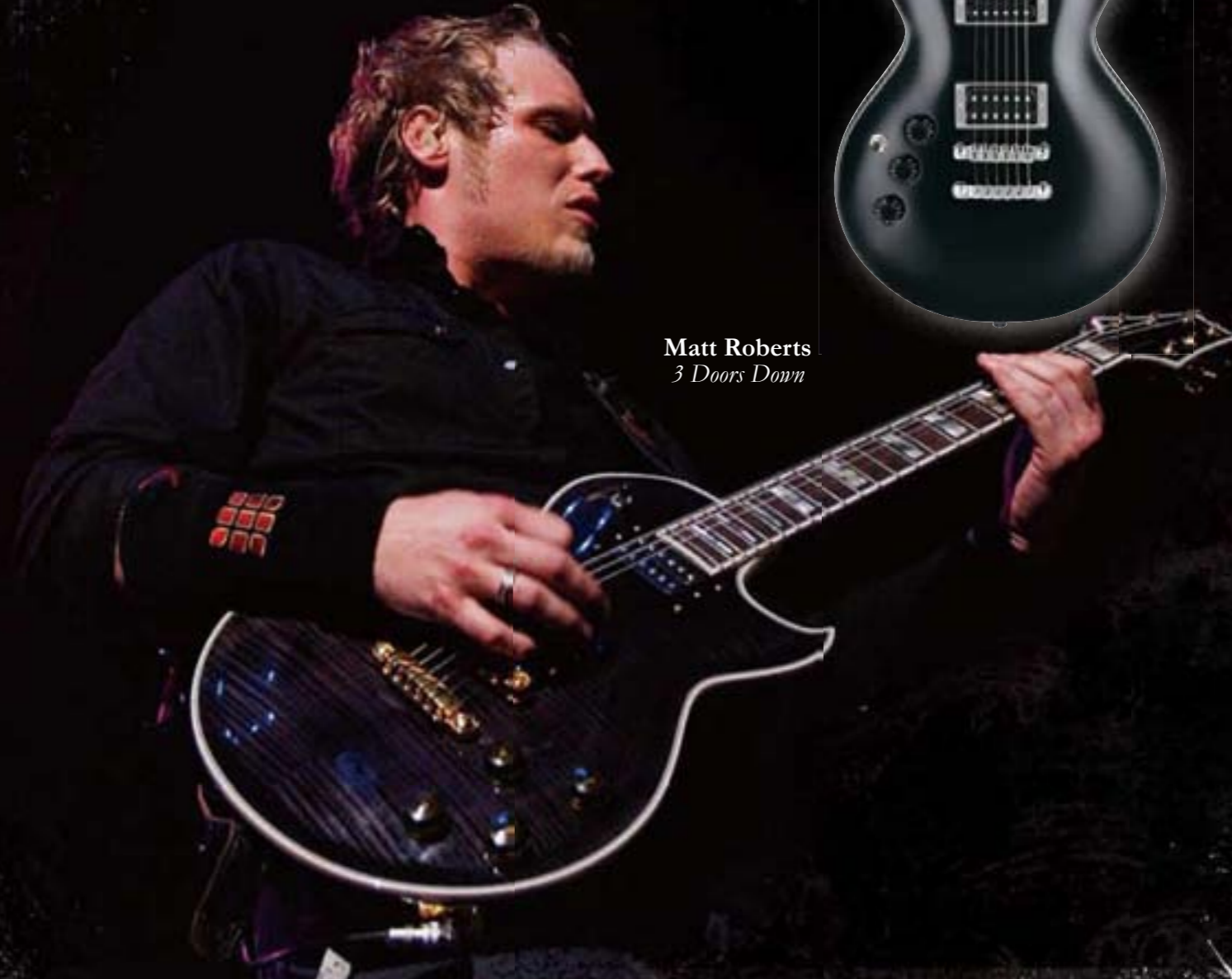

GART

Sean Kipe
Course of Nature



GART30 TR

- 1pc GART Maple neck
- Basswood body
- Medium frets
- Fixed bridge
- PSND1 (H) neck pu
- PSND2 (H) bridge pu
- Hardware color : Chrome
- Scale : 628mm/24.75"
- Colors : BKN (Black Night)
JB (Jewel Blue)
TR (Transparent Red)

GART30 JB

- 1pc GART Maple neck
- Basswood body
- Medium frets
- Fixed bridge
- PSND1 (H) neck pu
- PSND2 (H) bridge pu
- Hardware color : Chrome
- Scale : 628mm/24.75"
- Colors : BKN (Black Night)
JB (Jewel Blue)
TR (Transparent Red)

GART30 BKNL

- 1pc GART Maple neck
- Basswood body
- Medium frets
- Fixed bridge
- PSND1 (H) neck pu
- PSND2 (H) bridge pu
- Hardware color : Chrome
- Scale : 628mm/24.75"
- Colors : BKN (Black Night)



GART50QA TRB

- 1pc GART Maple neck
- Quilted Maple Art Grain top /Basswood body
- Medium frets
- Fixed bridge
- PSND1 (H) neck pu
- PSND2 (H) bridge pu
- Hardware color : Chrome
- Scale : 628mm/24.75"
- Colors : TRB (Transparent Red Burst)
TKS (Transparent Black Sunburst)

GART50QA TKS

- 1pc GART Maple neck
- Quilted Maple Art Grain top /Basswood body
- Medium frets
- Fixed bridge
- PSND1 (H) neck pu
- PSND2 (H) bridge pu
- Hardware color : Chrome
- Scale : 628mm/24.75"
- Colors : TRB (Transparent Red Burst)
TKS (Transparent Black Sunburst)

GART50FA TKS

- 1pc GART Maple neck
- Flamed Maple Art Grain top /Basswood body
- Medium frets
- Fixed bridge
- PSND1 (H) neck pu
- PSND2 (H) bridge pu
- Hardware color : Chrome
- Scale : 628mm/24.75"
- Color : TKS (Transparent Black Sunburst)

Gizz Butt
The More I See
Photo by Nigel Crane



Tobias Buck
Neera



Stefan Keller
Neera

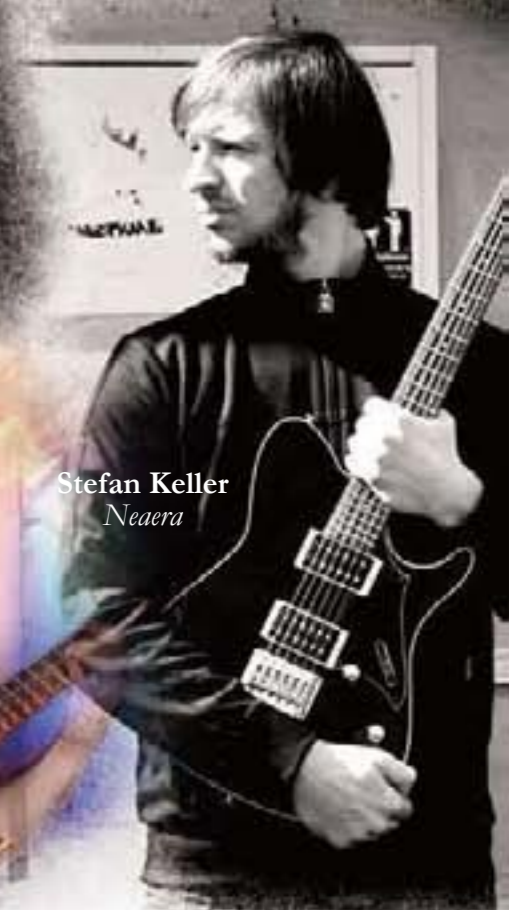

Peter Goemaere



FR1620 RDO

- 5pc Wizard HP Maple /Walnut neck *Prestige*
- Ash body
- Jumbo frets
- Tight-End bridge
- CCR1 (H) neck pu
- CCR2 (H) bridge pu
- Hardware color : Chrome
- Scale : 648mm/25.5"
- Colors : BK (Black)
RDO (Red Optimus)

FR1620 BK

- 5pc Wizard HP Maple /Walnut neck *Prestige*
- Ash body
- Jumbo frets
- Tight-End bridge
- CCR1 (H) neck pu
- CCR2 (H) bridge pu
- Hardware color : Chrome
- Scale : 648mm/25.5"
- Colors : BK (Black)
RDO (Red Optimus)

FR *Prestige*

CRAFTED BY JAPAN'S FINEST LUTHIERS

The FR first appeared in 2008. With a simple and uncompromising design, the FR is a chameleon when it comes to musical genres. The ash body brings more punch to the midrange tones, while the Tight-End bridge provides maximum string vibration and playing comfort.



TIGHT-END BRIDGE

The Tight-End bridge integrates every aspect of the bridge design in rigidity and accuracy. Saddles are firmly locked onto the base plate for maximum string vibration, and remain perfectly linear during intonation adjustment for the most accurate set up. The saddle height can be adjusted individually by one screw. Also, the top side of the bridge is smooth finished. So if you play hard, the Tight-End bridge will forgive you and your hands.



Andreas Gerhard
Aloha from Hell

Rob Daniels
Jimmy Wayne Band



SV5470F NBL

- 5pc Wizard HP Maple /Walnut neck *Prestige*
- Flamed Maple top/Mahogany body
- Jumbo frets
- SynchroniZR bridge w/ZPS-FX
- TDB2 (H) neck pu
- ST2 (S) mid pu
- TDB3 (H) bridge pu
- Hardware color : Cosmo Black
- Scale : 648mm/25.5"
- Colors : DSB (Dark Sunset Burst) NBL (Natural Blue)

SV5470F DSB

- 5pc Wizard HP Maple /Walnut neck *Prestige*
- Flamed Maple top/Mahogany body
- Jumbo frets
- SynchroniZR bridge w/ZPS-FX
- TDB2 (H) neck pu
- ST2 (S) mid pu
- TDB3 (H) bridge pu
- Hardware color : Cosmo Black
- Scale : 648mm/25.5"
- Colors : DSB (Dark Sunset Burst) NBL (Natural Blue)

SV *Prestige*

CRAFTED BY JAPAN'S FINEST LUTHIERS

The S series has long been admired for its design, but some players prefer the simplicity of a non-locking tremolo. The SV was created to satisfy the professional player, who wants a more versatile solution. The SynchroniZR non-locking tremolo uses the same smooth ball bearing mechanisms that have made the ZR bridge so popular. The SV also comes equipped with the Tru-Duo pickup system for superior tonal variety from the single coil and humbucker universe.

H-S-H (w/True-Duo Blast)

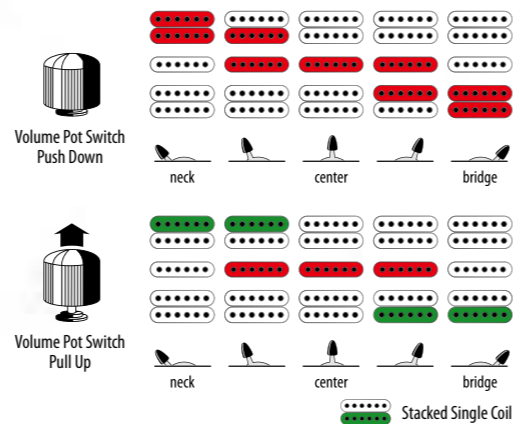

TRUE-DUO™ SINGLE COIL/HUMBUCKER SWITCHING SYSTEM

There have been lots of attempts and claims, but the new True-Duo™ is the genuine article – the first system that really provides both genuine glassy single-coil tones and rich, beefy humbucking tones in one pickup. After a lot of research and experimentation, Ibanez's musician/engineers came up with an ingenious triple coil pickup that finally does the job.



SYNCHRONIZR TREMOLO

The SynchroniZR provides all the innovations of the ZR tremolo in a non-locking design. The one-piece saddle construction minimizes unnecessary wobble and loss of string vibration, and the ultra-light Duralumin tremolo arm keeps the bridge stable while playing. The same intonation and adjustment features of the ZR-2 make this a top-notch choice for any kind of player.

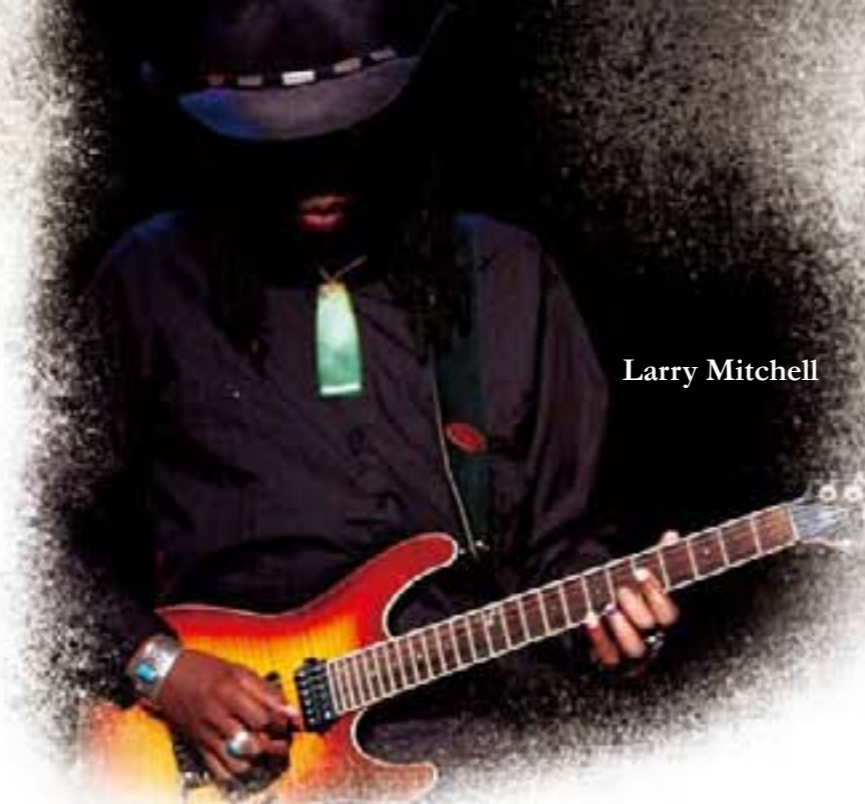

Larry Mitchell



SA260FM BBS

- 3pc SA Maple neck
- Flamed Maple top/Mahogany body
- Medium frets
- SAT Pro II bridge
- AH51 (S) neck pu
- AH52 (S) mid pu
- True-Duo Bucker (H) bridge pu
- Hardware color : Chrome
- Scale : 648mm/25.5"
- Color : BBS (Blackberry Sunburst)

SA

You want versatility? The SA adapts to any genre of music for clean rhythm, crunchy blues or even hard-driving riffs and solos. It also offers a variety of looks such as metal-like solid colors or traditional wooden finishes. The SA also makes use of the same Tru-Duo pickup system available on the SV models and the abundant resonance of the SAT-Pro tremolo.



SA120 BK

- 3pc SA Maple neck
- Mahogany body
- Medium frets
- SAT Pro II bridge
- AH5 (H) neck pu
- AH6 (H) bridge pu
- Hardware color : Chrome
- Scale : 648mm/25.5"
- Colors : BK (Black) CN (Charcoal Brown)

SA120 CN

- 3pc SA Maple neck
- Mahogany body
- Medium frets
- SAT Pro II bridge
- AH5 (H) neck pu
- AH6 (H) bridge pu
- Hardware color : Chrome
- Scale : 648mm/25.5"
- Colors : BK (Black) CN (Charcoal Brown)

GSA60 JB

- 1pc GSA Maple neck
- Agathis body
- Medium frets
- SAT10 bridge
- PSNDS (S) neck pu
- PSNDS (S) mid pu
- PSND2 (H) bridge pu
- Hardware color : Chrome
- Scale : 648mm/25.5"
- Colors : JB (Jewel Blue) BKN (Black Night)

S-S-H (w/True-Duo Bucker)

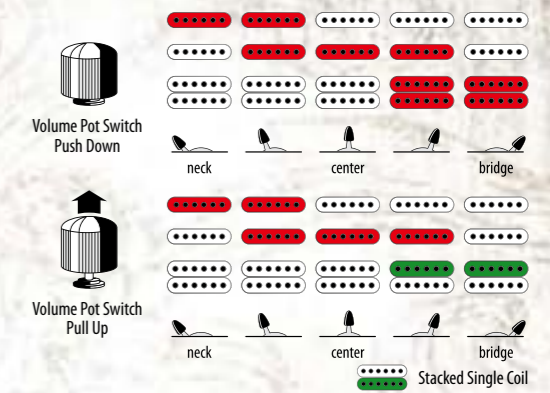

TRUE-DUO™ PICK-UPS

SAS32 models are the first Ibanez guitars to offer True-Duo pickups in dual humbucker configuration.

THE MARS VOLTA

Omar Rodriguez-Lopez SIGNATURE MODEL

Created with traditional looks in mind, this guitar had to excel in just about any situation to work in The Mars Volta. If anyone knows how to push a guitar to its limits, it's Omar Rodriguez-Lopez. The white finish ORM1WH passes every test.

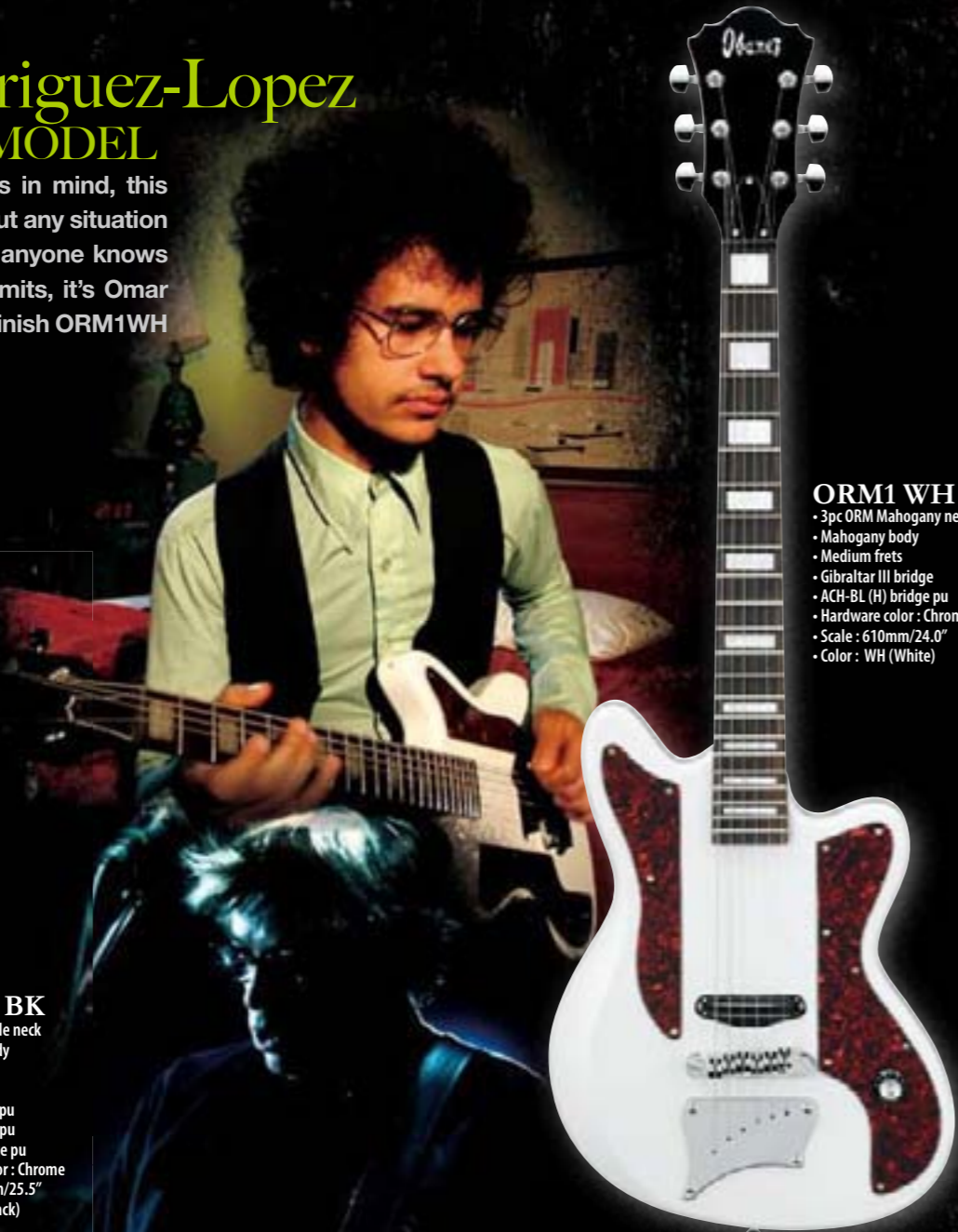

- ORM1 WH**
- 3pc ORM Mahogany neck
 - Mahogany body
 - Medium frets
 - Gibraltar III bridge
 - ACH-BL (H) bridge pu
 - Hardware color : Chrome
 - Scale : 610mm/24.0"
 - Color : WH (White)



- NDM2 BK**
- 3pc NDM Maple neck
 - Basswood body
 - Large frets
 - Fixed bridge
 - INF1 (H) neck pu
 - INF1 (S) mid pu
 - INF2 (H) bridge pu
 - Hardware color : Chrome
 - Scale : 648mm/25.5"
 - Color : BK (Black)

THE OFFSPRING Noodles SIGNATURE MODEL

Born from punk rock attitude but built for all things aggressive. The NDM's mirrored skull Offspring emblem says it all – Flaming Death or Glory! Noodles' Signature NDM2BK is an all-purpose rock axe that can fit into any mix.

JTK JET KING

Some people never forget that first prized guitar that they found at the local pawnshop, and with the JTK they'll never have to. The Jet King takes all the retro styling of a vintage guitar and couples it with solid, modern hardware. Ibanez also developed original low-noise pickups for the Jet King that reproduce the old-school look and sound of soap bar pickups.



Rob Patterson
Dr.Z

Andy Jackson
Hot Rod Circuit

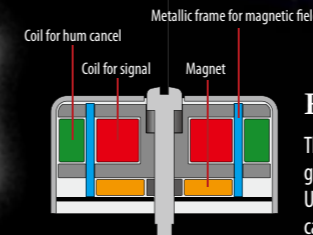

HFS PICKUPS

The HFS PU looks like a vintage single coil at first glance, but looks can be deceiving. Underneath, the HFS makes use of a separate coil to cancel any hum or noise generated by the single coil.



- JTK30 BSV**
- 3pc JTK Maple neck
 - Mahogany body
 - Medium frets
 - Full Tune III bridge
 - HFS1 (S) neck pu
 - HFS2 (S) bridge pu
 - Hardware color : Chrome
 - Scale : 648mm/25.5"
 - Colors : BTN(Blue Stone)
TQ (Turquoise)
BSV (Brilliant Silver)



- JTK30 BTN**
- 3pc JTK Maple neck
 - Mahogany body
 - Medium frets
 - Full Tune III bridge
 - HFS1 (S) neck pu
 - HFS2 (S) bridge pu
 - Hardware color : Chrome
 - Scale : 648mm/25.5"
 - Colors : BTN(Blue Stone)
TQ (Turquoise)
BSV (Brilliant Silver)



- JTK30 TQ**
- 3pc JTK Maple neck
 - Mahogany body
 - Medium frets
 - Full Tune III bridge
 - HFS1 (S) neck pu
 - HFS2 (S) bridge pu
 - Hardware color : Chrome
 - Scale : 648mm/25.5"
 - Colors : BTN(Blue Stone)
TQ (Turquoise)
BSV (Brilliant Silver)



- JTK40 RD**
- 3pc JTK Maple neck
 - Mahogany body
 - Medium frets
 - Full Tune III bridge w/ Roller Saddle
 - VBX60 vibrato
 - ACH3 (H) neck pu
 - ACH4 (H) bridge pu
 - Hardware color : Chrome
 - Scale : 648mm/25.5"
 - Color : RD (Red)

Jumpstart

When we say “Everything you need to get out and gig,” we mean everything — amp, axe, accessories. All it takes is you and your desire to make your dreams real to get out of the audience and up on stage where you belong.



IJX121 -Jumpstart-

Features GRG121EX electric guitar and Jumpstart guitar Package Accessories.

Amplifier

15 watt dedicated guitar amp w/reverb

Package Accessories

- Headphones
- Electronic Tuner
- Gig Bag
- Guitar Strap
- Picks
- Cable
- Chord Chart Poster
- Accessories Pouch

GRG121EX BKN



GRX40 MR

GRX40 JB

GRX40 BKN

IJX40 -Jumpstart-

Features GRX40 electric guitar and Jumpstart guitar Package Accessories.

Amplifier

15 watt dedicated guitar amp w/reverb

Package Accessories

- Headphones
- Electronic Tuner
- Gig Bag
- Guitar Strap
- Picks
- Cable
- Chord Chart Poster
- Accessories Pouch



IJX20 -Jumpstart-

Features GRX20 electric guitar and Jumpstart Guitar Package Accessories.

Amplifier

10 watt dedicated guitar amp

Package Accessories

- Electronic Tuner
- Gig Bag
- Guitar Strap
- Picks
- Cable



GRX20 BKN



Full & Semi-Acoustic Electric Guitars

Over the past decade, we've continually refined our Artcore series of full and semi-hollow guitars. Our luthiers have designed and refined exquisite signature models for jazz giants George Benson, Pat Metheny, and John Scofield—in addition to unveiling the Artcore Custom series. In 2010, one question still remains: How can we continue to enhance and add high end appointments to these instruments and still offer them at such affordable prices?

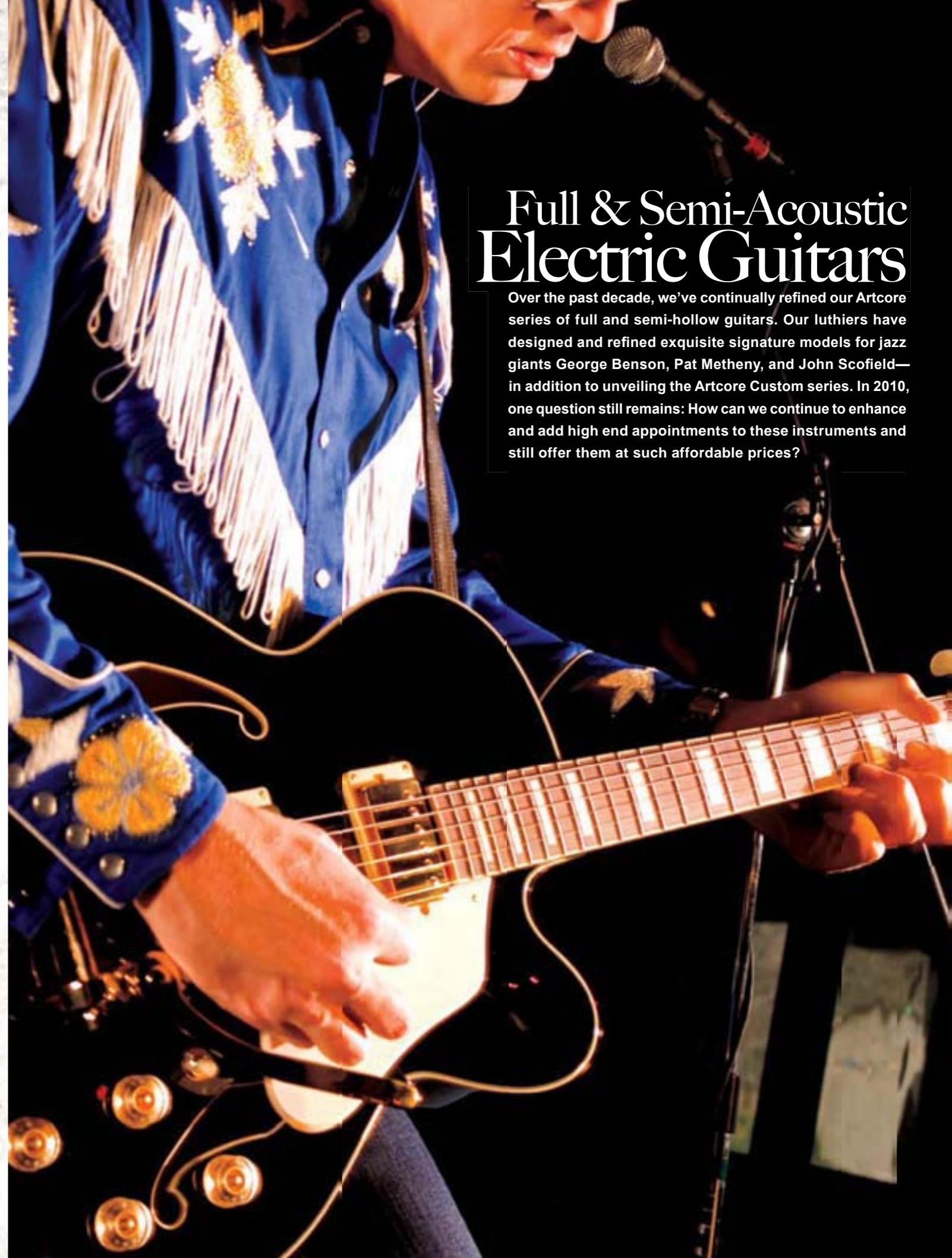

George Benson SIGNATURE MODELS

George Benson's taste, tone, bluesy phrasing and incomparable sense of swing has ensured his place in the history of jazz guitar. Ibanez is extremely proud of our long and fruitful relationship, now celebrating over 30 years of collaboration. The GB models are some of the finest jazz guitars on the market today.

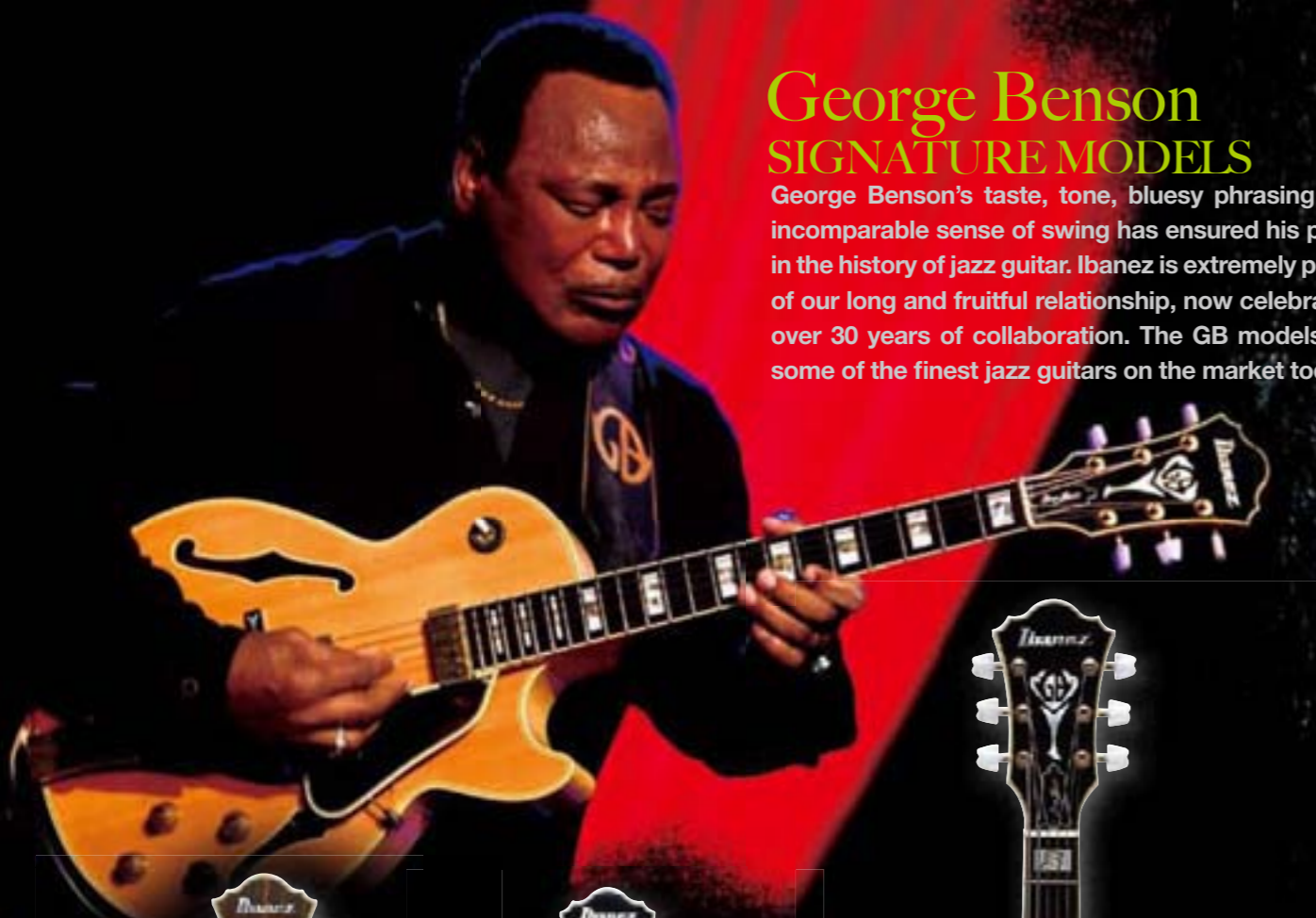

GB200 BS

- 3pc GB Mahogany/Maple set-in neck *Prestige*
- Spruce top/Maple back/sides
- Medium frets
- Ebony bridge
- GB200 tailpiece
- Super 58 (H) neck pu
- Super 58 (H) bridge pu
- Hardware color : Gold
- Scale : 628mm/24.75"
- Depth : 80mm at tail
- Color : BS (Brown Sunburst)



GB15 TR

- 3pc GB15 Maple set-in neck *Prestige*
- Spruce top/Maple back/sides
- Medium frets
- Ebony bridge
- GB15 tailpiece
- GB special (H) neck pu
- Hardware color : Cosmo Black
- Scale : 628mm/24.75"
- Depth : 75mm at tail
- Color : TR (Transparent Red)



GB10 NT

- 3pc GB Maple set-in neck *Prestige*
- Spruce top/Maple back/sides
- Medium frets
- Ebony bridge
- GB10 tailpiece
- GB special (H) neck pu
- GB special (H) bridge pu
- Hardware color : Gold
- Scale : 628mm/24.75"
- Depth : 65mm at tail
- Colors : NT (Natural)
BS (Brown Sunburst)

Pat Metheny SIGNATURE MODELS

An Ibanez Signature artist since 1996, Pat's adventurous forays into jazz, pop, folk and Latin music have enthralled audiences all over the world. At the core of these journeys are, of course, Pat's sumptuous guitar playing and his Ibanez Signature instruments.



PM35 NT

- 5pc PM Maple/Walnut set-in neck
- Maple top/back/sides
- Medium frets
- ART-1 bridge
- KT30 tailpiece
- Super 58 Custom (H) neck pu
- Hardware color : Gold
- Scale : 628mm/24.75"
- Depth : 70mm at tail
- Color : NT (Natural)

PM100 BK

- PM Mahogany set-in neck *Prestige*
- Maple top/back/sides
- Medium frets
- Gotoh®103B bridge
- PM tailpiece
- Super 58 (H) neck pu
- Hardware color : Gold
- Scale : 628mm/24.75"
- Depth : 80mm at tail
- Color : BK (Black)

PM120 NT

- PM Mahogany set-in neck *Prestige*
- Maple top/back/sides
- Medium frets
- Gotoh®103B bridge
- PM tailpiece
- Silent 58 (H) neck pu
- Silent 58 (H) bridge pu
- Hardware color : Gold
- Scale : 628mm/24.75"
- Depth : 50mm at tail
- Colors : NT (Natural)
BK (Black)



JSM100 VT

- JSM Mahogany set-in neck *Prestige*
- Flamed Maple top/Maple back/sides
- Jumbo frets
- Gotoh®510BN bridge
- Quik Change II tailpiece
- Super 58 (H) neck pu
- Super 58 (H) bridge pu
- Hardware color : Gold
- Scale : 628mm/24.75"
- Depth : 43mm at tail
- Color : VT (Vintage Sunburst)

John Scofield SIGNATURE MODEL

Guitarist John Scofield has blazed a fearless trail, moving effortlessly in and out of bop, fusion, rock, funk, blues and soul. Since becoming an Ibanez Signature artist in 2001, John's trusted JSM100 has been at the ready, waiting for the next adventurous musical turn in the road.

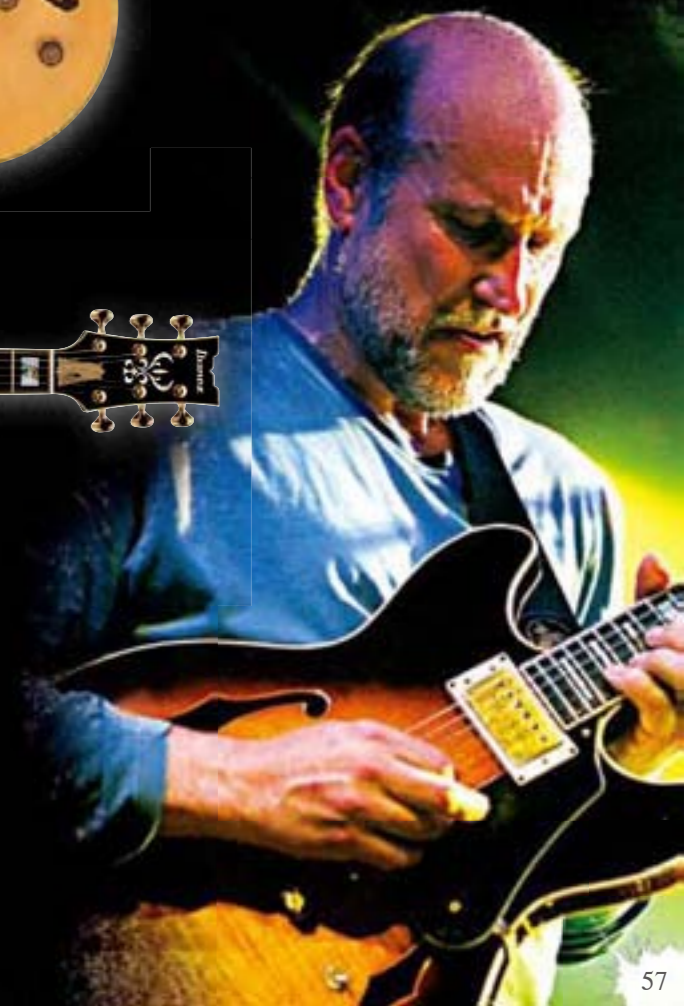
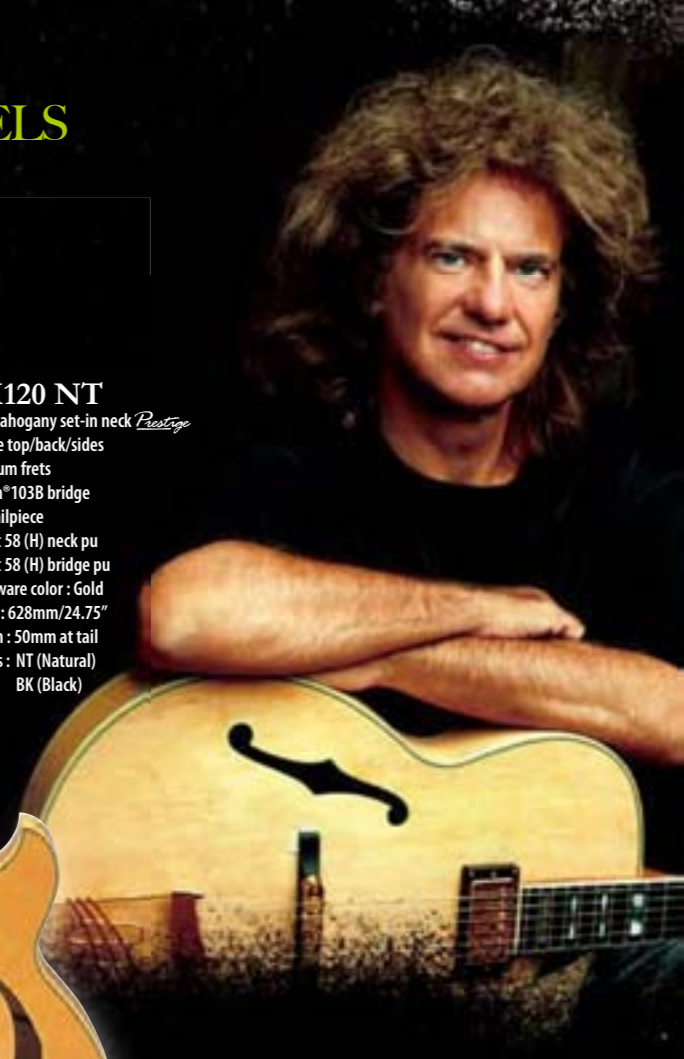

ARTCORE

The Artcore line represents a step forward in the evolution of affordable hollow body guitars. Since 2002, Ibanez has been producing these exquisite guitars that are at home in a jazz combo as well as a full-on rock show. Like many other Ibanez models, the Artcores are as versatile as they are beautiful. They come in a variety of sizes and hardware configurations to meet the needs of the one at a price fit for all.

AF/ASCUSTOM

The Artcore Custom is the flagship of the Artcore series. Beautiful maple body and maple / walnut set-in neck construction producing warm and punch tone. Wood control knobs and matching pickguard enhance the exquisite appearance of the Artcore Custom.

AS103 VB

- 5pc Artcore Maple/Walnut set-in neck
- Flamed Maple top/back/sides
- Medium frets
- ART-1 bridge
- Quik Change III tailpiece
- Super 58 Custom (H) neck pu
- Super 58 Custom (H) bridge pu
- Hardware color : Gold
- Scale : 628mm/24.75"
- depth : 43mm at tail
- Color : VB (Vintage Burst)



AF105 NT

- 5pc Artcore Maple/Walnut set-in neck
- Flamed Maple top/back/sides
- Medium frets
- ART-1 bridge
- VT04 Custom tailpiece
- Super 58 Custom (H) neck pu
- Super 58 Custom (H) bridge pu
- Hardware color : Gold
- Scale : 628mm/24.75"
- depth : 70mm at tail
- Color : NT (Natural)



AF125 AMB

- 5pc Artcore Maple/Walnut set-in neck
- Quilted Maple top/back/sides
- Medium frets
- ART-1 bridge
- VT04 Custom tailpiece
- Super 58 Custom (H) neck pu
- Super 58 Custom (H) bridge pu
- Hardware color : Gold
- Scale : 628mm/24.75"
- depth : 70mm at tail
- Color : AMB (Amber Burst)



AK

Jazz and blues history is filled with the warm tones of large hollow body guitars. The AK escapes from the bright sound of maple tops and metal bridges, replacing them with a spruce top and an all-wood bridge.

AK80 BS

- 3pc Artcore Mahogany/Maple set-in neck
- Spruce top/Flamed Maple back & sides
- Medium frets
- ART-W wooden bridge
- VT60 tailpiece
- ACH1 (H) neck pu
- ACH2 (H) bridge pu
- Hardware color : Chrome
- Scale : 628mm/24.75"
- depth : 70mm at tail
- Color : BS (Brown Sunburst)



AK95 DVS

- 3pc Artcore Mahogany/Maple set-in neck
- Spruce top/Flamed Maple back & sides
- Medium frets
- ART-W wooden bridge
- VT100DX tailpiece
- ACH1 (H) neck pu
- ACH2 (H) bridge pu
- Hardware color : Gold
- Scale : 628mm/24.75"
- depth : 70mm at tail
- Color : DVS (Dark Violin Sunburst)



AK 20-FRET – WARMER TONE THAN 22-FRET

A traditional 20-fret fingerboard is combined with just the right placement of the neck pickup, for (more traditional) warmer tone.



U-Nam



AF

The AF is the most traditional of the Artcore series. The traditional full-hollow construction means there are no sound blocks in the body. Producing rich and complex tones, the AF is the guitar for the purist in all of us.

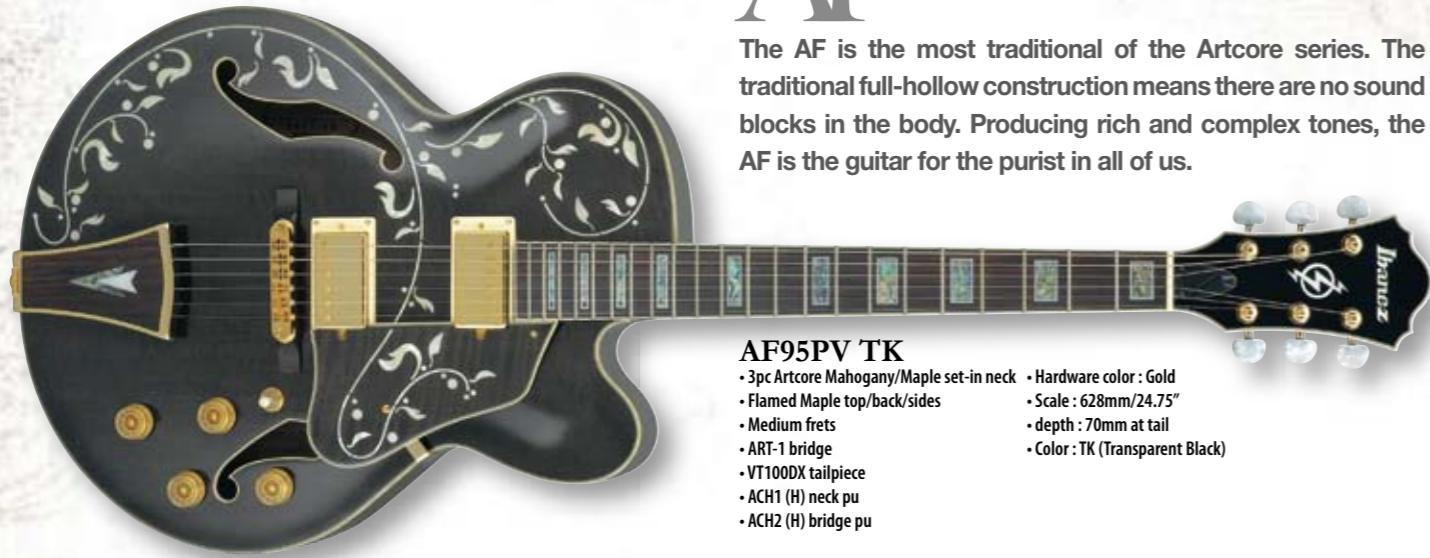

AF95PV TK

- 3pc Artcore Mahogany/Maple set-in neck
- Flamed Maple top/back/sides
- Medium frets
- ART-1 bridge
- VT100DX tailpiece
- ACH1 (H) neck pu
- ACH2 (H) bridge pu
- Hardware color : Gold
- Scale : 628mm/24.75"
- depth : 70mm at tail
- Color : TK (Transparent Black)



BODY THICKNESS: AF VS. AFS

The AFS body also features full-hollow construction, offering midrange punch, (remove) Smoky jazz, retro twang, rocking blues, swinging country are all inside of AFS.

AFS

Pushing traditional concepts one step further, the Ibanez AFS has the same shape and full-hollow body of the AF. For increased comfort and more midrange punch, the body depth is one inch thinner. An Ibanez Vintage Vibrato is also mounted on the body with roller saddles, eliminating the tuning problems of traditional systems.



AF75 TRS

AF75 TRS

- Artcore Mahogany set-in neck
- Maple top/back/sides
- Medium frets
- ART-1 bridge
- VT60 tailpiece
- ACH1 (H) neck pu
- ACH2 (H) bridge pu
- Hardware color : Chrome
- Scale : 628mm/24.75"
- depth : 70mm at tail
- Colors : BS (Brown Sunburst)
- TRS (Transparent Red Sunburst)



AF75 BS

- Artcore Mahogany set-in neck
- Maple top/back/sides
- Medium frets
- ART-1 bridge
- VT60 tailpiece
- ACH1 (H) neck pu
- ACH2 (H) bridge pu
- Hardware color : Chrome
- Scale : 628mm/24.75"
- depth : 70mm at tail
- Colors : BS (Brown Sunburst)
- TRS (Transparent Red Sunburst)



AF75D TOR

- Artcore Mahogany set-in neck
- Maple top/back/sides
- Medium frets
- ART-1 bridge
- VT60 tailpiece
- ACH1 (H) neck pu
- ACH2 (H) bridge pu
- Hardware color : Chrome
- Scale : 628mm/24.75"
- depth : 70mm at tail
- Color : TOR (Transparent Orange)



AF75TDG BK

- Artcore Mahogany set-in neck
- Maple top/back/sides
- Medium frets
- ART-2 Roller bridge
- VBF70 vibrato
- ACH1 (H) neck pu
- ACH2 (H) bridge pu
- Hardware color : Gold
- Scale : 628mm/24.75"
- depth : 70mm at tail
- Colors : IV (Ivory)
- BK (Black)



AF75TDG IV

- Artcore Mahogany set-in neck
- Maple top/back/sides
- Medium frets
- ART-2 Roller bridge
- VBF70 vibrato
- ACH1 (H) neck pu
- ACH2 (H) bridge pu
- Hardware color : Gold
- Scale : 628mm/24.75"
- depth : 70mm at tail
- Colors : IV (Ivory)
- BK (Black)



AFS75T TRD

- Artcore Mahogany set-in neck
- Maple top/back/sides
- Medium frets
- ART-2 Roller bridge
- VBF70 vibrato
- ACH1 (H) neck pu
- ACH2 (H) bridge pu
- Hardware color : Chrome
- Scale : 628mm/24.75"
- depth : 43mm at tail
- Colors : TRD (Transparent Red)
- NWB (Neo Western Black)



AFS75T NWB

- Artcore Mahogany set-in neck
- Maple top/back/sides
- Medium frets
- ART-2 Roller bridge
- VBF70 vibrato
- ACH1 (H) neck pu
- ACH2 (H) bridge pu
- Hardware color : Chrome
- Scale : 628mm/24.75"
- depth : 43mm at tail
- Colors : TRD (Transparent Red)
- NWB (Neo Western Black)



AG/AGS

The AG has a slightly smaller body width than the more traditional AF dimensions. However, the same depth and true full-hollow body construction make for a big standout sound.

The AGS has semi-hollow body and thinner body than AG for more comfort and playability.

Chris Camozzi
Michael Bolton



BODY THICKNESS: AG VS. AGS

The AGS body features a slimmer thickness along with the already compact AG size, for even more comfort and playability.



AG95 DBS

- 3pc Artcore Mahogany/Maple set-in neck
- Figured Bubinga top/back/sides
- Medium frets
- ART-1 bridge
- VT100DX tailpiece
- ACH1 (H) neck pu
- ACH2 (H) bridge pu
- Hardware color : Gold
- Scale : 628mm/24.75"
- depth : 70mm at tail
- Color : DBS (Dark Brown Sunburst)



AG75 BS

- Artcore Mahogany set-in neck
- Maple top/back/sides
- Medium frets
- ART-1 bridge
- VT60 tailpiece
- ACH1 (H) neck pu
- ACH2 (H) bridge pu
- Hardware color : Chrome
- Scale : 628mm/24.75"
- depth : 70mm at tail
- Color : BS (Brown Sunburst)



AGS83B ATF

- 3pc Artcore Mahogany/Maple set-in neck
- Flamed Maple top/back/sides
- Medium frets
- ART-1 bridge
- Quik Change III tailpiece
- ACH1 (H) neck pu
- ACH2 (H) bridge pu
- Hardware color : Cosmo Black
- Scale : 628mm/24.75"
- depth : 43mm at tail
- Color : ATF (Antique Burst Flat)



AS93PV TK

- 3pc Artcore Mahogany/Maple set-in neck
- Flamed Maple top/back/sides
- Medium frets
- ART-1 bridge
- Quik Change III tailpiece
- ACH1 (H) neck pu
- ACH2 (H) bridge pu
- Hardware color : Gold
- Scale : 628mm/24.75"
- depth : 43mm at tail
- Color : TK (Transparent Black)

AS

The AS is a semi-acoustic guitar built to tackle just about any genre of music you throw at it. The pickups are mounted into a sustain block for increased sustain and feedback elimination. The Quik Change III bridge makes it easy to change strings without a lot of time involved.

AS93 BLS

- 3pc Artcore Mahogany/Maple set-in neck
- Flamed Maple top/back/sides
- Medium frets
- ART-1 bridge
- Quik Change III tailpiece
- ACH1 (H) neck pu
- ACH2 (H) bridge pu
- Hardware color : Gold
- Scale : 628mm/24.75"
- depth : 43mm at tail
- Colors : BLS (Blue Sunburst)



Eric Krasno
Soulive



AS



AS73 IV

- Artcore Mahogany set-in neck
- Maple top/back/sides
- Medium frets
- ART-1 bridge
- Quik Change III tailpiece
- ACH1 (H) neck pu
- ACH2 (H) bridge pu
- Hardware color : Chrome
- Scale : 628mm/24.75"
- depth : 43mm at tail
- Colors : BS (Brown Sunburst)
IV (Ivory)
TCR (Transparent Cherry)



AS73 TCR

- Artcore Mahogany set-in neck
- Maple top/back/sides
- Medium frets
- ART-1 bridge
- Quik Change III tailpiece
- ACH1 (H) neck pu
- ACH2 (H) bridge pu
- Hardware color : Chrome
- Scale : 628mm/24.75"
- depth : 43mm at tail
- Colors : BS (Brown Sunburst)
IV (Ivory)
TCR (Transparent Cherry)



AS73 TCRL

- Artcore Mahogany set-in neck
- Maple top/back/sides
- Medium frets
- ART-1 bridge
- Quik Change III tailpiece
- ACH1 (H) neck pu
- ACH2 (H) bridge pu
- Hardware color : Chrome
- Scale : 628mm/24.75"
- depth : 43mm at tail
- Color : TCR (Transparent Cherry)



AS73B BKF

- Artcore Mahogany set-in neck
- Maple top/back/sides
- Medium frets
- ART-1 bridge
- Quik Change III tailpiece
- ACH1-S (H) neck pu
- ACH2-S (H) bridge pu
- Hardware color : Chrome
- Scale : 628mm/24.75"
- depth : 43mm at tail
- Color : BKF (Black Flat)

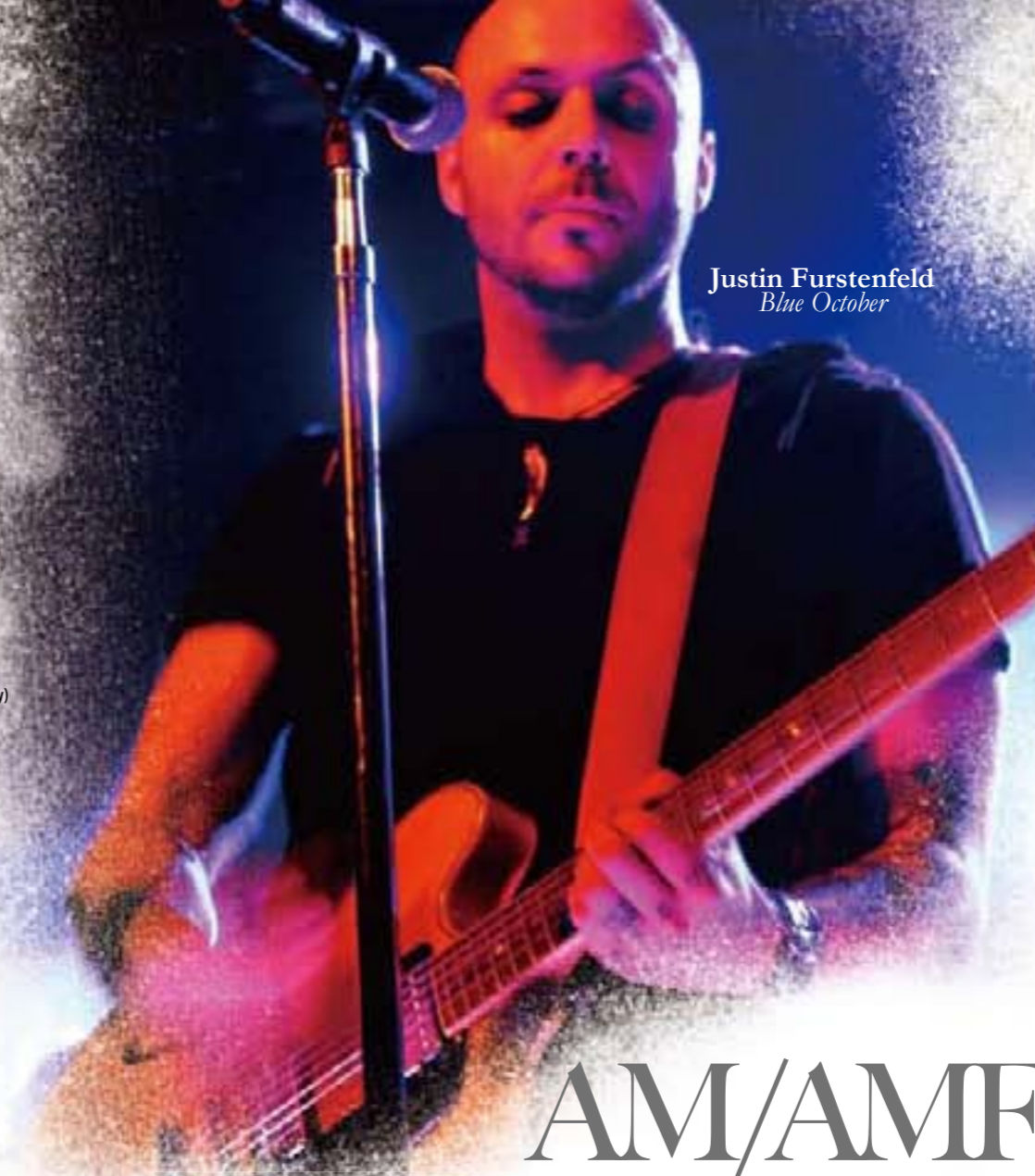

Justin Furstentfeld
Blue October



AM73B BKF

- Artcore Mahogany set-in neck
- Maple top/back/sides
- Medium frets
- ART-1 bridge
- Quik Change III tailpiece
- ACH1-S (H) neck pu
- ACH2-S (H) bridge pu
- Hardware color : Chrome
- Scale : 628mm/24.75"
- depth : 43mm at tail
- Color : BKF (Black Flat)

AM/AMF

Don't be fooled by its smaller size – the AM model has all the power, presence and features of its larger cousins. It's perfect for smaller players or anyone else who wants the traditional semi-acoustic elements but not the traditional size.



AMF73 BK

- Artcore Mahogany set-in neck
- Maple top/back/sides
- Medium frets
- ART-1 bridge
- ACH1-S (H) neck pu
- ACH2-S (H) bridge pu
- Hardware color : Chrome
- Scale : 628mm/24.75"
- depth : 43mm at tail
- Colors : TF (Tobacco Flat)
BK (Black)



AMF73 TF

- Artcore Mahogany set-in neck
- Maple top/back/sides
- Medium frets
- ART-1 bridge
- ACH1-S (H) neck pu
- ACH2-S (H) bridge pu
- Hardware color : Chrome
- Scale : 628mm/24.75"
- depth : 43mm at tail
- Colors : TF (Tobacco Flat)
BK (Black)



AMF 60'S STYLE

AMF73 BK and AMF73 TF models shout a 60's look and feel, with semi-hollow, flat-top bodies and even chicken head knobs!



John Lamacchia
Candiria, A Family Plot

Parker Lauzon
Evans Blue

Antoine Lussier
Ion Dissonance

Christofer Malmström
Darkane

Lee McKinney
Born of Osiris

Patrick Meadows
Gwen Stacy

Mark Mitchell
Throwdown

Atsushi Miyamoto
Opus Dai

Kristian Niemann
Demonoid

Per Nilsson
Scar Symmetry

Photo by: Kelly Milliman/Dark Photography

Ben Orum
All Shall Perish

Jack Owen
Deicide

OX
LORDI

Matt Pantelis
Veil Of Maya

Pat Pattison
Straight Line Stitch

Rufus Philpot
Planet X, Down to the Bone

Joe Pitter
Evans Blue

Matthew Pugh
The Eyes Of A Traitor

Scott Root
Dirtfidd

Tim Roth
Into Eternity

Caleb Schneider
Bad Acid Trip

Jake Scott
Salt the Wound

Arthur Seay
House of Broken Promises

Waldemar Sorychta
Enemy of the Sun, ReVamp

Nita Strauss
Kill Slowly, As Blood Runs Black

Vince Stropki
Salt the Wound

Seth Thacker
Straight Line Stitch

Gunnar H. Thomsen
Tyr

Elias Viljanen
Sonata Arctica

Paul Waudby
The Eyes Of A Traitor

Jason White
Straight Line Stitch

Mick Whitney
36 Crazyfists

Steve Whitworth
The Eyes Of A Traitor

Jussi Wickström
Turisas

Mark Young
(hed) planet earth

Electric Basses

For 2010, we've expanded the SR line in many exciting ways, including the introduction of the formidable SRT model. With its modern aesthetic, neck-thru construction and US made EMG® pickups, the SRT is the perfect choice for any style. Also joining the line this year is the SRA, designed for players who need a thick yet articulate low end. Great for heavy styles, its EMG® pickups and arched top/flat back design accentuate the bass frequencies in all the right places.



SR *Prestige*

CRAFTED BY JAPANESE FINEST LUTHIERS

The SR Prestige is the pinnacle of playing comfort, smart design and Japanese craftsmanship. All SR Prestige models are “Made in Japan” by the finest Ibanez craftsmen and from top-of-the-line components. They feature the Mono-Rail bridge design, with complete string-to-string isolation so that each string vibrates without interference from other strings, the newly developed Power Curve III EQ for vitalizing the low-end and midrange tones, and the same classic slim neck that has become an industry standard over the past 20 years.



Power Curve III EQ on SR Prestige

The Power Curve III 3-band EQ was developed specifically for our new SR Prestige line. The Mid Q control makes adjustment of the core of your bass – the mids – extremely simple, and the +/-12dB EQ variable range enables a more natural sounding bass tone. Equipped with an EQ On/Off switch that outputs directly from the Bartolini® pickup.

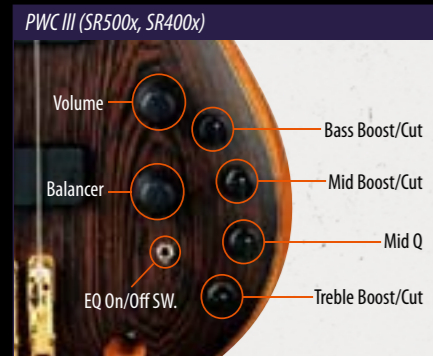

SR5000E OL

- 5pc Atlas-4 HP Wenge /Bubinga neck *Prestige* w/KTS™ TITANIUM Reinforcement
- BLACK TUSQ XL® NUT
- Wenge/Mahogany/Wenge body
- Medium frets
- MR-4 bridge (19mm string spacing)
- USA Bartolini® Custom neck pu
- USA Bartolini® Custom bridge pu
- PWC III 3-band eq
- Elixir® strings
- Hardware color : Gold
- Scale : 864mm/34"
- Color : OL (Oil)

SR5006E OL

- 5pc Atlas-6 HP Wenge /Bubinga neck *Prestige* w/KTS™ TITANIUM Reinforcement
- BLACK TUSQ XL® NUT
- Wenge/Mahogany/Wenge body
- Medium frets
- MR-4 bridge (16.5mm string spacing)
- USA Bartolini® Custom neck pu
- USA Bartolini® Custom bridge pu
- PWC III 3-band eq
- Elixir® strings
- Hardware color : Gold
- Scale : 864mm/34"
- Color : OL (Oil)



SR5005E OL

- 5pc Atlas-5 HP Wenge /Bubinga neck *Prestige* w/KTS™ TITANIUM Reinforcement
- BLACK TUSQ XL® NUT
- Wenge/Mahogany/Wenge body
- Medium frets
- MR-4 bridge (16.5mm string spacing)
- USA Bartolini® Custom neck pu
- USA Bartolini® Custom bridge pu
- PWC III 3-band eq
- Elixir® strings
- Hardware color : Gold
- Scale : 864mm/34"
- Color : OL (Oil)

Gerald Veasley

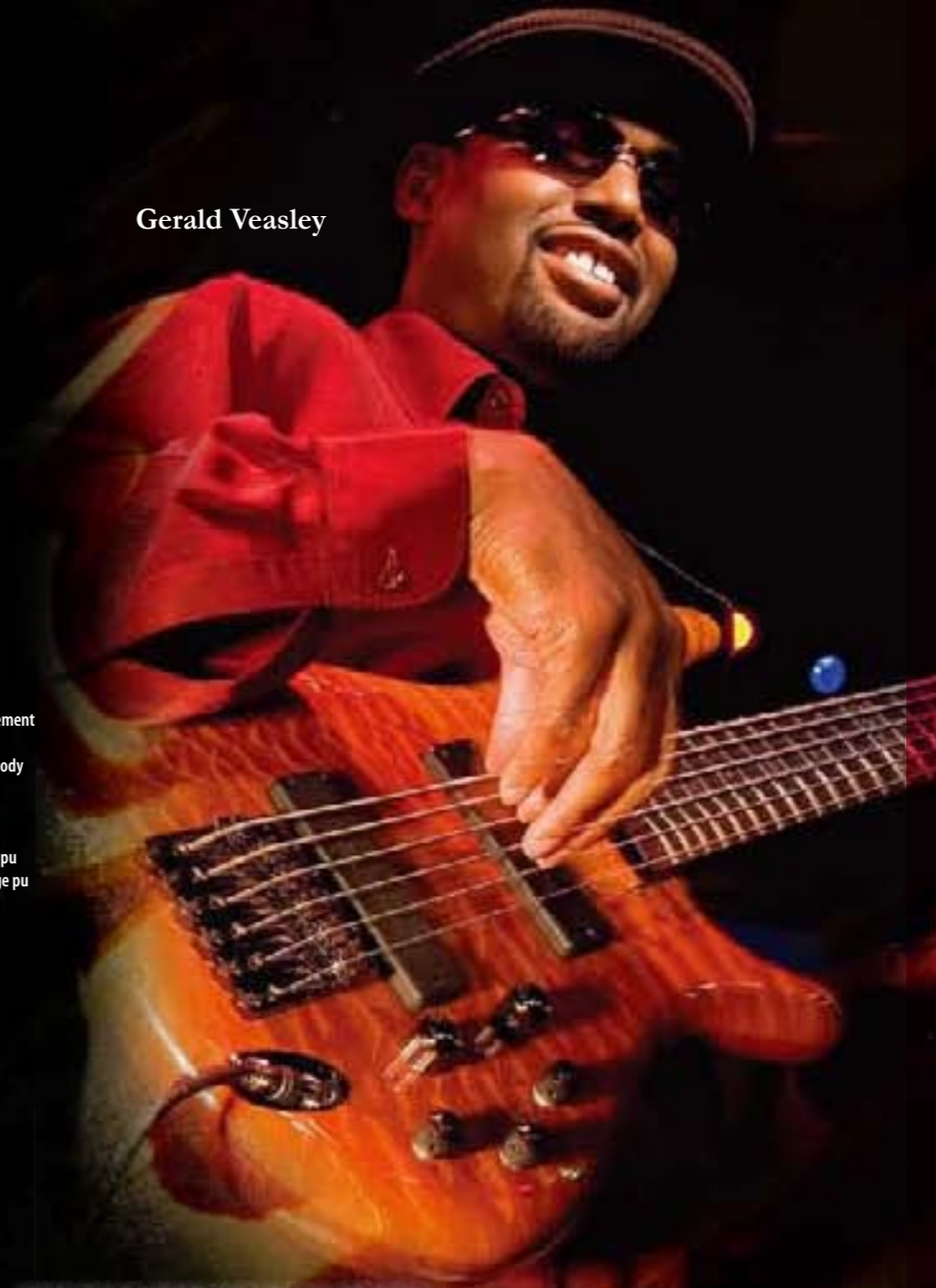

MR4 Mono-Rail Bridge

The Mono-Rail Bridge is the ultimate in string isolation for bass. Each saddle is independently and securely locked down to the body for maximum vibration transfer and no interference. One screw controls the height of each saddle for easy adjustment.

Bartolini® US made Pickups

The US made pickups are hand made at our factory in California exclusively for Ibanez. Ibanez was the first to ask for much deeper tone from the neck pickup while retaining a bright tone for the bridge, unlike traditional designs that used approximately equal pickup tone. The pickups are dual coil designs in several soapbar shapes, some rounded top and some flat top. In all cases, the Neck pickup tone is very deep and the Bridge pickup tone is bright. This allows the widest tonal sweep from the Blend control. Enjoy the wide tonal range! —Bill Bartolini—



SR *Prestige*

CRAFTED BY JAPANESE FINEST LUTHIERS



SR4005E TKF

- 5pc Atlas-5 HP Wenge /Bubinga neck *Prestige*
- w/KTS™ TITANIUM Reinforcement
- BLACK TUSQ XL™ NUT
- Mahogany body
- Medium frets
- MR-4 bridge (16.5mm string spacing)
- USA Bartolini® Custom neck pu
- USA Bartolini® Custom bridge pu
- PWC III 3-band eq
- Elixir® strings
- Hardware color : Cosmo Black
- Scale : 864mm/34"
- Colors : SDR (Stained Red) TKF (Transparent Black Flat)



SR4005E SDR

- 5pc Atlas-5 HP Wenge /Bubinga neck *Prestige*
- w/KTS™ TITANIUM Reinforcement
- BLACK TUSQ XL™ NUT
- Mahogany body
- Medium frets
- MR-4 bridge (16.5mm string spacing)
- USA Bartolini® Custom neck pu
- USA Bartolini® Custom bridge pu
- PWC III 3-band eq
- Elixir® strings
- Hardware color : Cosmo Black
- Scale : 864mm/34"
- Colors : SDR (Stained Red) TKF (Transparent Black Flat)

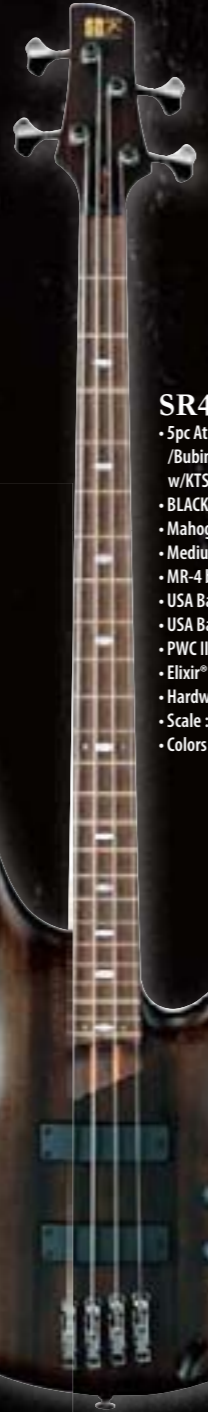

SR4000E TKF

- 5pc Atlas-4 HP Wenge /Bubinga neck *Prestige*
- w/KTS™ TITANIUM Reinforcement
- BLACK TUSQ XL™ NUT
- Mahogany body
- Medium frets
- MR-4 bridge (19mm string spacing)
- USA Bartolini® Custom neck pu
- USA Bartolini® Custom bridge pu
- PWC III 3-band eq
- Elixir® strings
- Hardware color : Cosmo Black
- Scale : 864mm/34"
- Colors : SDR (Stained Red) TKF (Transparent Black Flat)



SR4000E SDR

- 5pc Atlas-4 HP Wenge /Bubinga neck *Prestige*
- w/KTS™ TITANIUM Reinforcement
- BLACK TUSQ XL™ NUT
- Mahogany body
- Medium frets
- MR-4 bridge (19mm string spacing)
- USA Bartolini® Custom neck pu
- USA Bartolini® Custom bridge pu
- PWC III 3-band eq
- Elixir® strings
- Hardware color : Cosmo Black
- Scale : 864mm/34"
- Colors : SDR (Stained Red) TKF (Transparent Black Flat)

PWC III (SR500x, SR400x)

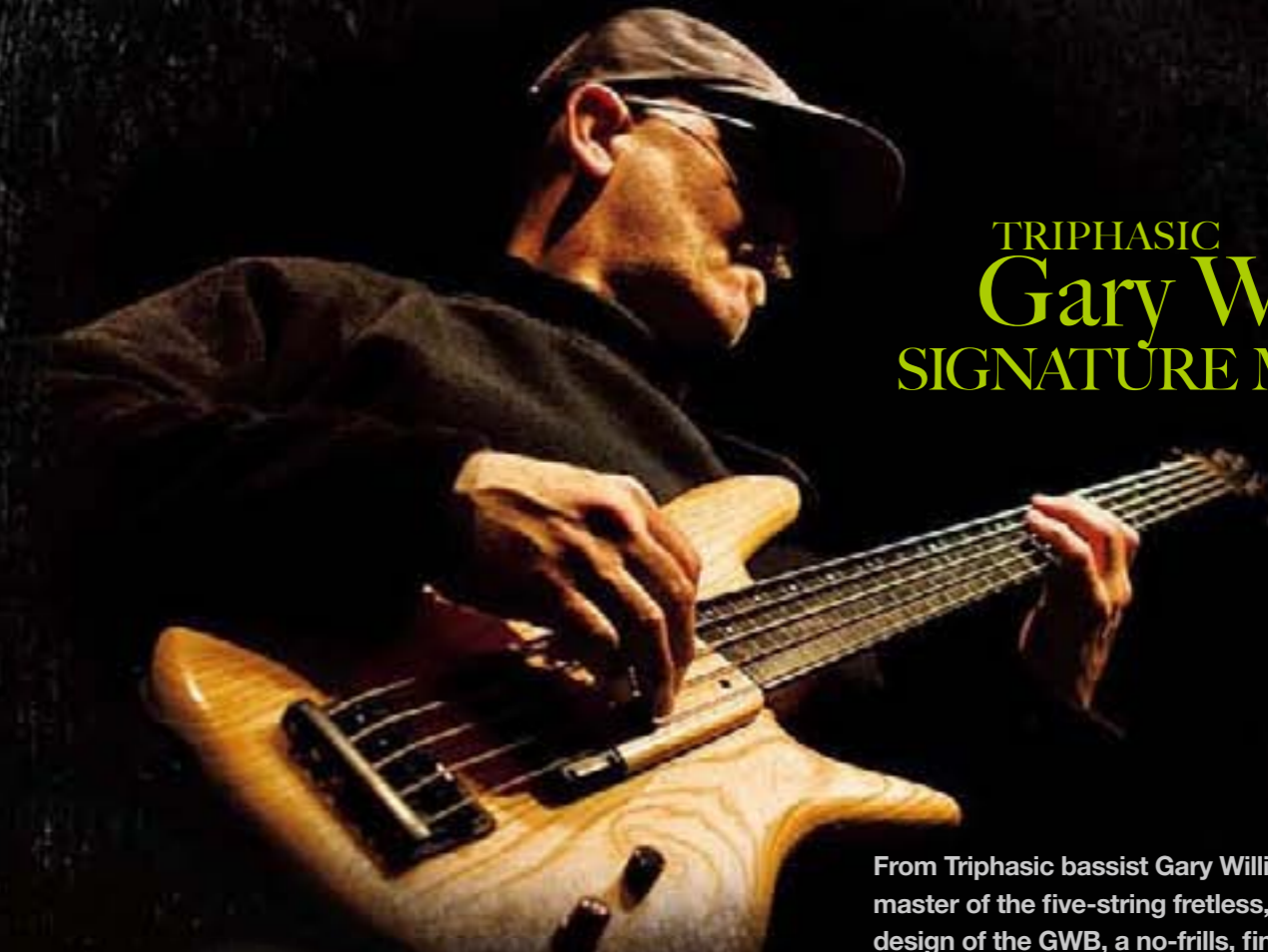
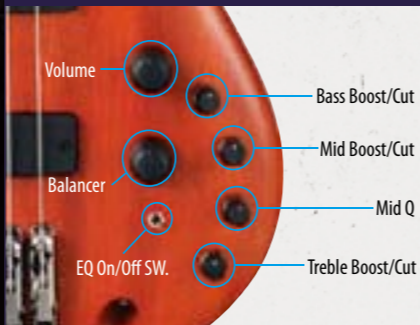

TRIPHASIC Gary Willis SIGNATURE MODELS

From Triphasic bassist Gary Willis, the acclaimed master of the five-string fretless, comes the design of the GWB, a no-frills, finely tuned instrument made for the player who desires total dynamic and tonal control.



GWB1005 NTF

- 3pc GWB1005 Maple neck *Prestige*
- Swamp Ash body
- Fretless
- STD-5 bridge (16.5mm string spacing)
- Bartolini® GWB pu
- Bartolini® NTBT 2-band eq
- D'Addario® Strings
- Hardware color : Black
- Scale : 864mm/34"
- Color : NTF (Natural Flat)

Bartolini® NTBT (GWB1005)

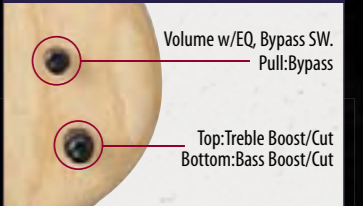

GWB35 BKF

- 3pc GWB35 Maple neck
- Basswood body
- Fretless
- B105 bridge (16.5mm string spacing)
- SFR-GWB custom wound pu
- EQB-GWII 2-band eq
- D'Addario® Strings
- Hardware color : Black
- Scale : 864mm/34"
- Color : BKF (Black Flat)

EQB-GWII (GWB35)

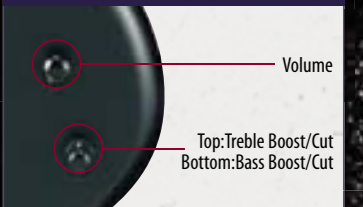



Marco Coti Zelati
Lacuna Coil



SRT

Neck-thru construction for longer sustain and US-made EMG® pickups push these animals into the realm of modern, hi-tech sound. The EMG® 40DC pickups reproduce just about anything from the cleanest highs right down to the dirtiest growling lows. Add perfect 3D-contoured ergonomics, arched top and scooped back body and you have “The Modern Bass” – ultimate gear for today’s bass race.



SRT Neck-Thru

SRT's neck-thru construction supplies longer sustain and brighter sound than traditional bolt-on necks.



SRT/EMG® Pickups

The EMG DC pickups on the SRT models offer plenty of output with balanced tonality.

SRT800DX AM

- 5pc SR4 Maple/Bubinga neck-thru
- Figured Maple/Mahogany wing body
- Medium frets
- Accu-Cast B20 bridge (19mm string spacing)
- EMG® 40DC neck pu
- EMG® 40DC bridge pu
- Vari-Mid III 3-band eq
- Elixir® strings
- Hardware color : Cosmo Black
- Scale : 864mm/34"
- Colors : AM (Amber)
- TG (Transparent Gray)

SRT805DX CN

- 5pc SR5 Maple/Bubinga neck-thru
- Figured Maple/Mahogany wing body
- Medium frets
- Accu-Cast B25 bridge (16.5mm string spacing)
- EMG® 40DC neck pu
- EMG® 40DC bridge pu
- Vari-Mid III 3-band eq
- Elixir® strings
- Hardware color : Cosmo Black
- Scale : 864mm/34"
- Color : CN (Charcoal Brown)



SRT800DX TG

- 5pc SR4 Maple/Bubinga neck-thru
- Figured Maple/Mahogany wing body
- Medium frets
- Accu-Cast B20 bridge (19mm string spacing)
- EMG® 40DC neck pu
- EMG® 40DC bridge pu
- Vari-Mid III 3-band eq
- Elixir® strings
- Hardware color : Cosmo Black
- Scale : 864mm/34"
- Colors : AM (Amber)
- TG (Transparent Gray)

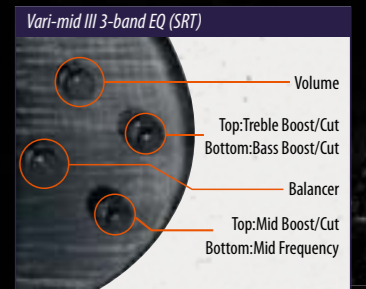

Matt Snell
Five Finger Death Punch

SRA

Introducing the SRA, our newest, affordable addition to the SR line. We forged the "Slim & Fast" of the SR with the "Heavy Bottom" of the SRX and got a new monster. The EMG® HZ pickups are onboard, for smoother attack and a flatter high end. From classic rock to heavy metal, these pickups perform. The 500 series features beautiful quilted maple tops, with EQB-3C 3-band eq. SRAs are the perfect answer for players who want heavy sound without the heavy price.



SRA500 AM

- 3pc SRA4 Maple neck
- Quilted Maple top/Mahogany body
- Medium frets
- Accu-Cast B20 bridge (19mm string spacing)
- EMG® 35HZ neck pu
- EMG® 35HZ bridge pu
- EQB-III C 3-band eq
- Elixir® strings
- Hardware color : Cosmo Black
- Scale : 864mm/34"
- Colors : AM (Amber)
- TK (Transparent Black)



SRA500 TK

- 3pc SRA4 Maple neck
- Quilted Maple top/Mahogany body
- Medium frets
- Accu-Cast B20 bridge (19mm string spacing)
- EMG® 35HZ neck pu
- EMG® 35HZ bridge pu
- EQB-III C 3-band eq
- Elixir® strings
- Hardware color : Cosmo Black
- Scale : 864mm/34"
- Colors : AM (Amber)
- TK (Transparent Black)



SRA505 BB

- 3pc SRA5 Maple neck
- Quilted Maple top/Mahogany body
- Medium frets
- Accu-Cast B25 bridge (16.5mm string spacing)
- EMG® 40HZ neck pu
- EMG® 40HZ bridge pu
- EQB-III C 3-band eq
- Elixir® strings
- Hardware color : Cosmo Black
- Scale : 864mm/34"
- Color : BB (Blackberry)



Arched Top

SRA basses feature contoured arched tops with flat-back bodies.



SRA/EMG® Pickups

The EMG® HZ pickups on the SRA models offer plenty of output with balanced tonality.

EQB-III C 3-Band EQ (SRA50x)

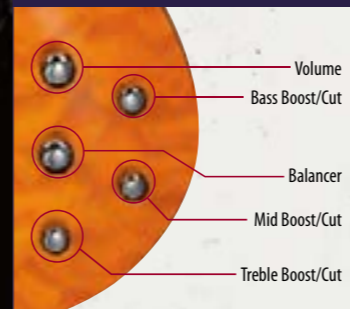

PHAT II EQ (SRA30x)

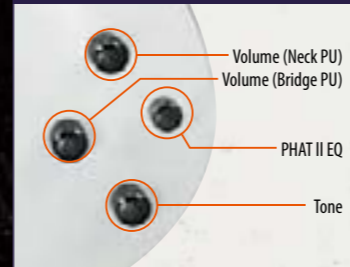

Dustin Davidson
August Burns Red

Photo by Cory Morton



SRA300 IPT

- 3pc SRA4 Maple neck
- Mahogany Body
- Medium frets
- B10 bridge (19mm string spacing)
- EMG® 35HZ neck pu
- EMG® 35HZ bridge pu
- PHAT II eq
- Elixir® strings
- Hardware color : Black
- Scale : 864mm/34"
- Colors : IPT (Iron Pewter)
- PW (Pearl White)

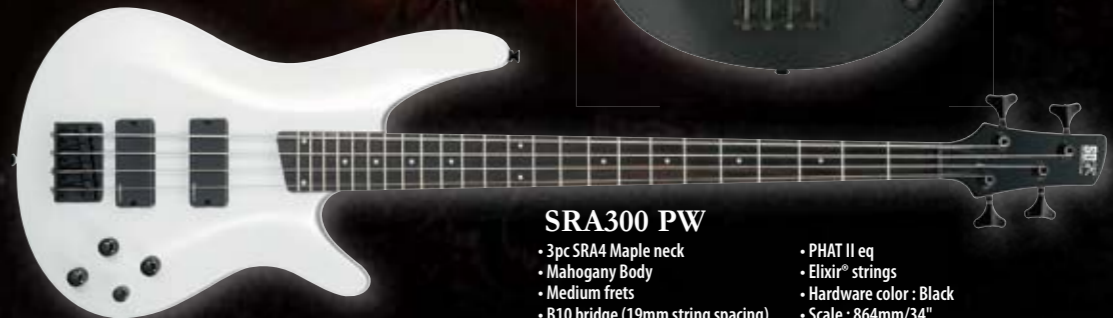

SRA300 PW

- 3pc SRA4 Maple neck
- Mahogany Body
- Medium frets
- B10 bridge (19mm string spacing)
- EMG® 35HZ neck pu
- EMG® 35HZ bridge pu
- PHAT II eq
- Elixir® strings
- Hardware color : Black
- Scale : 864mm/34"
- Colors : IPT (Iron Pewter)
- PW (Pearl White)



SRA305 IPT

- 3pc SRA5 Maple neck
- Mahogany Body
- Medium frets
- B15 bridge (16.5mm string spacing)
- EMG® 40HZ neck pu
- EMG® 40HZ bridge pu
- PHAT II eq
- Elixir® strings
- Hardware color : Black
- Scale : 864mm/34"
- Color : IPT (Iron Pewter)



KORN Fieldy SIGNATURE MODEL

A lightweight bass but some seriously heavy tone. With active pickups and the 3-band eq, any sound is possible. Korn's sound. Your sound.



K5 TKF

- 5pc K5 Maple/Bubinga neck
- Mahogany body
- Medium frets
- Die-Cast EB-7 bridge (16.5mm string spacing)
- ADXSN neck pu
- ADXSB bridge pu
- Vari-Mid III 3-band eq
- Elixir® strings
- Hardware color : Gold
- Scale : 864mm/34"
- Color : TKF (Transparent Black Flat)

Vari-Mid III (K5)

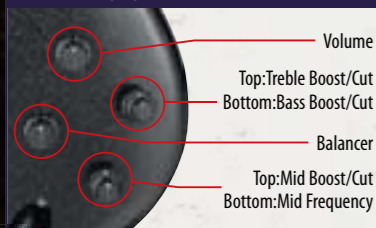

IN FLAMES Peter Iwers SIGNATURE MODEL



Iwers' bass playing in the band In Flames is as aggressive and ruthless as you can get, and this rock bass is built to take anything that comes its way. Just one look at its 5pc Maple/Bubinga neck, Maple body and dramatic inlay is all it takes to realize that this bass is a true battle axe.

PIB1 BK

- 5pc PIB Maple/Bubinga neck-thru
- Maple wing body
- Medium frets
- MR-4 bridge (16.5mm string spacing)
- USA Bartolini® Custom neck pu
- USA Bartolini® Custom bridge pu
- 1-volume control w/PIB Active circuit
- D'Addario® Strings
- Hardware color : Gold
- Scale : 864mm/34"
- Factory Tuning :
1D#, 2A#, 3F, 4C, 5A#
- String Gauge :
.045/ .065/ .085/ .105/ .120
- Color : BK (Black)



Peter Iwers' Signature PIB1BK features 2 Bartolini® Custom pickups.



Back view of Peter Iwers' PIB1BK which features a 5pc maple/bubinga PIB4 thru-neck for increased sustain.



SR750 BSF

- 5pc SR4 Jatoba/Bubinga neck
- Walnut/Mahogany wing body w/Maple center block
- Medium frets
- Accu-Cast B20 bridge (19mm string spacing)
- Bartolini® MK1 neck pu
- Bartolini® MK1 bridge pu
- EQB-III 3-band eq
- Elixir® strings
- Hardware color : Gold
- Scale : 864mm/34"
- Color : BSF (Brown Sunburst Flat)

SR755 BSF

- 5pc SR5 Jatoba/Bubinga neck
- Walnut/Mahogany wing body w/Maple center block
- Medium frets
- Accu-Cast B25 bridge (16.5mm string spacing)
- Bartolini® MK1 neck pu
- Bartolini® MK1 bridge pu
- EQB-III 3-band eq
- Elixir® strings
- Hardware color : Gold
- Scale : 864mm/34"
- Color : BSF (Brown Sunburst Flat)

SR700 AM

- 5pc SR4 Jatoba/Bubinga neck
- Figured Maple /Mahogany wing body w/Maple center block
- Medium frets
- Accu-Cast B20 bridge (19mm string spacing)
- Bartolini® MK1 neck pu
- Bartolini® MK1 bridge pu
- EQB-III 3-band eq
- Elixir® strings
- Hardware color : Cosmo Black
- Scale : 864mm/34"
- Colors : AM (Amber) CN (Charcoal Brown)

SR700 CN

- 5pc SR4 Jatoba/Bubinga neck
- Figured Maple /Mahogany wing body w/Maple center block
- Medium frets
- Accu-Cast B20 bridge (19mm string spacing)
- Bartolini® MK1 neck pu
- Bartolini® MK1 bridge pu
- EQB-III 3-band eq
- Elixir® strings
- Hardware color : Cosmo Black
- Scale : 864mm/34"
- Colors : AM (Amber) CN (Charcoal Brown)



SR705 NT

- 5pc SR5 Jatoba/Bubinga neck
- Figured Maple /Mahogany wing body w/Maple center block
- Medium frets
- Accu-Cast B25 bridge (16.5mm string spacing)
- Bartolini® MK1 neck pu
- Bartolini® MK1 bridge pu
- EQB-III 3-band eq
- Elixir® strings
- Hardware color : Cosmo Black
- Scale : 864mm/34"
- Colors : NT (Natural) TK (Transparent Black)

SR705 TK

- 5pc SR5 Jatoba/Bubinga neck
- Figured Maple /Mahogany wing body w/Maple center block
- Medium frets
- Accu-Cast B25 bridge (16.5mm string spacing)
- Bartolini® MK1 neck pu
- Bartolini® MK1 bridge pu
- EQB-III 3-band eq
- Elixir® strings
- Hardware color : Cosmo Black
- Scale : 864mm/34"
- Colors : NT (Natural) TK (Transparent Black)



Stephane Barbe
Kataklysm

SR

Since 1987, musicians all over the world have come to know the playing comfort and unique sound of the SR bass. This year's lineup includes a wide array of options sure to fit just about any style of music. With 3-band EQ and its newly developed Mid-Frequency Select switch, or the Style Sweeper 3-band EQ controls, the SR basses can produce any sound you require.



Jatoba/Bubinga Slim Neck

Coupling Jatoba with Bubinga has made the neck strong and stable despite its thinness.

EQB-III EQ

In addition to 3-band EQ, the SR is now equipped with a mid-frequency select switch, enabling you to instantly select 250Hz and 600Hz – the heart of the mid zone – for a more dynamic and ideal tone.



EQB-III S (SR75x, SR70x, SR60x, SR50x)

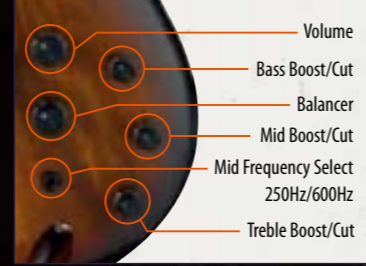

SR706 TK

- 5pc SR6 Jatoba/Bubinga neck
- Figured Maple/Mahogany wing body w/Maple center block
- Medium frets
- B106 bridge (16.5mm string spacing)
- Bartolini® MK1 neck pu
- Bartolini® MK1 bridge pu
- EQB-III 3-band eq
- Elixir® strings
- Hardware color : Cosmo Black
- Scale : 864mm/34"
- Colors : TK (Transparent Black)



Ryan Wombacher
Bleeding Through

SR

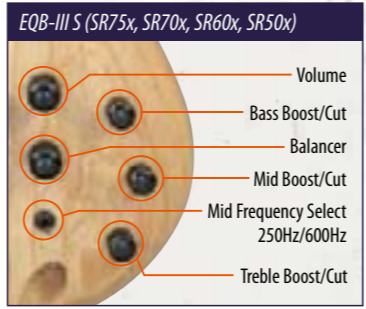

SR600 NTF

- 5pc SR4 Jatoba/Bubinga neck
- Ash body
- Medium frets
- Accu-Cast B20 bridge (19mm string spacing)
- Bartolini® MK1 neck pu
- Bartolini® MK1 bridge pu
- EQB-IIIS 3-band eq
- Elixir® strings
- Hardware color : Black Matt
- Scale : 864mm/34"
- Colors: NTF (Natural Flat) WNF (Walnut Flat)

SR600 WNF

- 5pc SR4 Jatoba/Bubinga neck
- Ash body
- Medium frets
- Accu-Cast B20 bridge (19mm string spacing)
- Bartolini® MK1 neck pu
- Bartolini® MK1 bridge pu
- EQB-IIIS 3-band eq
- Elixir® strings
- Hardware color : Black Matt
- Scale : 864mm/34"
- Colors: NTF (Natural Flat) WNF (Walnut Flat)

SR605 NTF

- 5pc SR5 Jatoba/Bubinga neck
- Ash body
- Medium frets
- Accu-Cast B25 bridge (16.5mm string spacing)
- Bartolini® MK1 neck pu
- Bartolini® MK1 bridge pu
- EQB-IIIS 3-band eq
- Elixir® strings
- Hardware color : Black Matt
- Scale : 864mm/34"
- Color : NTF (Natural Flat)



SR535 PW

- 5pc SR5 Jatoba/Bubinga neck
- Mahogany body
- Medium frets
- Accu-Cast B25 bridge (16.5mm string spacing)
- Bartolini® MK1 neck pu
- Bartolini® MK1 bridge pu
- EQB-IIIS 3-band eq
- Elixir® strings
- Hardware color : Gold
- Scale : 864mm/34"
- Color : PW (Pearl White)

SR530 PW

- 5pc SR4 Jatoba/Bubinga neck
- Mahogany body
- Medium frets
- Accu-Cast B20 bridge (19mm string spacing)
- Bartolini® MK1 neck pu
- Bartolini® MK1 bridge pu
- EQB-IIIS 3-band eq
- Elixir® strings
- Hardware color : Gold
- Scale : 864mm/34"
- Color : PW (Pearl White)



SR530's feature thinner 5-piece maple/rosewood painted necks.

SR500 BM

- 5pc SR4 Jatoba/Bubinga neck
- Mahogany body
- Medium frets
- Accu-Cast B20 bridge (19mm string spacing)
- Bartolini® MK1 neck pu
- Bartolini® MK1 bridge pu
- EQB-IIIS 3-band eq
- Elixir® strings
- Hardware color : Cosmo Black
- Scale : 864mm/34"
- Color : BM (Brown Mahogany)

SR505 BM

- 5pc SR5 Jatoba/Bubinga neck
- Mahogany body
- Medium frets
- Accu-Cast B25 bridge (16.5mm string spacing)
- Bartolini® MK1 neck pu
- Bartolini® MK1 bridge pu
- EQB-IIIS 3-band eq
- Elixir® strings
- Hardware color : Cosmo Black
- Scale : 864mm/34"
- Color : BM (Brown Mahogany)

SR506 BM

- 5pc SR6 Jatoba/Bubinga neck
- Mahogany body
- Medium frets
- B106 bridge (16.5mm string spacing)
- Bartolini® MK1 neck pu
- Bartolini® MK1 bridge pu
- EQB-IIIS 3-band eq
- Elixir® strings
- Hardware color : Cosmo Black
- Scale : 864mm/34"
- Color : BM (Brown Mahogany)



Bartolini® MK1 Pickups

The MK1 pickups are split coil designs that provides a very wide frequency range and enhanced definition for maximum accuracy. The Neck and Bridge pickups have equal response, like traditional single coils, but without the hum and noise.

Jeanne Sagan
All That Remains

SR



EXF Pickups

Versatile Ibanez EXF angled pickups have equal spacing between pickup to string for balanced output levels.



SR405QM CNB

- 5pc SR5 Maple/Rosewood neck
- Quilted Maple top/Basswood body
- Medium frets
- Accu-cast B25 bridge (16.5mm string spacing)
- EXF-5F neck pu
- EXF-5R bridge pu
- EQB-IIIB Style Sweeper 3-band eq
- Elixir® strings
- Hardware color : Cosmo Black
- Scale : 864mm/34"
- Color : CNB (Charcoal Brown Burst)



SR400QM TLB

- 5pc SR4 Maple/Rosewood neck
- Quilted Maple top/Basswood body
- Medium frets
- Accu-Cast B20 bridge (19mm string spacing)
- EXF-4F neck pu
- EXF-4R bridge pu
- EQB-IIIB Style Sweeper 3-band eq
- Elixir® strings
- Hardware color : Cosmo Black
- Scale : 864mm/34"
- Colors : CS (Cherry Sunburst) TLB (Transparent Lavender Burst)



SR400QM CS

- 5pc SR4 Maple/Rosewood neck
- Quilted Maple top/Basswood body
- Medium frets
- Accu-Cast B20 bridge (19mm string spacing)
- EXF-4F neck pu
- EXF-4R bridge pu
- EQB-IIIB Style Sweeper 3-band eq
- Elixir® strings
- Hardware color : Cosmo Black
- Scale : 864mm/34"
- Colors : CS (Cherry Sunburst) TLB (Transparent Lavender Burst)

Style Sweeper (SR40x, SR30x)

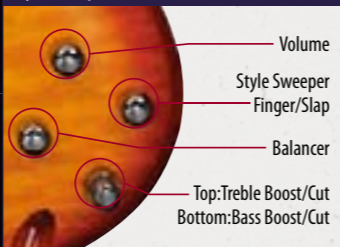

Karin Axelsson
Sonic Syndicate
Photo by Soile Siirtola



SR305M PW

- 5pc SR5 Maple/Rosewood neck
- Agathis body
- Medium frets
- B105 bridge (16.5mm string spacing)
- EXF-5F neck pu
- EXF-5R bridge pu
- EQB-IIIB Style Sweeper 3-band eq
- Hardware color : Cosmo Black
- Scale : 864mm/34"
- Color : PW (Pearl White)



SR300M PW

- 5pc SR4 Maple/Rosewood neck
- Agathis body
- Medium frets
- B100 bridge (19mm string spacing)
- EXF-4F neck pu
- EXF-4R bridge pu
- EQB-IIIB Style Sweeper 3-band eq
- Hardware color : Cosmo Black
- Scale : 864mm/34"
- Colors : CA (Candy Apple) PW (Pearl White)



SR300M CA

- 5pc SR4 Maple/Rosewood neck
- Agathis body
- Medium frets
- B100 bridge (19mm string spacing)
- EXF-4F neck pu
- EXF-4R bridge pu
- EQB-IIIB Style Sweeper 3-band eq
- Hardware color : Cosmo Black
- Scale : 864mm/34"
- Colors : CA (Candy Apple) PW (Pearl White)



SR300 PWF

- Fretless
- 5pc SR4 Maple/Rosewood neck
- Agathis body
- Medium frets
- B100 bridge (19mm string spacing)
- EXF-4F neck pu
- EXF-4R bridge pu
- EQB-IIIB Style Sweeper 3-band eq
- Hardware color : Cosmo Black
- Scale : 864mm/34"
- Color : PW (Pearl White)



The fretless SR300PWF features a 5-piece maple/rosewood SR4 neck with an Ebonol fretboard.

SR

SR300 IPT

- 5pc SR4 Maple/Rosewood neck
- Agathis body
- Medium frets
- B100 bridge (19mm string spacing)
- EXF-4F neck pu
- EXF-4R bridge pu
- EQB-IIIB Style Sweeper 3-band eq
- Hardware color : Cosmo Black
- Scale : 864mm/34"
- Colors : BSP (Blue Sparkle)
IPT (Iron Pewter)
GSP (Green Sparkle)
ROM (Roadster Orange Metallic)
RSP (Red Sparkle)
SVP (Silver Sparkle)

SR300 BSP

- 5pc SR4 Maple/Rosewood neck
- Agathis body
- Medium frets
- B100 bridge (19mm string spacing)
- EXF-4F neck pu
- EXF-4R bridge pu
- EQB-IIIB Style Sweeper 3-band eq
- Hardware color : Cosmo Black
- Scale : 864mm/34"
- Colors : BSP (Blue Sparkle)
IPT (Iron Pewter)
GSP (Green Sparkle)
ROM (Roadster Orange Metallic)
RSP (Red Sparkle)
SVP (Silver Sparkle)

SR300 ROM

- 5pc SR4 Maple/Rosewood neck
- Agathis body
- Medium frets
- B100 bridge (19mm string spacing)
- EXF-4F neck pu
- EXF-4R bridge pu
- EQB-IIIB Style Sweeper 3-band eq
- Hardware color : Cosmo Black
- Scale : 864mm/34"
- Colors : BSP (Blue Sparkle)
IPT (Iron Pewter)
GSP (Green Sparkle)
ROM (Roadster Orange Metallic)
RSP (Red Sparkle)
SVP (Silver Sparkle)

SR300 GSP

- 5pc SR4 Maple/Rosewood neck
- Agathis body
- Medium frets
- B100 bridge (19mm string spacing)
- EXF-4F neck pu
- EXF-4R bridge pu
- EQB-IIIB Style Sweeper 3-band eq
- Hardware color : Cosmo Black
- Scale : 864mm/34"
- Colors : BSP (Blue Sparkle)
IPT (Iron Pewter)
GSP (Green Sparkle)
ROM (Roadster Orange Metallic)
RSP (Red Sparkle)
SVP (Silver Sparkle)

SR300 RSP

- 5pc SR4 Maple/Rosewood neck
- Agathis body
- Medium frets
- B100 bridge (19mm string spacing)
- EXF-4F neck pu
- EXF-4R bridge pu
- EQB-IIIB Style Sweeper 3-band eq
- Hardware color : Cosmo Black
- Scale : 864mm/34"
- Colors : BSP (Blue Sparkle)
IPT (Iron Pewter)
GSP (Green Sparkle)
ROM (Roadster Orange Metallic)
RSP (Red Sparkle)
SVP (Silver Sparkle)

Glen Benton
Decide, Vital Remains

SR300 IPTL

- Left-Handed
- 5pc SR4 Maple/Rosewood neck
- Agathis body
- Medium frets
- B100 bridge (19mm string spacing)
- EXF-4F neck pu
- EXF-4R bridge pu
- EQB-IIIB Style Sweeper 3-band eq
- Hardware color : Cosmo Black
- Scale : 864mm/34"
- Colors : IPT (Iron Pewter)

SR300 SVP

- 5pc SR4 Maple/Rosewood neck
- Agathis body
- Medium frets
- B100 bridge (19mm string spacing)
- EXF-4F neck pu
- EXF-4R bridge pu
- EQB-IIIB Style Sweeper 3-band eq
- Hardware color : Cosmo Black
- Scale : 864mm/34"
- Colors : BSP (Blue Sparkle)
IPT (Iron Pewter)
GSP (Green Sparkle)
ROM (Roadster Orange Metallic)
RSP (Red Sparkle)
SVP (Silver Sparkle)

EXF Pickups

Versatile Ibanez EXF angled pickups have equal spacing between pickup to string for balanced output levels.



Style Sweeper (SR30x)

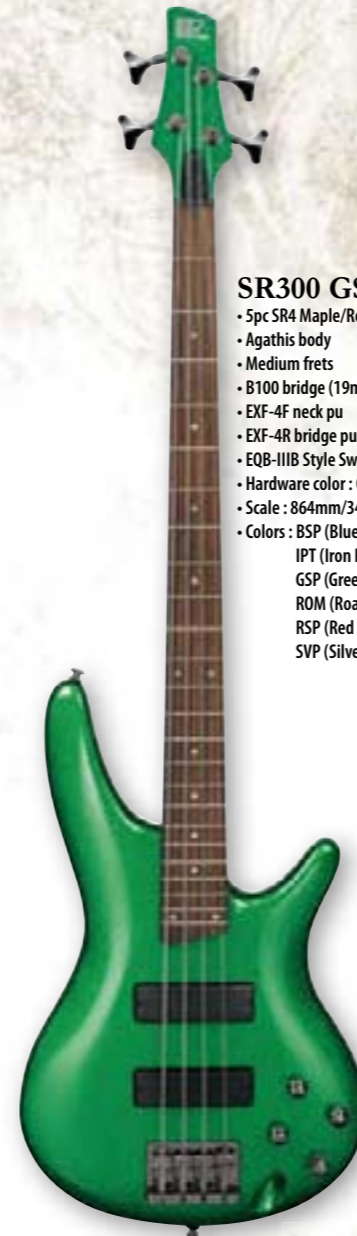
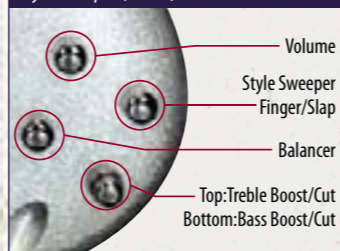

SR300's sleek and comfortable 5pc maple and rosewood neck.



SR305 IPT

- 5pc SR5 Maple/Rosewood neck
- Agathis body
- Medium frets
- B105 bridge (16.5mm string spacing)
- EXF-5F neck pu
- EXF-5R bridge pu
- EQB-IIIB Style Sweeper 3-band eq
- Hardware color : Cosmo Black
- Scale : 864mm/34"
- Colors : IPT (Iron Pewter)
OSP (Orange Sparkle)



SR305 OSP

- 5pc SR5 Maple/Rosewood neck
- Agathis body
- Medium frets
- B105 bridge (16.5mm string spacing)
- EXF-5F neck pu
- EXF-5R bridge pu
- EQB-IIIB Style Sweeper 3-band eq
- Hardware color : Cosmo Black
- Scale : 864mm/34"
- Colors : IPT (Iron Pewter)
OSP (Orange Sparkle)

SRX

The SRX is the muscular big brother of the SR series. This is a bass that was designed for heavier playing styles, and it meets that demand in a no-nonsense layout. The EQB-IIDX 2-band EQ makes it easy to find various sounds, and the now-famous stock Ibanez PFR pickups, which major artists rave about, are right there to give you that extra punch.



Nelson Braxton
The Braxton Brothers,
Michael Bolton

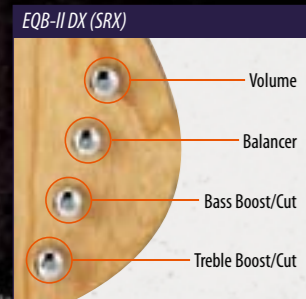

SRX350 NT

- 3pc SRX4 Maple neck
- Ash body
- Medium frets
- Accu-Cast B200 bridge (19mm string spacing)
- PFR-N4 neck pu
- PFR-B4 bridge pu
- EQB-II DX 2-band eq
- Hardware color : Chrome
- Scale : 864mm/34"
- Colors : NT (Natural)
TK(Transparent Black)



SRX350 TK

- 3pc SRX4 Maple neck
- Ash body
- Medium frets
- Accu-Cast B200 bridge (19mm string spacing)
- PFR-N4 neck pu
- PFR-B4 bridge pu
- EQB-II DX 2-band eq
- Hardware color : Chrome
- Scale : 864mm/34"
- Colors : NT (Natural)
TK(Transparent Black)



SRX355 NT

- 3pc SRX5 Maple neck
- Ash body
- Medium frets
- Accu-Cast B205 bridge (18mm string spacing)
- PFR-N5 neck pu
- PFR-B5 bridge pu
- EQB-II DX 2-band eq
- Hardware color : Chrome
- Scale : 864mm/34"
- Color : NT (Natural)



Joe Payne
Divine Heresy

Carol Kaye

KILLSWITCH ENGAGE Mike D'Antonio SIGNATURE MODEL

Sometimes straightforward brute force is the only answer. Killswitch Engage's Mike D'Antonio would agree. His signature MDB2, modeled after the SRX700, has a simplified layout of only one volume control and two PFR high-output pickups. Mike's striking laser-engraved graphic will ensure you get noticed while you're raging on this beast.

MDB2 BM

- 5pc MDB Maple/Walnut neck-thru
- Mahogany wing body
- Medium frets
- Accu-Cast B200 bridge (19mm string spacing)
- PFR-ALN4 neck pu
- PFR-ALB4 bridge pu
- 1-volume control w/MDB Active circuit
- D'Addario® strings
- Hardware color : Cosmo Black
- Scale : 864mm/34"
- Factory Tuning : 1F, 2C, 3G, 4C
- String Gauge : .055/.075/.095/.120
- Color : BM (Brown Mahogany)

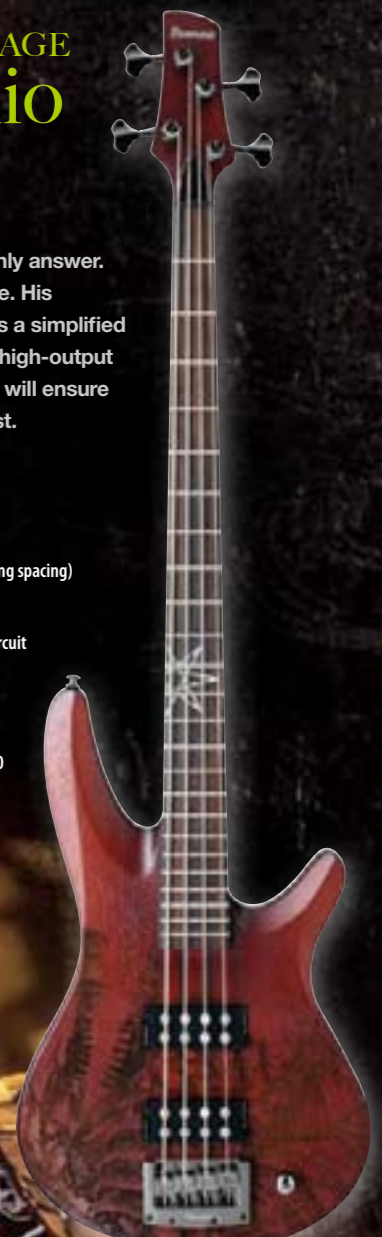

SHADOWS FALL Paul Romanko SIGNATURE MODEL

Paul Romanko wanted his streamlined signature PRB2 to be simple and powerful. Ibanez delivered : just one volume control and a massive 5pc bolt-on neck. This bass isn't for polite conversation, it's for in-your-face low-end demolition.

PRB2 BWF

- 5pc PRB Maple/Walnut neck
- Ash wing/Ash center w/Walnut stripe body
- Medium frets
- MR-4 bridge (19mm string spacing)
- PFR-ALN4 neck pu
- PFR-ALB4 bridge pu
- 1-volume control w/PRB Active circuit
- D'Addario® strings
- Hardware color : Cosmo Black
- Scale : 864mm/34"
- Factory Tuning : 1F, 2C, 3G, 4D
- String Gauge : .050/.070/.085/.105
- Color : BWF (Burgundy Wine Flat)





Mark Davis
Emmure

Lee Foral
After the Burial

Roland Guerin
Marcus Roberts Trio

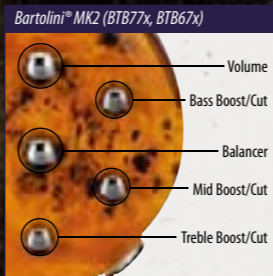

BTB

The concepts behind boutique basses are often the justification for making them extremely expensive. With the advent of the BTB however, Ibanez decided that these same concepts of well-selected body materials, 35" neck scale, and deep cutaways could be applied to an instrument that anyone could afford. All the BTBs feature neck-thru construction and deeper cutaways for enhanced playability and balance.



BTB776PB AM

- 5pc BTB6 Maple /Bubinga neck-thru
- Poplar Burl top /Mahogany wing body
- Medium frets
- MR-2 bridge (17mm string spacing)
- Bartolini® MK2 neck pu
- Bartolini® MK2 bridge pu
- Bartolini® MK2 3-band eq
- Elixir® strings
- Hardware color : Cosmo Black
- Scale : 889mm/35"
- Color : AM (Amber)

BTB775PB CN

- 5pc BTB5 Maple /Bubinga neck-thru
- Poplar Burl top /Mahogany wing body
- Medium frets
- MR-2 bridge (19mm string spacing)
- Bartolini® MK2 neck pu
- Bartolini® MK2 bridge pu
- Bartolini® MK2 3-band eq
- Elixir® strings
- Hardware color : Cosmo Black
- Scale : 889mm/35"
- Color : CN (Charcoal Brown)

BTB676 NTF

- 5pc BTB6 Maple /Bubinga neck-thru
- Walnut/Ash wing body
- Medium frets
- MR-2 bridge (17mm string spacing)
- Bartolini® MK2 neck pu
- Bartolini® MK2 bridge pu
- Bartolini® MK2 3-band eq
- Elixir® strings
- Hardware color : Cosmo Black
- Scale : 889mm/35"
- Color : NTF (Natural Flat)

BTB675 NTF

- 5pc BTB5 Maple /Bubinga neck-thru
- Walnut/Ash wing body
- Medium frets
- MR-2 bridge (19mm string spacing)
- Bartolini® MK2 neck pu
- Bartolini® MK2 bridge pu
- Bartolini® MK2 3-band eq
- Elixir® strings
- Hardware color : Cosmo Black
- Scale : 889mm/35"
- Color : NTF (Natural Flat)



Fredrik Larsson
HammerFall

Anders Iwers
Tiamat



ICB

The Iceman has long been one of the more adventurous body styles from Ibanez. In the bass world, it means a massive piece of mahogany and high-powered pickups to create tones that are absolutely earth shattering.

ICB300EX BK

- 3pc ICB4 Maple neck
- Mahogany body
- Medium frets
- B100 bridge (19mm string spacing)
- PFR-N4 neck pu (black pole piece)
- PFR-B4 bridge pu (black pole piece)
- EQB-II DX 2-band eq
- Elixir® strings
- Hardware color : Black
- Scale : 864mm/34"
- Color : BK (Black)

ICB300EX WH

- 3pc ICB4 Maple neck
- Mahogany body
- Medium frets
- B100 bridge (19mm string spacing)
- PFR-N4 neck pu (black pole piece)
- PFR-B4 bridge pu (black pole piece)
- EQB-II DX 2-band eq
- Elixir® strings
- Hardware color : Black
- Scale : 864mm/34"
- Color : BK (Black)
- Color : WH (White)

ARCH ENEMY Sharlee D'Angelo SIGNATURE MODEL

SDB1 BKF

- 5pc SDB Maple/Bubinga neck-thru
- Mahogany wing body
- Medium frets
- MR-4 bridge (19mm string spacing)
- PFR-N4 neck pu (black pole piece)
- PFR-B4 bridge pu (black pole piece)
- EQB-II DX 2-band eq
- D'Addario® Strings
- Hardware color : Cosmo Black
- Scale : 864mm/34"
- Factory Tuning : 1D#, 2A#, 3F, 4C
- String Gauge : .060/.080/.100/.120
- Color : BKF (Black Flat)

Any bass that takes the stage night after night with Arch Enemy has to take a brutal pounding without sacrificing tone. Made to Sharlee's custom specs with powerful PFR pickups and Iron Cross neck inlays, the Iceman-inspired SDB1 looks as sinister as it sounds.

EQB II DX (ICB300, SDB)

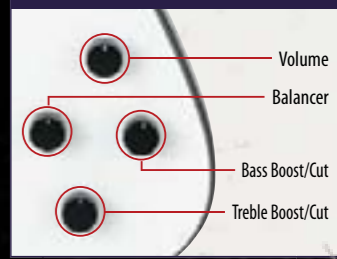

Adam Blackstone
Kanye West, Janet Jackson

Mike Murphy
Haste The Day
Photo by Bryan Minear

ATK 3 BAND EQ (ATK, PGB)

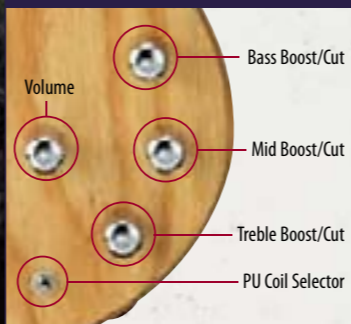

ATK

The ATK may be the most straightforward bass in the entire Ibanez line. This simple rock n' roll bass with a punk attitude combines a large ash body with a maple neck for big, tight sounds. The special ATK triple coil pickups can only be found on these basses. Coupled with the 3-band EQ, this bass can generate some serious low-end punch.

 <p>ATK300 RSP</p> <ul style="list-style-type: none"> • 3pc ATK4 Maple neck • Ash body • Jumbo frets • ATK4 bridge (19mm string spacing) • ATK Triple coil pu • ATK 3-band eq • Elixir® strings • Hardware color: Chrome • Scale: 864mm/34" • Colors: NT (Natural) • BK (Black) • RSP (Red Sparkle) 	 <p>ATK300 NT</p> <ul style="list-style-type: none"> • 3pc ATK4 Maple neck • Ash body • Jumbo frets • ATK4 bridge (19mm string spacing) • ATK Triple coil pu • ATK 3-band eq • Elixir® strings • Hardware color: Chrome • Scale: 864mm/34" • Colors: NT (Natural) • BK (Black) • RSP (Red Sparkle) 	 <p>ATK300 BK</p> <ul style="list-style-type: none"> • 3pc ATK4 Maple neck • Ash body • Jumbo frets • ATK4 bridge (19mm string spacing) • ATK Triple coil pu • ATK 3-band eq • Elixir® strings • Hardware color: Chrome • Scale: 864mm/34" • Colors: NT (Natural) • BK (Black) • RSP (Red Sparkle) 	 <p>ATK305 TFB</p> <ul style="list-style-type: none"> • 3pc ATK5 Maple neck • Ash body • Jumbo frets • ATK5 bridge (17mm string spacing) • ATK Triple coil pu • ATK 3-band eq • Elixir® strings • Hardware color: Chrome • Scale: 864mm/34" • Colors: KSP (Black Sparkle) • TFB (Tri Fade Burst) 	 <p>ATK305 KSP</p> <ul style="list-style-type: none"> • 3pc ATK5 Maple neck • Ash body • Jumbo frets • ATK5 bridge (17mm string spacing) • ATK Triple coil pu • ATK 3-band eq • Elixir® strings • Hardware color: Chrome • Scale: 864mm/34" • Colors: KSP (Black Sparkle) • TFB (Tri Fade Burst)
---	---	---	---	--



PGB1 BGW

- 3pc PGB Maple neck
- Ash body
- Jumbo frets
- ATK4 bridge (19mm string spacing)
- ATK triple coil pu
- ATK 3-band eq
- D'Addario® Strings
- Hardware color: Cosmo Black
- Scale: 864mm/34"
- Factory Tuning: 1D, 2A, 3E, 4B
- String Gauge: .050/.070/.090/.110
- Color: BGW (Burgundy Wine)



PGB1 BGWL

- Left-Handedd
- 3pc PGB Maple neck
- Ash body
- Jumbo frets
- ATK4 bridge (19mm string spacing)
- ATK triple coil pu
- ATK 3-band eq
- D'Addario® Strings
- Hardware color: Cosmo Black
- Scale: 864mm/34"
- Factory Tuning: 1D, 2A, 3E, 4B
- String Gauge: .050/.070/.090/.110
- Color: BGW (Burgundy Wine)

SLIPKNOT Paul Gray SIGNATURE MODELS

Photo by Scott Uchida

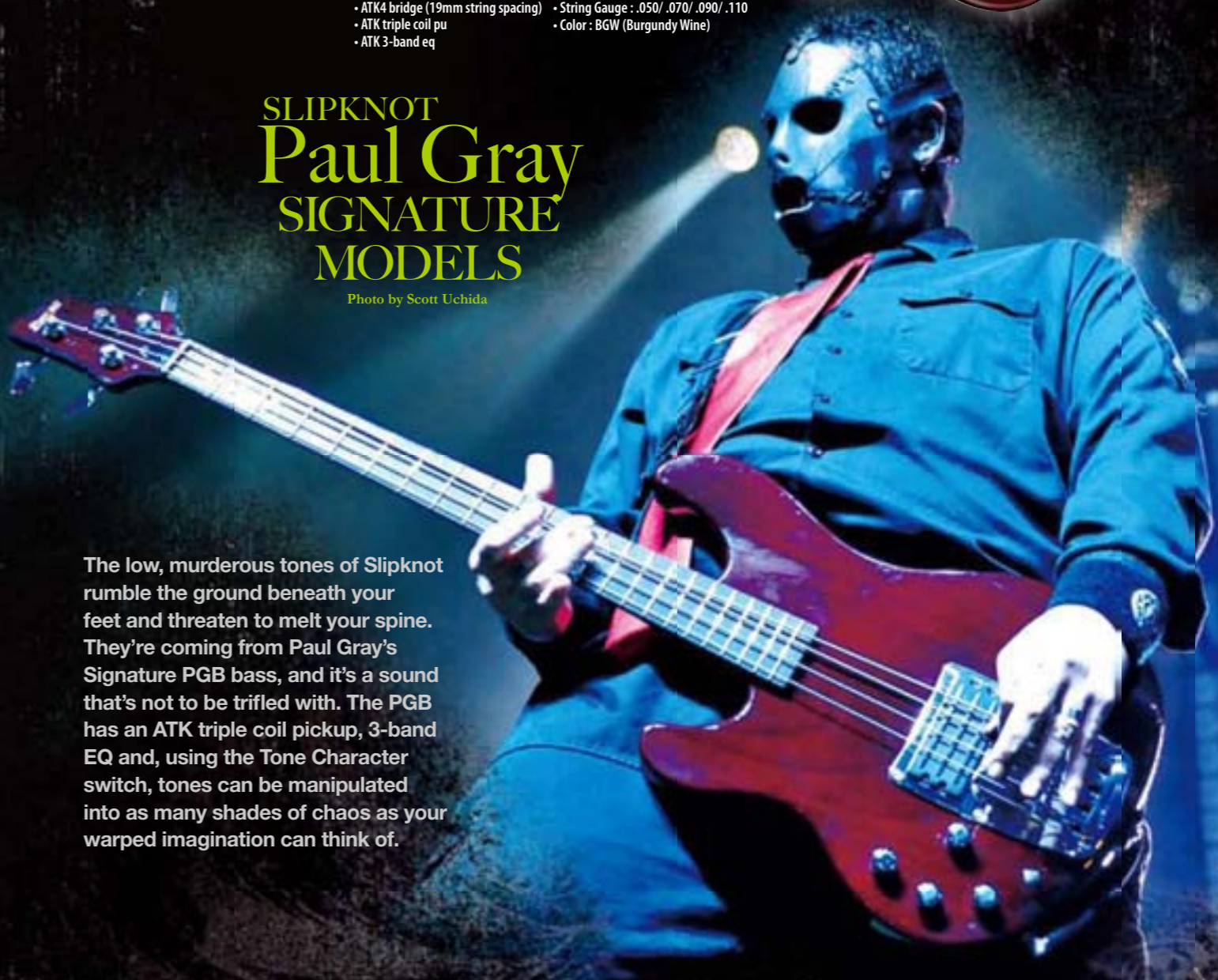

The low, murderous tones of Slipknot rumble the ground beneath your feet and threaten to melt your spine. They're coming from Paul Gray's Signature PGB bass, and it's a sound that's not to be trifled with. The PGB has an ATK triple coil pickup, 3-band EQ and, using the Tone Character switch, tones can be manipulated into as many shades of chaos as your warped imagination can think of.

ARTB

For those who prefer a bass that has a more classic feel to it, the ARTB is a 70's style rock machine. The combination of mahogany body, 30" short scale length and set neck create a warm tone that recreates the days of arena rock. The short scale neck is also comfortable for smaller hands.



ARTB100 WH

- 3pc ARTB Mahogany/Maple set-in neck
- Mahogany body
- Medium frets
- Gibraltar III bass bridge (19mm string spacing)
- Quik Change III bass tailpiece
- ACHB-2 neck pu
- ACHB-2 bridge pu
- Hardware color : Chrome
- Scale : 770mm/30.3"
- String Gauge : .050/ .070/ .085/ .105
- Colors : BK (Black) WH (White)

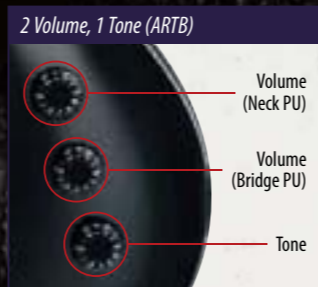

ARTB100 BK

- 3pc ARTB Mahogany/Maple set-in neck
- Mahogany body
- Medium frets
- Gibraltar III bass bridge (19mm string spacing)
- Quik Change III bass tailpiece
- ACHB-2 neck pu
- ACHB-2 bridge pu
- Hardware color : Chrome
- Scale : 770mm/30.3"
- String Gauge : .050/ .070/ .085/ .105
- Colors : BK (Black) WH (White)

Skinny Disco
Deathstars



JTKB

If you want a bass that transports you back to hot rods and 60's rock n' roll, then the JTKB is your golden ticket. Its mahogany body, high-powered pickups and solid bridge can take a beating and still produce the warm, smooth sound of a vintage bass.

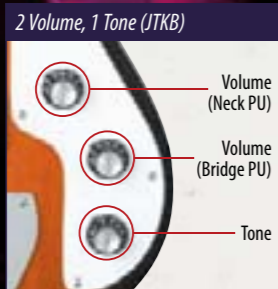

JTKB200 RD

- 3pc JTKB Maple neck
- Mahogany body
- Medium frets
- JTB10 bridge (19mm string spacing)
- ACHB-2 neck pu
- ACHB-2 bridge pu
- Elixir® strings
- Hardware color : Chrome
- Scale : 864mm/34"
- Colors : RD (Red) BS (Brown Sunburst)

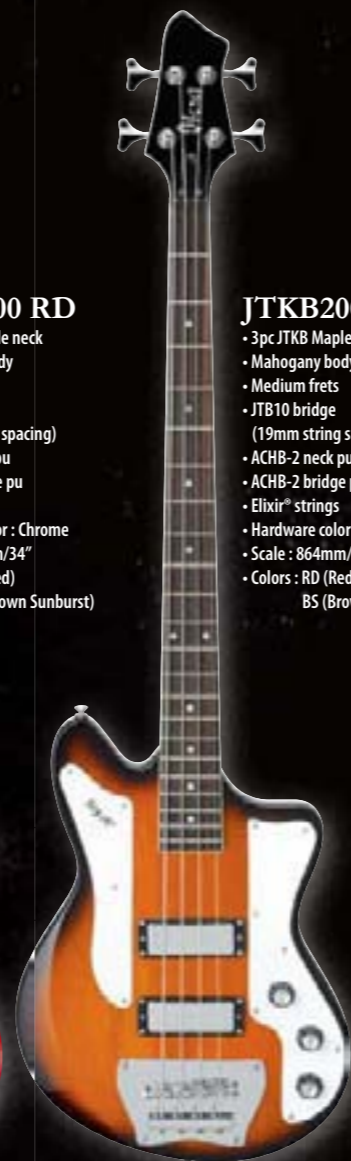

JTKB200 BS

- 3pc JTKB Maple neck
- Mahogany body
- Medium frets
- JTB10 bridge (19mm string spacing)
- ACHB-2 neck pu
- ACHB-2 bridge pu
- Elixir® strings
- Hardware color : Chrome
- Scale : 864mm/34"
- Colors : RD (Red) BS (Brown Sunburst)

ARTCORE

The Artcore Bass series was designed for players that are used to solid body basses but want the acoustic tone of a hollow body. The 30" scale neck increases playing comfort, and the acoustic body widens the palette of sounds at your disposal.

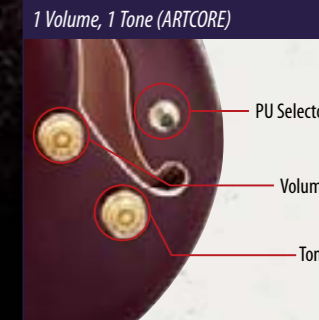

AFB200 BS

- 3pc Artcore Bass Mahogany /Maple set-in neck
- Maple top/back/sides
- Medium frets
- Wooden bridge (19mm string spacing)
- FBT40 tailpiece
- ACHB-2 neck pu
- ACHB-2 bridge pu
- Hardware color : Gold
- Scale : 770mm/30.3"
- Depth : 70mm at tail
- String Gauge : .050/.070/.085/.105
- Color : BS (Brown Sunburst)



AGB200 IV

- 3pc Artcore Bass Mahogany /Maple set-in neck
- Maple top/back/sides
- Medium frets
- Gibraltar III bass bridge (19mm string spacing)
- Quik Change III bass tailpiece
- ACHB-2 neck pu
- ACHB-2 bridge pu
- Hardware color : Gold
- Scale : 770mm/30.3"
- Depth : 43mm at tail
- String Gauge : .050/.070/.085/.105
- Color : IV (Ivory) TBR (Transparent Brown)



AGB200 TBR

- 3pc Artcore Bass Mahogany /Maple set-in neck
- Maple top/back/sides
- Medium frets
- Gibraltar III bass bridge (19mm string spacing)
- Quik Change III bass tailpiece
- ACHB-2 neck pu
- ACHB-2 bridge pu
- Hardware color : Gold
- Scale : 770mm/30.3"
- Depth : 43mm at tail
- String Gauge : .050/.070/.085/.105
- Color : IV (Ivory) TBR (Transparent Brown)

GIO

The GIO series was developed for players who want Ibanez quality in a more affordable package. Whether you're a beginner looking for your first bass guitar, or a working pro looking for a good backup for your main axe, Ibanez GSR and GSR Mikro basses deliver. And now Ibanez features the GARTB, extending the range of options for players at all levels.

GSRs offer famous Soundgear sleekness, comfort, tone, and playability, and the GSR Mikro basses are for anyone who needs a compact axe or the comfort of a smaller neck (especially young rockers). The new GARTB brings classic single-cutaway style into play, for a more distinctive look along with affordability.



GSR200FM AMB

- GSR4 Maple neck
- Flamed Maple top/Nato body
- Medium frets
- B10 bridge (19mm string spacing)
- STD-P2 neck pu
- STD-J2 bridge pu
- Phat II eq
- Hardware color : Chrome
- Scale : 864mm/34"
- Colors : AMB (Amber Burst)

- TBB (Transparent Blue Burst)
- TRB (Transparent Red Burst)

GSR200FM TBB

- GSR4 Maple neck
- Flamed Maple top/Nato body
- Medium frets
- B10 bridge (19mm string spacing)
- STD-P2 neck pu
- STD-J2 bridge pu
- Phat II eq
- Hardware color : Chrome
- Scale : 864mm/34"
- Colors : AMB (Amber Burst)

- TBB (Transparent Blue Burst)
- TRB (Transparent Red Burst)

GSR200FM TRB

- GSR4 Maple neck
- Flamed Maple top/Nato body
- Medium frets
- B10 bridge (19mm string spacing)
- STD-P2 neck pu
- STD-J2 bridge pu
- Phat II eq
- Hardware color : Chrome
- Scale : 864mm/34"
- Colors : AMB (Amber Burst)

- TBB (Transparent Blue Burst)
- TRB (Transparent Red Burst)

GSR205FM TK

- GSR5 Maple neck
- Flamed Maple top/Nato body
- Medium frets
- B15 bridge (16.5mm string spacing)
- DXH-5N neck pu
- DXH-5B bridge pu
- Phat II eq
- Hardware color : Chrome
- Scale : 864mm/34"
- Colors : TK (Transparent Black)



GSR200EX BKF

- GSR4 Maple neck
- Basswood body
- Medium frets
- B10 bridge (19mm string spacing)
- PPD4 neck pu
- PPD4 bridge pu
- Phat II eq
- Hardware color : Black
- Scale : 864mm/34"
- Colors : BKF (Black Flat)



GSR205EX BKF

- GSR5 Maple neck
- Basswood body
- Medium frets
- B15 bridge (16.5mm string spacing)
- PPD5 neck pu
- PPD5 bridge pu
- Phat II eq
- Hardware color : Black
- Scale : 864mm/34"
- Colors : BKF (Black Flat)

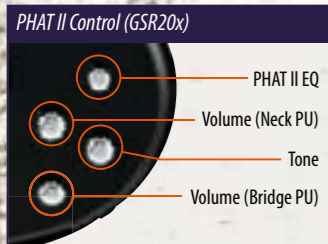

GSR200 PW

- GSR4 Maple neck
- Agathis body
- Medium frets
- B10 bridge (19mm string spacing)
- PSNDP neck pu
- PSNDJ bridge pu
- Phat II eq

- Hardware color : Chrome
- Scale : 864mm/34"
- Colors : BK (Black)
- JB (Jewel Blue)
- PW (Pearl White)
- TR (Transparent Red)

GSR200 TR

- GSR4 Maple neck
- Agathis body
- Medium frets
- B10 bridge (19mm string spacing)
- PSNDP neck pu
- PSNDJ bridge pu
- Phat II eq

- Hardware color : Chrome
- Scale : 864mm/34"
- Colors : BK (Black)
- JB (Jewel Blue)
- PW (Pearl White)
- TR (Transparent Red)

GSR200 JB

- GSR4 Maple neck
- Agathis body
- Medium frets
- B10 bridge (19mm string spacing)
- PSNDP neck pu
- PSNDJ bridge pu
- Phat II eq

- Hardware color : Chrome
- Scale : 864mm/34"
- Colors : BK (Black)
- JB (Jewel Blue)
- PW (Pearl White)
- TR (Transparent Red)

GSR205 BK

- GSR5 Maple neck
- Agathis body
- Medium frets
- B15 bridge (16.5mm string spacing)
- DXH-5N neck pu
- DXH-5B bridge pu

- Phat II eq
- Hardware color : Chrome
- Scale : 864mm/34"
- Colors : BK (Black)
- ROM (Roadster Orange Metallic)

GSR205 ROM

- GSR5 Maple neck
- Agathis body
- Medium frets
- B15 bridge (16.5mm string spacing)
- DXH-5N neck pu
- DXH-5B bridge pu

- Phat II eq
- Hardware color : Chrome
- Scale : 864mm/34"
- Colors : BK (Black)
- ROM (Roadster Orange Metallic)

GSR206 BK

- GSR6 Maple neck
- Agathis body
- Medium frets
- B16 bridge (16.5mm string spacing)
- DXH-6N neck pu
- DXH-6B bridge pu

- Phat II eq
- Hardware color : Chrome
- Scale : 864mm/34"
- Colors : BK (Black)

GIO



GSR100EX TMM

- GSR4 Maple neck
- Mahogany body
- Medium frets
- B10 bridge (19mm string spacing)
- PPD4 bridge pu
- Hardware color : Chrome
- Hardware color : Black
- Scale : 864mm/34"
- Colors : BK (Black)
- SV (Silver)
- TMM (Traditional Matte Mahogany)



GSR100EX SV

- GSR4 Maple neck
- Basswood body
- Medium frets
- B10 bridge (19mm string spacing)
- PPD4 bridge pu
- Hardware color : Chrome
- Hardware color : Black
- Scale : 864mm/34"
- Colors : BK (Black)
- SV (Silver)
- TMM (Traditional Matte Mahogany)



GSR100EX BK

- GSR4 Maple neck
- Basswood body
- Medium frets
- B10 bridge (19mm string spacing)
- PPD4 bridge pu
- Hardware color : Chrome
- Hardware color : Black
- Scale : 864mm/34"
- Colors : BK (Black)
- SV (Silver)
- TMM (Traditional Matte Mahogany)



GSR105EX BK

- 1pc GSR5 Maple neck
- Basswood body
- Medium frets
- B15 bridge (16.5mm string spacing)
- PPD5 bridge pu
- Hardware color : Chrome
- Scale : 864mm/34"
- Colors : BK (Black)



GSRM20 ASM

- GSRM Maple neck
- Basswood body
- Medium frets
- B10 bridge (19mm string spacing)
- STD-P neck pu
- STD-J bridge pu
- Hardware color : Chrome
- Scale : 726.2mm/28.6"
- Colors : ASM (Amethyst Sky Metallic)
- BBM (Brilliant Blue Metallic)
- BK (Black)
- PW (Pearl White)



GSRM20 BK

- GSRM Maple neck
- Basswood body
- Medium frets
- B10 bridge (19mm string spacing)
- STD-P neck pu
- STD-J bridge pu
- Hardware color : Chrome
- Scale : 726.2mm/28.6"
- Colors : ASM (Amethyst Sky Metallic)
- BBM (Brilliant Blue Metallic)
- BK (Black)
- PW (Pearl White)



GSRM20 BBM

- GSRM Maple neck
- Basswood body
- Medium frets
- B10 bridge (19mm string spacing)
- STD-P neck pu
- STD-J bridge pu
- Hardware color : Chrome
- Scale : 726.2mm/28.6"
- Colors : ASM (Amethyst Sky Metallic)
- BBM (Brilliant Blue Metallic)
- BK (Black)
- PW (Pearl White)



GSRM20 PW

- GSRM Maple neck
- Basswood body
- Medium frets
- B10 bridge (19mm string spacing)
- STD-P neck pu
- STD-J bridge pu
- Hardware color : Chrome
- Scale : 726.2mm/28.6"
- Colors : ASM (Amethyst Sky Metallic)
- BBM (Brilliant Blue Metallic)
- BK (Black)
- PW (Pearl White)



GARTB20 TR

- GARTB Maple neck
- Basswood body
- Medium frets
- B10 bridge (19mm string spacing)
- DXH-4N neck pu
- DXH-4B bridge pu
- Hardware color : Chrome
- Scale : 770mm/30.3"
- Colors : BK (Black)
- TR (Transparent Red)



GARTB20 BK

- GARTB Maple neck
- Basswood body
- Medium frets
- B10 bridge (19mm string spacing)
- DXH-4N neck pu
- DXH-4B bridge pu
- Hardware color : Chrome
- Scale : 770mm/30.3"
- Colors : BK (Black)
- TR (Transparent Red)



Size comparison of GSRM20PW (left) to SR700AM

Jumpstart

When we say "Everything you need to get out and gig," we mean everything—amp, axe, accessories. All it takes is you and your desire to make your dreams real—to get out of the audiences and up on stage where you belong.



IJXB190 -Jumpstart-

Features GSR electric bass and Jumpstart bass Package Accessories.

Amplifier

15 watt dedicated bass amp

Package Accessories

- Headphones
- Electronic Tuner
- Gig Bag
- Bass Guitar Strap
- Picks & Cable
- Accessories Pouch



TR

JB

BK



IJMB15 BK -Jumpstart-

Features GSRM miKro electric bass and Jumpstart bass Package Accessories.

Amplifier

10 watt dedicated bass amp

Package Accessories

- Electronic Tuner
- Gig Bag
- Bass Guitar Strap
- Cable



* Contents of packages are subject to change without notice.

There's no substitute for hearing for yourself. When you get a chance, take a trip over to your local Ibanez retailer and try plugging into one of our PRO Series Promethean bass amps. This amazingly versatile combo is built to take a beating and features a removable head that can be used to power a full-size speaker cabinet!

Amplifiers, Effects and Accessories

While you're at it, try out the legendary TS808 Tube Screamer pedal. There's a reason why this little dynamo has continued to be so popular for so long. No matter what your style, the TS808 will enhance your tone and bring out nuances in your playing you didn't know you were capable of.

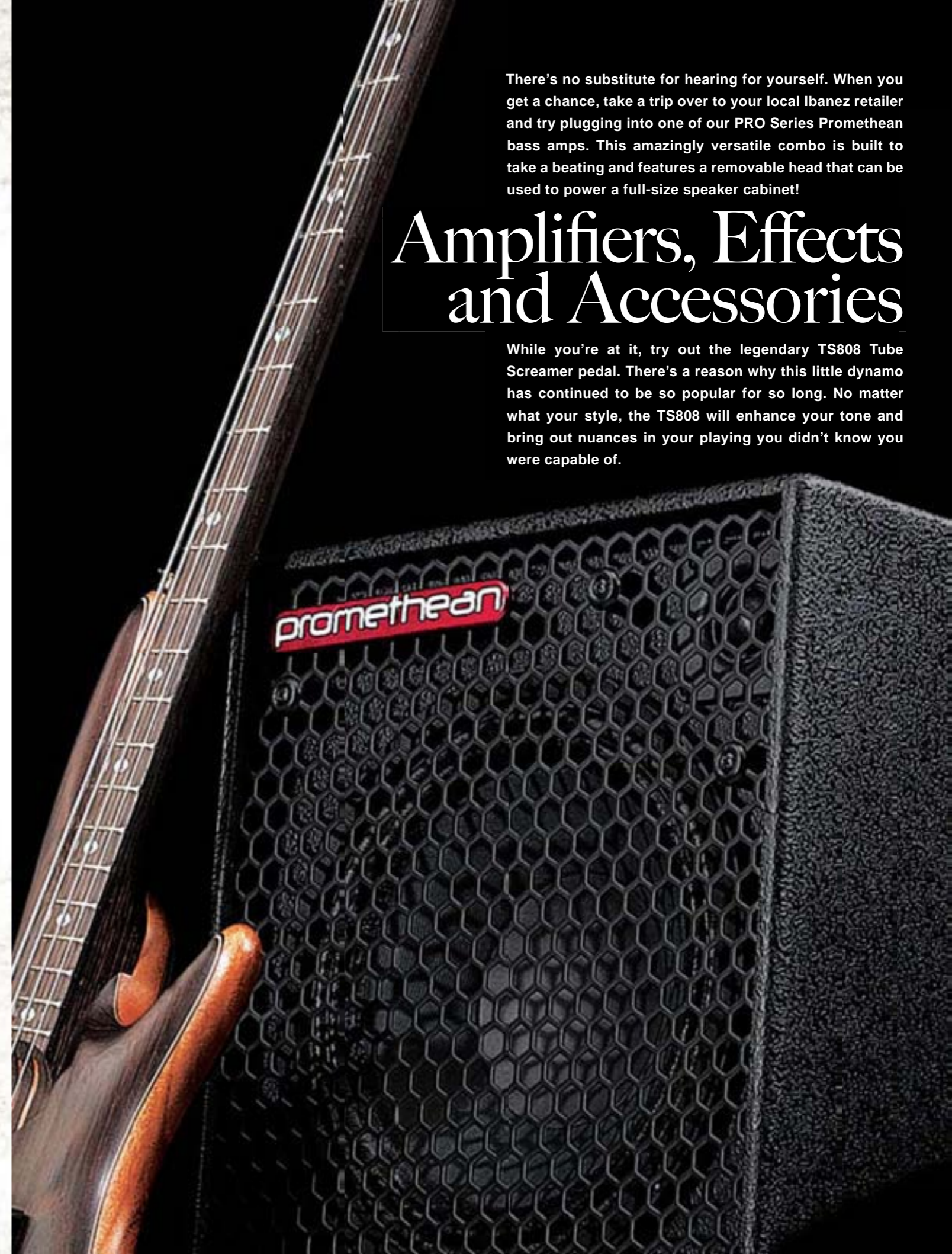

X Tone Blaster

The new generation Tone Blaster X series amps were designed and created to answer the needs of today's guitarist. The parametric mid EQ allows you to dial in any tone you're looking for in an instant. The exclusive X mode allows you to get monstrously heavy and lets you cut through the din of the loudest rhythm section. The gain control in the normal channel can be dialed down to give you anything from a clean jazz tone to a crunchy, slightly overdriven rock'n roll tone. Plug in and express yourself with TBX.

MIMX

Traditional companies provide versatility and warm vintage tones with their modeling amps, but only Ibanez brings you the same versatility plus the heavy, searing modern tones required by today's players. The MIMX amps offer a wider variety of distortion and overdrive than any other modeling amp currently available, and there's still plenty of classic and clean tones to get you through any gig.



TBX150H 150W Guitar Amplifier

- output power 150W@4Ω
- controls Normal Channel - Overdrive Switch, Gain, Bass, Middle, Treble, Volume, Reverb Level
Hot Channel - X Mode Switch, Gain, Bass, Middle Frequency, Middle Level, Treble, Volume, Reverb Level, Channel Switch, Hue
- i/o's Input, Send, Return, 2 x Speaker Output, Footswitch 1 & 2
- cabinet W/Accessory Box
- size 25.0"(W) x 9.9"(D) x 10.2"(H)
- weight 31.1 lbs

IS412CS Speaker Unit

- speaker unit 4 x 12" Ibanez IS1216G
- power handling 320Wrms/640Wmax
- i/o's 2 x Input (4Ω&16Ω)
- cabinet IS412CA : Traditional Angled
IS412CS : Straight Front Angled
- size 27.8"(W) x 13.1"(D) x 29.7"(H)
- weight 75.1 lbs

*Also Available IS412AS w/Angled Front

TBX150R 150W Guitar Amplifier

- output power 150W@4Ω
- speaker unit 2 x 12" Ibanez IS1208G
- controls Normal Channel - Overdrive Switch, Gain, Bass, Middle, Treble, Volume, Reverb Level
Hot Channel - X Mode Switch, Gain, Bass, Middle Frequency, Middle Level, Treble, Volume, Reverb Level, Channel Switch, Hue
- i/o's Input, Send, Return, Speaker Output, Footswitch 1 & 2
- cabinet Closed Back Cabinet
- size 26.3"(W) x 10.8"(D) x 19.7"(H)
- weight 54.1 lbs



X Mode/Channel

The X mode/channel emphasizes tighter low end and a unique tonality in the midrange, which increases sustain and harmonics.



TBX65R 65W Guitar Amplifier

- output power 65W@4Ω
- speaker unit 12" Ibanez IS1204G
- controls Normal Channel - Overdrive Switch, Gain, Bass, Middle, Treble, Volume, Channel Switch
Hot Channel - X Mode Switch, Gain, Bass, Middle Frequency, Middle Level, Treble, Volume, Reverb Level
- i/o's Input, CD/MP3 In, Footswitch, Headphones
- cabinet Closed Back Cabinet
- size 19.3"(W) x 10.0"(D) x 17.8"(H)
- weight 39.1 lbs



TBX30R 30W Guitar Amplifier

- output power 30W@8Ω
- speaker unit 10" Ibanez IS1008G
- controls Normal Channel - Gain, Volume, Channel Switch
X Channel - Gain, Volume
- i/o's EQ - Bass, Middle Frequency
Middle Level, Treble, Reverb Level
Input, CD/MP3 In, Footswitch, Headphones
- cabinet Open Back Cabinet
- size 17.3"(W) x 8.7"(D) x 16.3"(H)
- weight 18.3 lbs



TBX15R 15W Guitar Amplifier

- output power 15W@4Ω
- speaker unit 8" Ibanez IS804
- controls Normal Channel - Gain, Volume, Channel Switch
X Channel - Gain, Volume
- i/o's EQ - Bass, Middle Frequency
Middle Level, Treble, Reverb Level
Input, CD/MP3 In, Headphones
- cabinet Closed Back Cabinet
- size 14.4"(W) x 7.9"(D) x 13.8"(H)
- weight 16.1 lbs



MIMX150H

150W Fully Digital Modeling Head

- 150 watt @ 4 ohms
- Fully digital programmable preamp with 11 amp models
- 10 memory locations
- 50 rhythm patterns
- 13 digital effects
- Accessory compartment
- 25.0"(W) x 9.9"(D) x 10.2"(H)
- Weight : 30.7lbs

- 11 amp models with the widest amp/tonal type variation available. Features ten of the classic British, American and boutique amp models plus a new and original Ibanez high-gain "Psycho" model.
- 10 programmable patches! Any combination of settings can be auditioned and adjusted in real time and then saved to any one of the 10 memory locations. This includes amp model, equalization setting and digital effects and their particular parameters.
- 50 rhythm patterns. Wide range of rhythms for any kinds of practice, recording or single gig : metal, Latin, hip-pop, ballad, shuffle, hard rock and much more.

- 13 digital effects (up to three effects simultaneously): including five Expression Pedal-type Effects Accessible via the OPTIONAL Pedal Controller : VOLUME, RING MODULATOR, AUTO RESONANCE, WAH-WAH and PITCH SHIFT.
- You can choose one of the four Modulation Type Effects : CHORUS, FLANGER, VIBRATO or STEP.
- And one of Delay/Reverb Type Effects : DELAY, ECHO, HALL or ROOM REVERB.
- Plus a built-in fully chromatic tuner!



MIMX65 65W Fully Digital Modeling Combo

- 65 watt guitar amp
- 12" Ibanez IS1204G speaker
- Fully digital programmable preamp with 11 amp models
- 10 memory locations
- 50 rhythm patterns
- 13 digital effects
- Chromatic Tuner
- 1/4" CD/MP3 input jack
- 1/4" headphones/record out jack
- Closed-back Cabinet design
- 19.3"(W) x 10.0"(D) x 17.8"(H)
- Weight : 35.8 lbs



IFC2 Effects Foot Controller

The PEDAL FX section is ONLY accessible using the optional Ibanez IFC2 Foot Controller for MIMX150H/MIMX65. (The IFC2 is sold separately.)



IFS4X Footswitch Controller

Latching 4-button footswitch with metal housing for use with the TBX150H/TBX150R.



IFS2X Footswitch Controller

Latching footswitch with metal housing for use with the TBX30R, TBX65R and T35.



IBZ10G Guitar Amplifier

- output power 10W@8Ω
- speaker unit 6.5" speaker
- controls Overdrive On/Off Switch, Gain, Bass, Middle, Treble, Volume
- cabinet Closed-Back Cabinet
- size 10.8"(W) x 7.9"(H) x 12.3"(D)
- weight 11.7 lbs

IBZ10G offers the famous Tone Blaster distortion sound, at an affordable price. Its closed back cabinet and redesigned 6.5" Power Jam speaker will produce heavy tones, while the 3-band active EQ opens up more sound versatility. Also includes inputs for playing music from CD players or rhythm machines.

IBZ



6 Band Graphic EQ

Promethean series amps feature 6-band Graphic EQ that allows you to make precise tonal adjustment in any type of environment. Each frequency is carefully selected to be the most demanded by bass players. The 6-band EQ can be bypassed by a selected switch.



Vibe Control

Control tonal character from creamy vintage sounds to modern sounds. Also, the On/Off push switch allows you to change playing character, from walking to picking and/or slapping, instantly. (On/off can be controlled by optional IFS2X footswitch.)



Aux/Phones

The included aux input allows you to play along with a connected MP3 or CD player. With headphone out, it's great for bedroom jam sessions or sound check at rehearsals.



Line Out

The balanced XLR output sends a balanced signal to the mixing console and/or main PA system in any live or studio situation. Pre- or Post EQ switchable and GND Lift switch-equipped along with switchable level control to avoid ground loops with other connected equipment.

Speak Loud And Carry A Small Amp

promethean

Ibanez Bass Amplifiers

One might never imagine that a small amp could produce big sound, but in terms of the Ibanez Promethean Bass amp series, that is not the case. The Promethean series amp is designed for busy working musicians who travel around from one venue to the next. Within its compact body, the Promethean features CRITICAL functions in order to deal with various situations and requirements in a live environment. It also gets LOUD!!! The working musician has it easy with the Promethean amp, a dependable workhorse of an amp.



Detachable Amp Head (P5110/P5210)

The P5110 and P5210 amp head can be easily detached without any tools. Due to its compact size, it's efficient to take it out anywhere you need to go.

P5110 Bass Combo Amplifier

- output power 250W@8Ω/500W@4Ω
- speaker unit 10" Ceramic Speaker, Dome Tweeter
- controls Mute Switch, Gain, Low/High Control, 6 Band Graphic EQ, Vibe Control, Master Volume
- i/o's Input, Aux Input, Phones Out, Tuner Out, Balanced Line Out (XLR), Footswitch Jack (Mute/Vibe)
- cabinet Ported Bass Reflection Cabinet/Tilt-up System
- size 12.8"(W) x 13.1"(D) x 14.2"(H)
- weight 27.6 lbs

The P5110 delivers 250W@8Ω while used individually. When used with the P110C speaker cabinet, it delivers 500W@4Ω in total.



IFS2X Footswitch Controller

Latching footswitch with metal housing for use with the P500H and P5110. (The IFS2X is sold separately.)

P500H Bass Amplifier Head

- output power 250W@8Ω/500W@4Ω
- controls Mute Switch, Gain, Low/High Control, 6 Band Graphic EQ, Vibe Control, Master Volume
- i/o's Input, Aux Input, Phones Out, Tuner Out, Balanced Line Out (XLR), Footswitch Jack (Mute/Vibe)
- size 11.0"(W) x 2.2"(H) x 10.4"(D)
- weight 6.4 lbs

P5210 Bass Combo Amplifier

- output power 500W@4Ω
- speaker unit 2 x 10" Ceramic Speaker, 2 x Dome Tweeter
- controls Mute Switch, Gain, Low/High Control, 6 Band Graphic EQ, Vibe Control, Master Volume
- i/o's Input, Aux Input, Phones Out, Tuner Out, Balanced Line Out (XLR), Footswitch Jack (Mute/Vibe)
- cabinet Ported Bass Reflection Cabinet
- size 13.1"(W) x 30.3"(D) x 14.8"(H)
- weight 54.7 lbs

A bass combo amplifier with 2 x 10" speakers and 500W. It performs Perfectly in any situation regardless of the venue, from a small pub to a larger club situation. The head is detachable from cabinet, so you can carry it around and use just the head.

P115C Speaker Cabinet

- 300W
- 15" Neodymium Speaker
- Horn Tweeter
- P115C 2 x SPEAKON® Combo Jack
- Ported Bass Reflection Cabinet
- 23.8"(W) x 17.7"(D) x 24.4"(H)
- 54.7 lbs

P110C Speaker Cabinet

- 250W
- 10" Neodymium Speaker, Dome Tweeter
- SPEAKON® Combo Jack
- Ported Bass Reflection Cabinet/Tilt-up System
- 12.8"(W) x 12.8"(D) x 18.1"(H)
- 21.0 lbs

P410C Speaker Cabinet

- 1000W
- 4 x 10" Neodymium Speaker
- Horn Tweeter
- P410C 2 x SPEAKON® Combo Jack
- Ported Bass Reflection Cabinet
- 23.8"(W) x 17.7"(D) x 24.4"(H)
- 75.7 lbs

BGP500 Carry Bag

Bag for P500H. (P500H head sold separately.)

BGP511 Carry Bag

Bag for P5110. (P5110 amp sold separately.)

*SPEAKON® is a registered trademark of Neutrik AG

SOUND WAVE

The SWX Sound Wave Bass amp series is designed for any bass players who want serious versatility. The SWX delivers a thick, natural and balanced tone, while its perfect combination of function allows you to change the tonal character without any hassle. Playing the Sound Wave will give you what you need for the groove, the drive, the pocket and the tones - whether you need traditional thump or today's pop, slap and funk.



Shape Switch

Create the hi & low boost / mid cut sound instantly, which is one of the most desirable tones for many bass players.



Bright Switch

Selectable Normal and Bright modes change the sound character immediately, from the tone of passive bass to that of active bass.



Internal Auto Compression Circuit

All Sound Wave SWX series bass amplifiers are equipped with internal auto compression circuitry, which minimizes distortion and keeps the sound clean and powerful. (LED included on all models except SWX20)



HUE Control

All Sound Wave SWX series bass amplifiers feature the HUE control, which adjusts overall tonal character.

SWX35

35W Bass Amplifier

- output power 35Watts
- speaker unit 10" Coaxial 2Way Bass speaker
- controls Shape Switch, Bright Switch, Gain Level, Bass, Middle, Treble, Hue, Master Volume, Auto-comp w/LED
- i/o's Input, CD / MP3 Input, Line Out, Headphones
- cabinet Sealed Back Cabinet w/Tilt-Up System
- size 14.9"(W) x 21.0"(H) x 12.3"(D)
- weight 31.4 lbs

SWX100

100W Bass Amplifier

- output power 100Watts
- speaker unit 15" Bass speaker with Piezo Horn Tweeter
- controls Shape Switch, Bright Switch, Gain Level, Bass, Middle, Treble, Hue, Master Volume, Tweeter Switch, Auto-comp w/LED
- i/o's Input, CD / MP3 Input, Direct Out w/Post EQ Switch & GND Lift Switch, Effects Loop, Headphones
- cabinet Sealed Back Ported Bass Reflection Cabinet w/ Caster
- size 20.5"(W) x 26.9"(H) x 12.3"(D)
- weight 53.4 lbs



SWX65

65W Bass Amplifier

- output power 65Watts
- speaker unit 12" Bass speaker with Piezo Horn Tweeter
- controls Shape Switch, Bright Switch, Gain Level, Bass, Middle, Treble, Hue, Master Volume, Tweeter Switch, Auto-comp w/LED
- i/o's Input, CD / MP3 Input, Line Out, Effects Loop, Headphones
- cabinet Sealed Back Bass Reflection Cabinet w/Tilt-Up System
- size 16.6"(W) x 24.9"(H) x 12.3"(D)
- weight 41.5 lbs

SWX20

20W Bass Amplifier

- output power 20Watts
- speaker unit 8" Coaxial 2Way Bass Speaker
- controls Shape Switch, Bright Switch, Gain Level, Bass, Middle, Treble, Hue, Auto-comp
- i/o's Input, CD / MP3 Input, Headphones
- cabinet Sealed Back Cabinet
- size 13.2"(W) x 16.1"(H) x 9.4"(D)
- weight 18.9 lbs



Photo by Michael Mesker



Jemini distortion



Steve Vai's Signature Distortion Pedal with overdrive and distortion in one package. Featuring a rigid aluminum case, magnificent LED lights around the knobs, and a unique multicolor case with Vai logo rubber foot pedals. The JEMINI's meant to be seen and heard.

TUBE KING

Tube King is the regal name in distortion pedals. Both the TK999HT Distortion and the TK999OD Overdrive pedals feature internal high voltage DC power - the best for making any solid-state amp sound just like a tube amp. TK999HT's distortion is massive yet tight. The TK999OD Overdrive will give you anything from light break-up to super smooth hi-gain saturation. Both pedals are very versatile, with tone knobs to allow you plenty of play in shaping the tone you're looking for. And both include actual tubes!



TK999HT Tube King Distortion

- Genuine High Voltage Tube Distortion
- Actual 12AX7 Tube
- Active EQ plus Presence Switch
- VOID Control
- AC Adapter included

TK999OD Tube King Overdrive

- Genuine High Voltage Tube Overdrive
- 3 band EQ with presence
- Gain and level controls
- Hi/Lo input switch
- AC Adapter included



IBZ

IBZ10B

Bass Amplifier

- output power 10W@8Ω
- speaker unit 6.5" speaker
- controls Bass, Middle, Treble, Presence, Volume, Bass Input, Headphone
- cabinet Closed-Back Cabinet for "phatter" bass tone
- size 11"(W) x 12.5"(H) x 8.0"(D)
- weight 13 lbs

IBZ10B is 10W amplifier designed for bass guitars. It is equipped with 3 band EQ and presence control for responding to every bass guitars. Its closed back cabinet and 6.5" Power Jam speaker give accent to primary bass sound.



WH10V2

Classic Wah Pedal

- Multiple feedback opamp circuit
- Depth knob(+6 - +12db)
- Range switch
- (guitar 350Hz - 2.2kHz)
- (Bass 175Hz - 1.1kHz)
- Dry Out
- Die-cast case



WH10V2

The WH10V2 features the same multiple feedback opamp circuit as the original, a feature rarely found in today's wah pedals. It also has a depth knob to control to level of the wah effect and a dry out for mixing a dry signal with the wah sound. The WH10V2 has a unique tone character setting it apart from all traditional wah pedals, as well as some modern tweaks so your sound keeps changing with the times.

The upgrade you will notice is the die-cast metal construction, replacing the original plastic case. Feel free to dance on this sucker now—it can take anything you dish out.



AIRPLANE FLANGER

The Paul Gilbert Signature AF2 AIRPLANE Flanger is two pedals in one package. One section is a traditional chorus flange (TAXI); the other is an insane (TAKEOFF) flange (hence the "AIRPLANE" moniker), which provides virtuoso guitarist Paul Gilbert's own "Crazy Flange" sound. Time to buckle up. The AF2 features Manual (delay time), Speed (modulation speed), Range (depth of modulation), and Enhance (feedback) controls.



CLASSICS

Sometimes it's best to keep it simple. Which is why, in a world of dizzying often over-complex technology, the durable, dependable and simple stompbox continues to be the most widely used and effective means to expand, color, distort, mutate, sustain and twist tone.



TS808HW Hand Wired Tubescreamer

The Ibanez Tubescreamer, in its many versions and forms, can be found on pedal boards in every corner of the globe, on arena stages and in small studios and bedrooms. Its warm overdrive is a sound many players, from advanced to beginner, could never do without. Now, it gets even better with the release of the TS808HW, a Hand-Wired deluxe Tubescreamer built with the pro musician in mind. Encased in a special, heavy duty metal box, the TS808HW is Hand-Wired with select JRC4558D chips (same as the revered and often imitated TS808) and uses Japanese high-end MOGAMI OEC cable (AWG21). Equipped with True Bypass, this Tubescreamer sends pure guitar excitement to your amplifier with no tonal loss whatsoever. This is, by far, the most evolved Tubescreamer ever created.

TS808 The Original Tubescreamer

Modeling and boutique pedal makers have copied the smooth and full tone of this pedal countless times. Now you can have Ibanez's faithful reissue at a price that doesn't break the bank. The reissue features the same JRC4558D IC chip and analog circuitry as the original. Controls include overdrive, level, and tone controls.



FL9 Flanger

Same circuitry and coveted flanging effects of the original '80s unit but constructed to closer tolerances for more consistency from unit to unit. If you've been hunting for an original but couldn't find one, or couldn't afford a high asking price, now's your chance to bag this '80s favorite. Might even be better than the original.



AD9 Analog Delay

The Ibanez AD9 Analog Delay Effect Pedal uses a compander with pre- and de-emphasis for an exceptionally clean delay. Time and level controls allow mixing between dry and delayed signals. Repeat control lets you adjust the number of repeats without runaway. 2 outputs enable dry and delayed signals to be routed separately.



TS9 Tubescreamer

The Ibanez TS9 Tubescreamer is a reissue that's just like the original in so many ways. Same factory, same components, same housing, same famous seasick-green paint, and the same crankin' overdrive that made the original one of the all-time classic pedals. Guitar Player called it the best. Plug it in. Crank it up. You'll hear what all the fuss is about. Tone, drive, and level controls.



TS9DX Turbo Tubescreamer

The Ibanez TS9DX Turbo Tubescreamer Effects Pedal features the same circuit as a TS9 Tubescreamer and also offers 3 new settings for increased low end crunch: +, Hot, and Turbo.



CS9 Stereo Chorus

When it comes to compact effects, nine is the magic number. By popular demand (and the understandably escalating prices of the originals), Ibanez has reissued its popular CS9 chorus featuring the original circuitry. If you missed out on getting one of these classics the first time around, now is your chance.



WD7JR Weeping Demon Junior

A more affordable version of our WD7 pedal, the WD7JR presents a high quality wah-wah pedal at a great price. Activates with minimal pedal pressure. Auto Off Delay control allows you to delay the end of wah-wah effect after your foot leaves the pedal, for smooth transition and phrasing. Features a maintenance-free optical sensor – no need to worry about producing unwanted noise from the volume pot. Also includes Level control for volume adjustment.



TONE-LOK

EFFECTS PEDALS

On the outside, Tone-Lok effects are equipped with our exclusive "set and forget" Push-Lok rotary pots. Push the knobs down and your tone settings lock securely inside the case. No more lost settings or knobs broken. On the inside, Tone-Lok pedals feature hi-fidelity components carefully tweaked with the constant input from a new generation of Ibanez players. And all this great stuff comes encased in cool looking, road-tough metal boxes at prices the working player can afford.



AP7 Analog Phaser

The addition of the AP7 to the Tone-Lok series has brought with it the warm midrange sounds of a true Analog Phaser. The pedal features speed, depth, and feedback controls as well as a 3-way switchable phase circuit. When switched to 4-stage phasing, the pedal recreates the sounds of a vintage phaser. When switched to 8-stage phasing, the pedal produces more aggressive and deep phasing characteristic of modern pedals. This setting works best on more distorted lead sounds.



TC7 TRI-Mode Chorus

Are you bored with normal chorus pedals? If so, the Ibanez TC7 will bring the thrill back. The TC7 can create three types of chorus with the combination of two individual chorus circuits. It truly expands your guitar's expressiveness.



SM7 Smash Box

The Smash Box is the most aggressive weapon in the Tone-Lok distortion arsenal. Armed with obscene amounts of gain, tight low end, and searing highs, the Smash Box is the heavy rock sound for the contemporary guitarist. Special "VOID" noise gate and "EDGE" (sharp/smooth) controls let you handle anything from all-out shred to machine-gun metal riffs and rhythms.



DS7 Distortion

The most versatile Ibanez distortion pedal ever, capable of producing a wide range of smooth, dynamic overdrive tones. From a subtle tonal nudge to walloping rock'n'roll crunch, the DS7 delivers days of sustain and gobs of gain.



TS7 Tubescreamer

The Tubescreamer isn't just a stompbox, it's an institution. Our latest generation Tubescreamer, the TS7, is no exception. With the Tubescreamer's classic subtle-but-smooth overdrive, the TS7 expands the expressiveness of your guitar while maintaining its tonal integrity. Tone adjustments are provided by the classic three knob configuration with an added "hot" switch for an extra gain boost.



FZ7 Fuzz

Far out! A complete 60's flashback with none of the drawbacks, the FZ7 is the ultimate in psychedelic fuzz. With the FZ7's tone, drive, and level controls, it's never been easier to get the right retro tones. You can even engage the DAMAGE switch for that ratty, broken speaker sound. Yeah, baby, yeah! Dial in, tune up, drop down or whatever turns you on.



DE7 Delay/Echo

Add new dimensions to your sound with the DE7 Delay/Echo pedal. Get the best of both worlds: high tech digital sounds comparable to expensive rack units or warm vintage tape echo sounds – all with a simple flick of the switch. TIME, REPEAT and LEVEL controls help you dial in just the right amount of delay, while stereo outputs can be used for a more spacious sound. With a range of 30ms to 2.6 seconds, the DE7 is the only sound solution for every playing situation.



CF7 Chorus/Flanger

The Ibanez CF7 Tone Lok stompbox is highly versatile, capable of producing vintage chorus, flange, and modern modulation guitar effects, everything from shimmering soundscapes to jet plane whooshes. A Crazy switch lets you choose between normal and whack'd modes.



PM7 Phase Modulator

If you've gone through one phase after another, maybe it's time for the final phase. The PM7 Phase Modulator offers three types of waveforms to give you everything from classic phaser to DJ effects to toy ray gun sounds. Since good things come in threes, the PM7 also has three phase stages: vintage, deep and dry, and deep and pronounced. With some minor tweaking, the PM7 goes from traditional to 21st century and beyond.



WD7 Weeping Demon

The Ibanez WD7 Weeping Demon Wah Pedal will have your audience screaming for more with its shrieks, cries, wails, and seductive siren songs. Among its features are spring and normal footboard action, selectable wah range, and fine tuning controls.



AW7 Autowah

There are autowahs. And there are autowahs. But the Tone-Lok AW7 isn't just any autowah. It's got standard wah where both the highs and lows are cut and it's got a wah setting where only the highs are cut. And it's got distortion. Band Pass Filter provides the sound of a standard wah pedal left at one setting (a favorite wah pedal technique of Joe Satriani). You can even change the chain order of the effects to get different tones: either distortion to wah or wah to distortion.



LF7 Lo Fi

The first dedicated filter pedal for the guitar, the LF7's voltage controlled analog high and low pass filters allow you to emulate transistor radio and megaphone type sounds. Best used at the end of a signal chain in combination with other pedals, this ticking time bomb creates wide soundscapes of far out tones that previously required a massive rack of analog electronics. The Lo Fi also performs equally well with vocals, drum machines or in any "mix-down" context.



PD7 Phat-Hed Bass Overdrive

Why let guitarists rule the stage? Loaded with growling low-end distortion, the PD7 levels the playing field for the rock bassist. The PD7 is armed with three pre-amp style voicings and an attack control switch, which accents the amount of harmonic content in your sound. With DRIVE, LO, HI, and LEVEL knobs, dialing in a thunderous bass sound has never been easier.



SB7 Synthesizer Bass

If you're looking for new tones or you're still smoldering with resentment against synth bass keyboard players, the SB7 is the ticket. You've got real time feel—in other words no annoying tracking errors and delays. You can even play chords.

CABLES

Series DS Low Noise Cable

- 10-year replacement warranty.
- "Basic" in price only.
- DS cable offers pro-quality and durability at standard cable prices.
- Double-shielded construction.



Speaker Cables Series DS Professional

- 10-year replacement warranty.
- "Basic" in price only.
- DS cable offers pro-quality and durability at standard cable prices.
- Low Noise.



Series DS Microphone Cables

- 10-year replacement warranty.
- "Basic" in price only.
- DS cable offers pro-quality and durability at standard cable prices.
- Double-shielded construction.
- Low Noise.



Item #	Double Shielded Cable	Specifications
DSC05LL	0.5' Cable	0.5'/2 Right Angle Plugs
DSC08LL	0.8' Cable	0.8'/2 Right Angle Plugs
DSC6	6' Cable	6'/2 Straight Plugs
DSC6L	6' Cable	6'/Straight & Right Angle Plugs
DSC10	10' Cable	10'/2 Straight Plugs
DSC10L	10' Cable	10'/Straight & Right Angle Plugs
DSC10BK	10' Woven Cable	10'/2 Straight Plugs
DSC10RD	10' Woven Cable	10'/2 Straight Plugs
DSC10BL	10' Woven Cable	10'/2 Straight Plugs
DSC10LL	10' Cable	10'/2 Right Angle Plugs
DSC15	15' Cable	15'/2 Straight Plugs
DSC15L	15' Cable	15'/Straight & Right Angle Plugs
DSC15LL	15' Cable	15'/2 Right Angle Plugs
DSC20	20' Cable	20'/ 2 Straight Plugs
DSC20BK	20' Woven Cable	20'/ 2 Straight Plugs
DSC20RD	20' Woven Cable	20'/ 2 Straight Plugs
DSC20BL	20' Woven Cable	20'/ 2 Straight Plugs
DSC20L	20' Cable	20'/ Straight & Right Angle Plugs
DSC20LL	20' Cable	20'/ 2 Right Angle Plugs
DSC25	25' Cable	25'/ 2 Straight Plugs
DSC25L	25' Cable	25'/ Straight & Right Angle Plugs
SPCPP6	6' Speaker Cable	6'/2 Straight Plugs
SPCPP10	10' Speaker Cable	10'/2 Straight Plugs
SPCPP25	25' Speaker Cable	25'/2 Straight Plugs
SPCPP50	50' Speaker Cable	50'/2 Straight Plugs
MCCC10	10' Microphone Cable	10'/2 XLR Plugs
MCCC20	20' Microphone Cable	20'/2 XLR Plugs
MCCC50	50' Microphone Cable	50'/2 XLR Plugs

TUNERS

When you make 6-string, 7-string and 8-string guitars for players who use all kinds of alternate tunings, you'd better be very serious about tuning. We are. Our wide variety of compact tuners offer strict accuracy, easy operation and our famous Ibanez reliability.



LU20

LU20 BK

LU20

Pedal Tuner

This tuner features a durable diecast housing and LED display with a three-color indicator for maximum visibility from the floor.

Clip Tuner

Both Ibanez clip tuners, PU20 and PU10, are designed to tune electric and acoustic guitars, basses, violins, banjos, mandolins, and more without interference from ambient room noise. It does it all without the use of wires, microphones or pickups. Tuning in noisy environments is a snap because the unique, flexible clamp actually feels the instrument's vibration instead of relying on sound. PU20 features backlit large LCD display for maximum visibility even in the dark stage. PU10 features the 4 hinges that allow a perfect view of the tuner's LED display from nearly any angle.

* PU10 is available in black or silver.



PU20

PU10 SL

PU10



RU10

RU10 WH

RU10 RD

RU10

Jam Tuner

There is no doubt that tuning is important. However it is just preparation, when your goal is to be playing guitar and having fun. With the Ibanez RU10, Jam Tuner, you can do both without firing up your amp. Besides functioning as a chromatic tuner, the RU10 combines a metronome and the Rhythm Play function that features preset rhythm patterns to play along with. The gain control enables you to produce an amazing, real deal distortion sound out of the built-in speaker, letting you jam right away.



LU10

Chromatic Tuner

This tuner is designed for electric guitars and basses, as well as acoustic guitars. The clever LU10 is an easy-to-use tuner with an LED display including a large, bright note display. It's very easy to work with.



GU1

GU1 SL

GU1

Automatic Tuner

The GU1 is the first guitar/bass auto tuner with strobe display mode. Strobe pattern flashes in a circular motion when you're in tune. Also includes regular needle display mode function. Simple operation, good for beginners also.



GU40 BL

GU40 RD

GU40 SL

GU40

Automatic Tuner

The colorful GU40 guitar tuner from Ibanez features hands-free tuning. This no hassles auto tuner is fast and accurate and works with guitar, bass or almost anything that shares the same tuning. It even has seven tuning notes for 7-string guitars. The GU40 guitar tuner has a built-in mic for fast and accurate metering.



CU40

Chromatic Tuner

The CU40 chromatic guitar tuner from Ibanez is fast and accurate and works with guitar, bass or almost anything else. The CU40 has a large LCD display, LED 'flat' and 'sharp' guide lights and a built-in mic for fast and accurate metering.



MU40

Metronome Tuner

The dual purpose Ibanez MU40 Tuner/Metronome indicates pitch with both an LCD needle display plus red flat and sharp LEDs plus a green in-tune LED. Designed for electric guitars, basses and acoustic instruments. Built-in metronome with speaker, mute switch, and headphone input. Ideal for teachers and students.

CASES & GIG BAGS

Only Ibanez cases and bags are made to fit the unique shapes of Ibanez guitars and basses. If it doesn't say Ibanez on the case or bag, it's not an Ibanez.

Guitar Case Item #	Models
UV1000C	for RG, RGA, RGD 6-strings, GRG, GRGA
M100C	for RG, RGA, RGD 6-strings, GRG, GRGA, S, SA, GSA, JS
RG550LC	for RG, RGA, RGD 6-strings, GRG, GRGA, S, RG left handed
RG140C	for RG, RGA, RGD, GRG, GRGA, GRX, GSA
XP100C	for XP
AR100C	for ARX, ART, GART, GART left-handed
ICT100C	for ICT
JTK100C	for JTK
NDM1000C	for NDM2
AM50C	for AR
W50DNT	for DN
DTT100C	for DTT

Box Guitar Case Item #	Models
AF100C	for AF, AK
AF200C	for AF, AK
AG100C	for AG
AFS100C	for AGS
AM100C	for AM, AMF
AS100C	for AS, AFS
AS200C	for AS, AFS
GB10SC	for AG, GB



Bass Case Item #	Models
MB100C	for SR, SRX, SRT, SRA, PRB, MDB
EXB1000C	for SR, SRX, SRT, SRA, PRB, MDB, GSR
ATK1000C	for ATK, BTB, PGB
ICB100C	for ICB, SDB
JTKB100C	for JTKB, ARTB, GARTB
AGB100C	for AGB
AFB100C	for AFB



PICKS



Ibanez picks feature traditional styles, artist signature models and special no-slip "Grip Wizard" picks.

Signature Picks	Item #	Color	Thickness	Material
Steve Vai	B1000SV	Brown/Green/Pink	HEAVY	POLYACETAL
Steve Vai	B1000SVR	White	HEAVY	POLYACETAL
Paul Gilbert	B1000PG	Black/Candy Apple*/Jewel Blue/Pearl White	HEAVY	CELLULOID *PVC

Series	Item #	Color	Thickness	Material
Sand Grip Wizard	BPA16HS	Black/Blue/Red/White	HEAVY	POLYACETAL
	BPA16MS		MEDIUM	
Rubber Grip Wizard	BPA16HR	Black/Blue/Red/White	HEAVY	POLYACETAL
	BPA16MR		MEDIUM	
Standard ART Picks	BTL16H	Black/Orange or Red*/Clear/Green/Blue/White	HEAVY	CELLULOID *PVC
	BTL16M		MEDIUM	
	BIB16H		HEAVY	
	BIB16M		MEDIUM	
	BCI16M		MEDIUM	
Standard Celluloid	BCE16H	Black/Hair-lined Gold/Tortoiseshell/White	HEAVY	CELLULOID
	BCE16M		MEDIUM	
	BCE4T	Pearl/Tortoiseshell	THIN	

Standard Bags

Newly upgraded standard bags from Ibanez. Improved strap angle, thick shoulder pad and waist belt all combine to make your gear feel lighter than ever.

ISGB501-BK	Bag for El. guitar
ISBB501-BK	Bag for El. bass



GBP
Combination bag features a separable backpack and heavy-padded gig bag.

BBP
Combination bag features a separable backpack and heavy-padded gig bag.

IDGB5/Double Gig Bag
• Carries two axes
• Includes wheels
• Able to stand independently

IBB7 Deluxe Bass Gig Bag
• Includes slide-out laptop bag

IGB7 Deluxe Guitar Gig Bag
• Includes slide-out laptop bag

IDBB5/Double Gig Bag
• Carries two basses
• Includes wheels
• Able to stand independently

GBMIKRO
Mikro Guitar Bag

BGBMIKRO
Mikro Bass Bag

STRAPS

Heavy duty combination cloth/leather Ibanez straps offer a 70" maximum length.



GS60CIBR
GS60CISL
GS60STGY
GS60STRD

GS60LWR
GS60LMG
GS60LDB
GS60LKI
GS60LBK

LS65TLBKS

LS65TLBRE

LS65TLWHD

IS5BK

Pickup Specifications

MODEL NO.	NAME	RECOMM. POSITION	CONSTRUCTION	MAGNET	DESCRIPTION KEY
					RECOMMENDED POSITION B : BRIDGE, M : MIDDLE, N : NECK CONSTRUCTION H : HUMBUCKING, S : SINGLE COIL BASS ONLY/A : ACTIVE, P : PASSIVE MAGNET AL : ALNICO, C : CERAMIC
IBANEZ GUITAR PICKUPS					
ACH-BL	ACH-BL	B	H	C	Single coil sized blade humbucking pickup. Sound in-between humbucking and single coil.
ACH1	ARTCORE 1	N	H	C	Clean sounding with a slight overdrive.
ACH2	ARTCORE 2	B	H	C	Bridge version of ACH1.
ACH3	ACH3	N	H	C	Well-balanced classic humbucker tone.
ACH4	ACH4	B	H	C	Well-balanced classic humbucker tone.
ACH1-5	ACH1-S	N	H	C	Tight tone with added treble.
ACH2-5	ACH2-S	B	H	C	Bridge version of ACH1-S.
AH1	AXIS HUMBUCKER 1	N	H	C	Very responsive and full sounding; medium output with lots of character. Excellent for chording.
AH2	AXIS HUMBUCKER 2	B	H	AL	Full bass sound. Alnico-5 magnet provide excellent clarity in harmonics and individual notes.
AH5	AXIS HUMBUCKER 5	N	H	C	Very responsive and full sounding; medium output with lots of character. Excellent for chording.
AH6	AXIS HUMBUCKER 6	B	H	AL	Full bass sound. Alnico-5 magnet provides excellent clarity in harmonics and individual notes.
AH1-7	AXIS HUMBUCKER 1-7	N	H	C	Seven-string version of AH1 pickup.
AH2-7	AXIS HUMBUCKER 2-7	B	H	C	Seven-string version of AH2 pickup.
AHS1	AXIS SINGLE 1	N	S	AL	Traditional sounding single coil pickup with increased output for neck position.
AHS2	AXIS SINGLE 2	M	A	AL	Traditional sounding single coil pickup with increased output for center position.
CCR1	CCR1	N	H	AL	Moderate output. Alnico 8 magnet contributes crispy edge with bright high.
CCR2	CCR2	B	H	AL	Moderate output. Alnico 8 magnet contributes crispy edge with bright high.
GB SPECIAL	GB SPECIAL	B	H	AL	Floating pickup co-designed by George Benson for hollow bodies at higher volumes. Warm, well rounded output with less feedback.
GB SPECIAL	GB SPECIAL	N	H	AL	Neck version of above.
HFS1	HFS1	N	S	C	Single coil's brightness without the susceptibility to hum noise.
HFS2	HFS2	B	S	C	Single coil's brightness without the susceptibility to hum noise.
HGD1	Hot Grinder 1	N	H	AL	Hot, but sharp enough to hear pick bites the strings.
HGD2	Hot Grinder 2	B	H	C	Hot, but sharp enough to hear pick bites the strings.
INF1	INFINITY 1	N	H	C	Versatile and responsive with warm classic tone and added output.
INF2	INFINITY 2	B	H	AL	Enhanced midrange output. Alnico-5 magnet for individual string clarity. Excellent dynamics.
INF3	INFINITY 3	N	H	C	Provides the dynamic sound for chording and rhythm.
INF4	INFINITY 4	B	H	C	Brilliant lead pickup. Warm sounding with good harmonics.
INFS1	INFINITY SINGLE 1	M	S	AL	Warm single coil tone with added output.
INFS3	INFINITY SINGLE 3	M	S	C	Traditional sounding yet high output. Designed to work with humbuckers in the split position.
LZ1-N	LoZ-N	N	H	C	High output yet low noise, active pickup operated by AA Batteries (3 volts)
LZ1-B	LoZ-B	B	H	C	High output yet low noise, active pickup operated by AA Batteries (3 volts)
LZ3-N	LoZ-N	N	H	C	Active Pickup. High-output fat sound, yet tweaked to produce a balanced clean sound.
LZ3-B	LoZ-B	B	H	C	Active Pickup. High-output fat sound, yet tweaked to produce a balanced clean sound.
LZ4-N	LoZ-N	N	H	AL	Active Pickup. Wide dynamic range from fat & heavy to bright & loud.
LZ4-B	LoZ-B	B	H	C	Active Pickup. Wide dynamic range from fat & heavy to bright & loud.
LZ7-N	LoZ-N	N	H	C	Seven-string version of LZ3 pickup.
LZ7-B	LoZ-B	B	H	C	Seven-string version of LZ3 pickup.
LZ8-N	LoZ-N	N	H	C	Eight-string version of LZ3 pickup.

LZ8-B	LoZ-B	B	H	C	Eight-string version of LZ3 pickup.
PP1-N	PP1-N	N	H	AL	Tube construction of the pole-piece provides quick response, clarity and added harmonics.
PP1-B	PP1-B	B	H	C	Tube construction of the pole-piece provides quick response, clarity and added harmonics.
PSNDS	PSNDS	M/N	S	AL	High output with complete clarity.
PSND1	PSND1	N	H	C	High output in the neck position with no "muddiness."
PSND2	PSND2	B	H	C	High output with enhanced harmonics.
PSND3	PSND3	N	H	AL	High-output with plenty of clarity.
PSND4	PSND4	B	H	C	High-output works for both lead and rhythm.
S1	SINGLE 1	M/N	S	AL	Traditional sounding, but high output single coil with Alnico-5 polepieces for even string output. Designed to work with humbuckers in the split position.
S58	SUPER 58	A11	H	AL	Classic, warm and versatile. Handles both jazz and rock without feedback.
S58C	SUPER 58 Custom	A11	H	AL	Classic, warm and versatile.
SL58	SILENT 58	A11	H	AL	Classic, warm and versatile. Handles both jazz and rock without feedback.
ST2	Short Tracer	M	S	AL	Alnico magnet provides full output in low profile setting.
STDH1	STANDARD 1	N	H	C	Clean with a smooth midrange.
STDH2	STANDARD 2	B	H	C	Bridge version of STDH1.
TDB1	True-Duo Bucker	B/N	H	C/AL	Designed for switching between genuine double and single-coil sound in one pickup.
TDB2	True-Duo Blast 1	N	H	C/AL	Same True-Duo construction as True-Duo Bucker, but the wiring enables True-Duo function as a pair, Bridge and Neck.
TDB3	True-Duo Blast 2	B	H	C/AL	Same True-Duo construction as True-Duo Bucker, but the wiring enables True-Duo function as a pair, Bridge and Neck.
V7	V7	N	H	C	Tight, but bright. Very dynamic for chording and rhythm.
V7C	V7 Custom	N	H	AL	Smooth and dynamic tone with warm mid-range.
V8	V8	B	H	AL	Warm yet articulate lead pickup with enhanced overtones. Good harmonics without excessive brightness.
V8C	V8 Custom	B	H	C	Rich, harmonic tone with clarity in low-end.
V77	V77	N	H	C	Seven-string version of V7 pickup.
V77C	V77 Custom	N	H	C	Seven-string version of V7C.
V87	V87	B	H	C	Seven-string version of V8 pickup.
V87C	V87 Custom	B	H	C	Seven-string version of V8C.
VK1-DT	VK-Down Tunz	N	H	AL	High output yet clarity in the high end with V bar polepieces.
VK2-DT	VK-Down Tunz	B	H	AL	High output yet clarity in the high end with V bar polepieces.

IBANEZ BASS PICKUPS					
ACHB-2	ACHB-2	B/N	H/P	C	High output humbucking pickup.
ADX5	ACTIVE DYNAMIX 5	B/N	H/A	C	Quiet, dynamic, punchy sound on all 5 strings. Two different sized bobbins provide even string output. Individually calibrated for neck and bridge positions.
ATK	ATK TRIPLE COIL	B	H/P	C	Heavy bottom and natural high end.
DXH-5	DYNAMIX-5	B/N	H/P	C	Powerful with good midrange punch.
DXH-6	DYNAMIX-6	B/N	H/P	C	Six-string version of DXH-5.
EXF-4	EX FULL RANGE 4	B/N	H/P	C	Balanced tone and sound among each string.
EXF-5	EX FULL RANGE 5	B/N	H/P	C	5-string version of EXF-4.
PFR-4	PASSIVE FULL RANGE	B/N	H/P	C	Powerful full range pickup with added low mids.
PFR-5	PASSIVE FULL RANGE	B/N	H/P	C	Powerful full range pickup with added low mids.
PFR-AL4	PASSIVE FULL RANGE	B/N	H/P	AL	Powerful Alnico magnet pickup with exceptional clarity and very even response.
PFR-AL5	PASSIVE FULL RANGE	B/N	H/P	AL	5-string version of PFR-AL4.
PPD4	POWERPOLE DUAL COIL	B/N	H/P	C	Passive bass sound with plenty of punch.
PPD5	POWERPOLE DUAL COIL	B/N	H/P	C	Five-string version of PPD4.
PSNDJ	PSNDJ	B/N	H/P	C	High output with added highs.
PSNDP	PSNDP	B/N	H/P	C	High output with plenty of punch.
SFR-GWB	SONIC FULL RANGE	B/N	H/P	C	Custom wound for GWB35. Quick attack, superior dynamics and added highs.

Frequency Response Curves

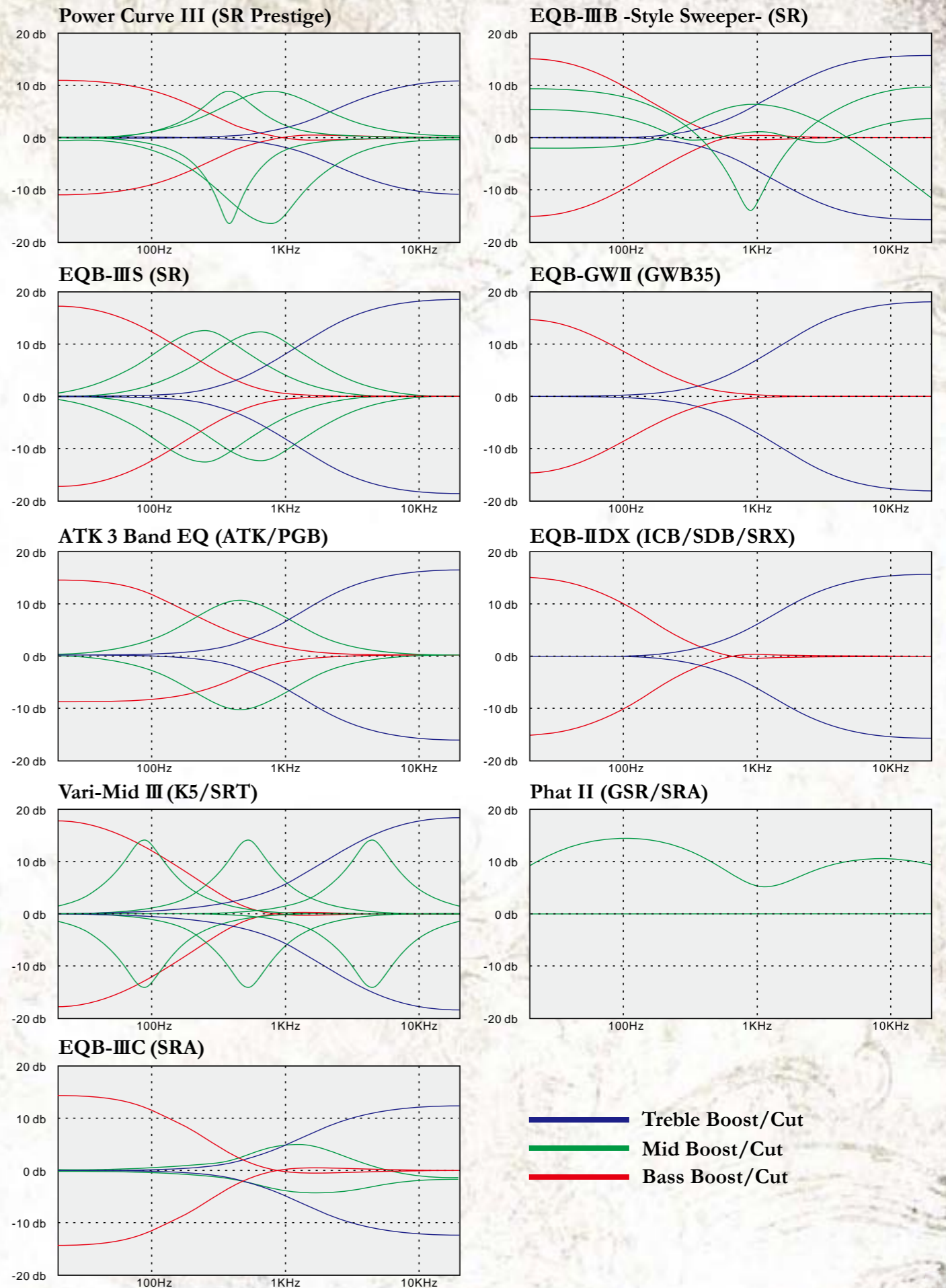

Switching Systems

H-S-H (5WAY) RG (HSH), JEM, UV, NDM, S (HSH), GRG (HSH)

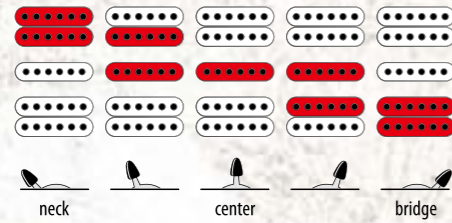

S-S-H (5WAY) GSA

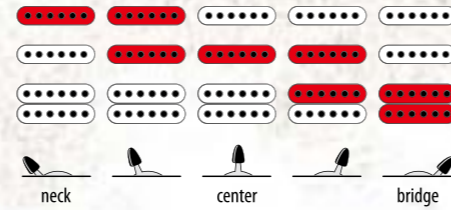

H-S-H (w/True-Duo Blast) SV

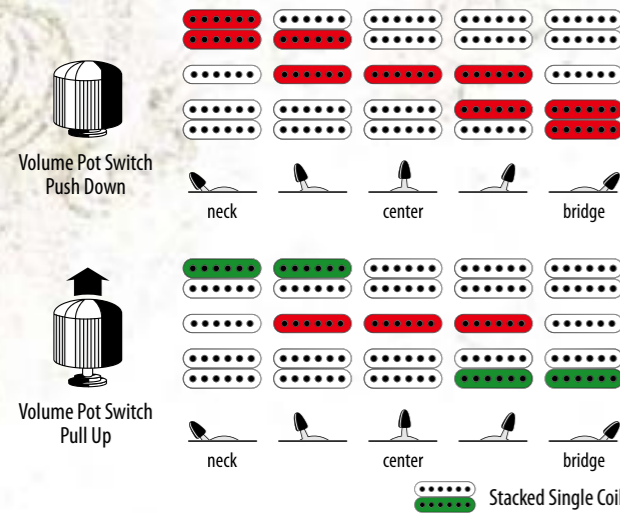

S-S-H (w/True-Duo Bucker) SA (SSH)

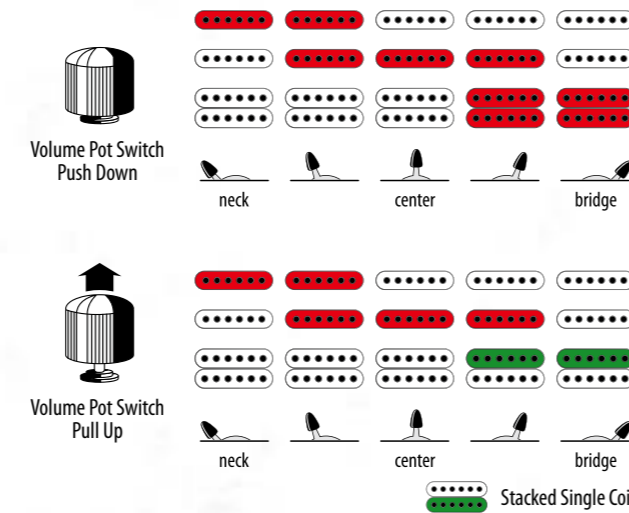

H-S-H (5WAY) EGEN18, EGEN8

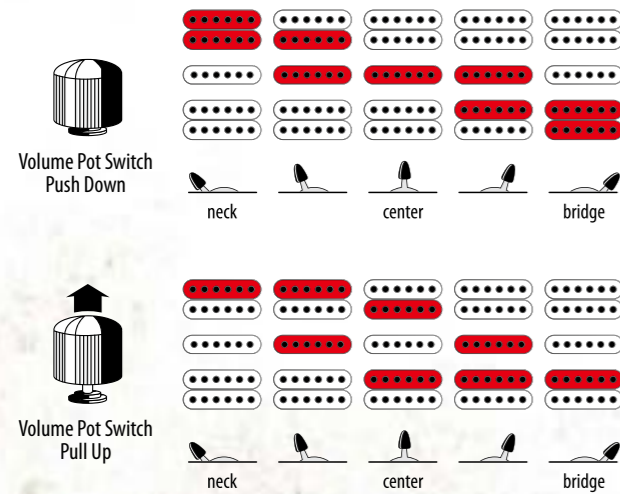

H-H (3WAY) JS2400

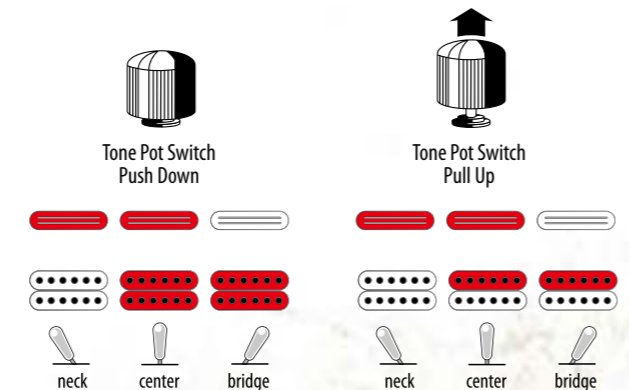

H-H-H (5WAY) AT100CL

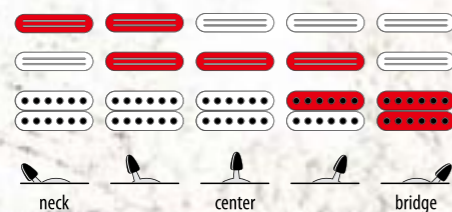

H-H (3WAY) DN500K, JS1600, JS1200, JS1000, JS100

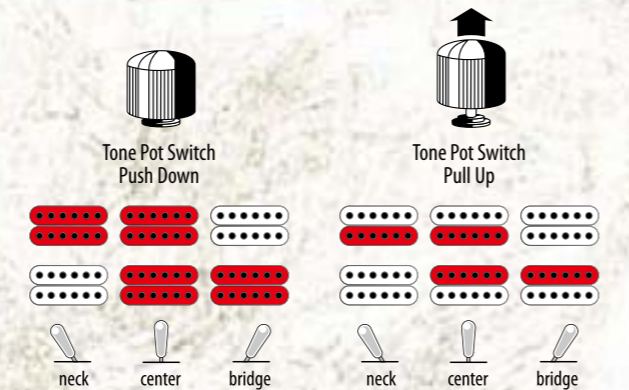

H-H (5WAY) RG (HH), RGD320, S (HH), SA (HH), XP300

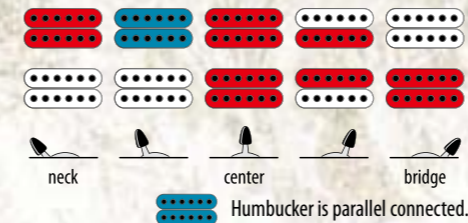

H-H (5WAY) FR

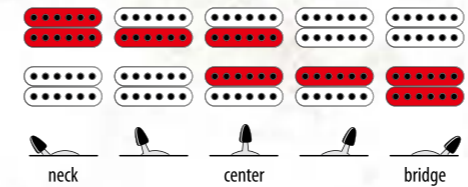

H-H (5WAY) PGM

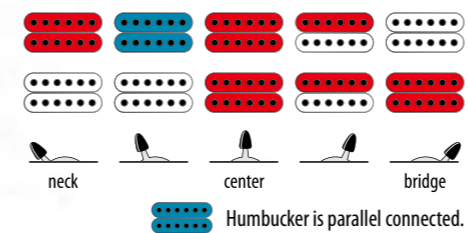

H-H (3WAY) AR, ART, ARTCORE, APEX, ARX, DTT, GART, GAX, GB (HH), GRG (HH), GRGA, GRGM, JSM, JTK40, MBM, MTM, PM120, RG (w/EMG), RGA, RGD Prestige, XP300FX, XPT (HH), ICT, STM

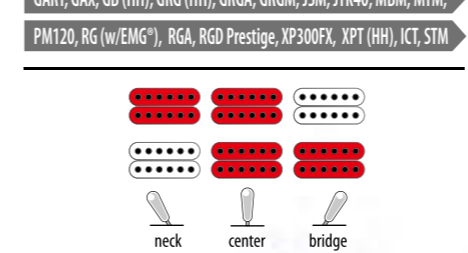

H-H (3WAY) XPT700XH

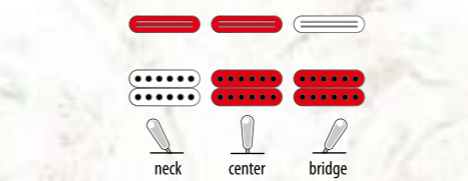

S-S (3WAY) JTK30

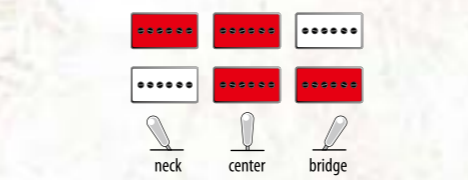

H (2WAY) GB15

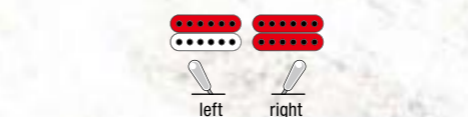

Neck Dimensions

NECK MODEL	SCALE LENGTH	WIDTH AT NUT	WIDTH AT LAST FRET	THICKNESS AT 1ST FRET	THICKNESS AT 12TH FRET	RADIUS
GUITAR NECK DIMENSIONS						
APEX	648mm/25.5"	48mm	68mm	19mm	21mm	430mmR
APEX2	648mm/25.5"	48mm	68mm	19mm	21mm	305mmR
AR	628mm/24.75"	43mm	57mm	20mm	22mm	305mmR
ARTCORE	628mm/24.75"	43mm	57mm	20mm	22mm (at 9F)	305mmR
ARX/ART	628mm/24.75"	43mm	57mm	20mm	22mm	305mmR
AT	648mm/25.5"	40.5mm	57mm	21mm	23mm	305mmR
DN	628mm/24.75"	43mm	57mm	20mm	22.5mm	305mmR
EGEN	648mm/25.5"	43mm	58mm	18mm	20mm	430mmR
GB	628mm/24.75"	43mm	57mm	20mm	23mm	305mmR
GB15	628mm/24.75"	44mm	58mm	20mm	23mm	305mmR
GRG1	648mm/25.5"	43mm	58mm	19.5mm	21.5mm	400mmR
GRGA	648mm/25.5"	42mm	56mm (at 21 F)	20.5mm	23mm	400mmR
GRGM	560mm/22"	42mm	56mm	20.5mm	23mm	400mmR
GRX	648mm/25.5"	42mm	56mm	20mm	22mm	350mmR
GSA	648mm/25.5"	43mm	57mm	19.5mm	21.5mm	400mmR
JEM	648mm/25.5"	43mm	58mm	18mm	20mm	430mmR
JS	648mm/25.5"	42mm	58mm	20mm	22.3mm	250mmR
JS100	648mm/25.5"	42mm	57mm	20mm	22mm	400mmR
JSM	628mm/24.75"	43.5mm	57mm	20.2mm	23mm	COMPOUND
JTK	648mm/25.5"	43mm	56mm	21.5mm	23mm	305mmR
MBM	648mm/25.5"	43mm	58mm	18mm	20mm	430mmR
NDM	648mm/25.5"	42mm	57mm	20mm	22mm	240mmR
ORM	610mm/24.0"	43mm	57mm	20.5mm	23mm	305mmR
PGM	648mm/25.5"	43mm	58mm	18mm	20mm	430mmR
PM35	628mm/24.75"	43mm	57mm	20mm	22mm (at 9F)	305mmR
SA/SAS	648mm/25.5"	43mm	56mm (at 21 F)	20.5mm	23mm	400mmR
SA120	648mm/25.5"	43mm	57mm	19.5mm	21mm	400mmR
SUPER WIZARD HP	648mm/25.5"	43mm	58mm	17mm	19mm	430mmR
ULTRA HP	648mm/25.5"	43mm	58mm	18mm	20mm	430mmR
ULTRA-8	685.8mm/27"	54mm	78mm	20mm	21.5mm	430mmR
UV	648mm/25.5"	48mm	68mm	19mm	21mm	430mmR
WIZARD HP	648mm/25.5"	43mm	58mm	18mm	20mm	430mmR
WIZARD HP (RGD2120Z)	672mm/26.5"	43mm	58mm	18mm	20mm	430mmR
WIZARD II	648mm/25.5"	43mm	58mm	19mm	21mm	400mmR
WIZARD II (RGD)	672mm/26.5"	43mm	58mm	19mm	21mm	400mmR
WIZARD II-7	648mm/25.5"	48mm	68mm	19mm	21mm	400mmR
WIZARD II-8	685.8mm/27"	55mm	80mm	20mm	21.5mm	400mmR
WIZARD-7	648mm/25.5"	48mm	68mm	19mm	21mm	430mmR
WIZARD-7 (RGD2127Z)	672mm/26.5"	48mm	68mm	19mm	21mm	400mmR
BASS NECK DIMENSIONS						
ARTB4	770mm/30.3"	42mm	63mm	21.5mm	24.5mm	305mmR
ARTCORE	770mm/30.3"	42mm	63mm	21.5mm	24.5mm	305mmR
ATK4	864mm/34"	42.5mm	63mm	21mm	24mm	305mmR
ATLAS-4 HP	864mm/34"	38mm	60mm	19.5mm	22.5mm	305mmR
ATLAS-5 HP	864mm/34"	45mm	67mm	19.5mm	23mm	305mmR
ATLAS-6 HP	864mm/34"	54mm	83mm	19.5mm	23mm	500mmR
BTB5	889mm/35"	47mm	76mm	20mm	22mm	400mmR
BTB6	889mm/35"	54mm	88mm	20mm	22mm	400mmR
GSR4	864mm/34"	41mm	62mm	21mm	22mm	305mmR
GSR5	864mm/34"	45mm	67mm	21mm	22mm	305mmR
GSR6	864mm/34"	54mm	84mm	21mm	22mm	400mmR
GSRM	726.2mm/28.6"	38mm	58.5mm	21mm	22mm (at 12F)	305mmR
GWB1005	864mm/34"	45mm	67mm	19mm	21mm	305mmR
GWB35	864mm/34"	45mm	67mm	19mm	21mm	305mmR
ICB4	864mm/34"	40mm	64mm	20mm	23mm	400mmR
JTKB	864mm/34"	40mm	64mm	20mm	23mm	400mmR
K5	864mm/34"	45mm	67mm	19.5mm	21.5mm	305mmR
MDB4	864mm/34"	38mm	62mm	21mm	23mm	305mmR
PGB4	864mm/34"	42.5mm	63mm	21mm	24mm	240mmR
PIB5	864mm/34"	45mm	67mm	21.5mm	23.5mm	305mmR
PRB4	864mm/34"	38mm	62mm	20.5mm	23mm	305mmR
SDB4	864mm/34"	43mm	60mm	22.5mm	22.5mm	305mmR
SR4	864mm/34"	38mm	62mm	19.5mm	21.5mm	305mmR
SR5	864mm/34"	45mm	67mm	19.5mm	21.5mm	305mmR
SR6	864mm/34"	54mm	83mm	19.5mm	21.5mm	400mmR
SRA4	864mm/34"	38mm	62mm	21mm	23mm	400mmR
SRA5	864mm/34"	45mm	67mm	21mm	23mm	400mmR
SRT4	864mm/34"	38mm	62mm	21.5mm	23.5mm	305mmR
SRT5	864mm/34"	45mm	67mm	21.5mm	23.5mm	305mmR
SRX4	864mm/34"	38mm	62mm	21mm	23mm	305mmR
SRX5	864mm/34"	45mm	73mm	21mm	23mm	400mmR

Edge-Zero Tremolo



The Edge-Zero has a sharp knife-edge for extremely accurate tremolo playing. This tremolo also uses Ibanez innovations to keep string action constant and the bridge surface smooth. The specially designed arm socket prevents unnecessary wobble from the arm while providing full control over the arm's torque.

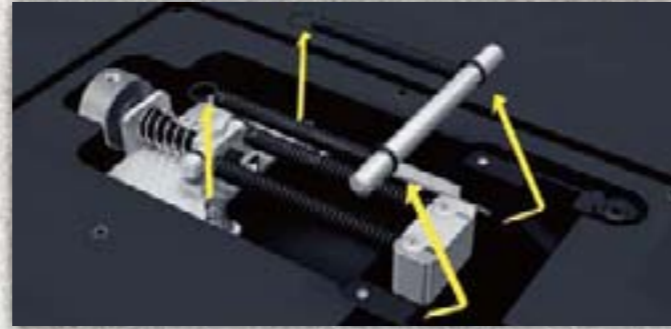
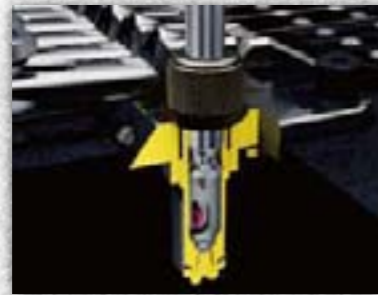

ZPS3 Zero Point System

The ZPS3 is the next stage of zero point systems. Made of lightweight Duralumin, the addition of two outer springs makes the guitar easier to tune and provides much greater tuning stability. In fact, the other strings will stay in tune even if you break a string. If you prefer a full floating tremolo setup, simply remove the stop bar.



Spring Mute

Some might think it's inevitable for tremolo springs to resonate, but that's not the case with the Ibanez Prestige. The spring-muting rubber eliminates noise from the spring, providing only clean and cutting sound.

ZR-2 Tremolo



The ZR-2 is a revolutionary tremolo system. It plays incredibly smooth through the use of its ball bearing mechanism. This also keeps the string action constant, even during the most rigorous tremolo use. The top side features a smooth finish for total hand comfort, and the tremolo arm snaps in for quick setup.

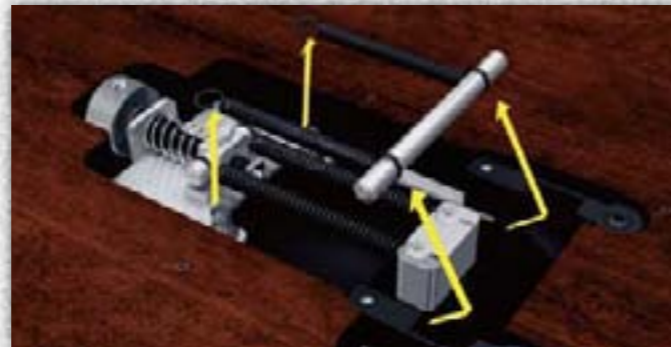

ZPS3 Zero Point System

The ZPS3 is the next stage of zero point systems. Made of lightweight Duralumin, the addition of two outer springs makes the guitar easier to tune and provides much greater tuning stability. In fact, the other strings will stay in tune even if you break a string. If you prefer a full floating tremolo setup, simply remove the stop bar.



SynchroniZR Tremolo



The SynchroniZR provides all the innovations of the ZR tremolo in a non-locking design. The one-piece saddle construction minimizes unnecessary wobble and loss of string vibration, and the ultra-light Duralumin tremolo arm keeps the bridge stable while playing. The same intonation and adjustment features of the ZR-2 make this a top-notch choice for any kind of player.



ZPS-FX System

The ZPS-FX is the simplified alternative to the ZPS3 system. This spring system allows switching from floating to non-floating tremolos with the turn of a knob on the back. Coupled with the SynchroniZR, the ZPS-FX offers total sonic control and the pinnacle of tuning stability.



Tight-Tune Bridge/Tailpiece



Solid as a rock, the Tight-Tune bridge and tailpiece were designed to lock down securely and prevent any kind of wobble or movement. Each saddle is locked into the base plate, and the bridge is anchored by stud bolts into the body of the guitar. Furthermore, the studs are also locked onto the base plate so that the maximum vibration from the string is transferred to the body.

Tight-End Bridge

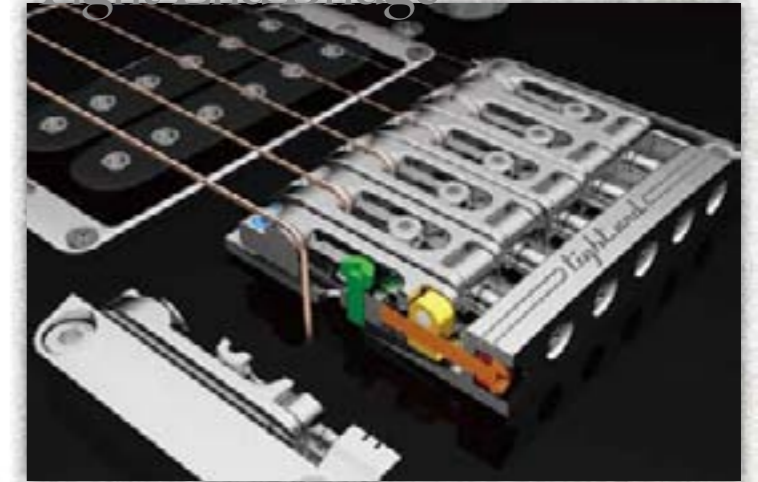

The Tight-End bridge integrates every aspect of the bridge design in rigidity and accuracy. Saddles are firmly locked onto the base plate for maximum string vibration, and remain perfectly linear during intonation adjustment for the most accurate set up. The saddle height can be adjusted individually by one screw. Also, the top side of the bridge is smooth finished. So if you play hard, the Tight-End bridge will forgive you and your hands.

MR4 Mono-Rail Bridge



The Mono-Rail Bridge is the ultimate in string isolation for bass. Each saddle is independently and securely locked down to the body for maximum vibration transfer and no interference. One screw controls the height of each saddle for easy adjustment.

Finishes

